

WARNING

Servicing a vehicle can be dangerous. If you have not received service-related training, the risks of injury, property damage, and failure of servicing increase. The recommended servicing procedures for the vehicle in this workshop manual were developed with Mazda-trained technicians in mind. This manual may be useful to non-Mazda trained technicians, but a technician with our service-related training and experience will be at less risk when performing service operations. However, all users of this manual are expected to at least know general safety procedures.

This manual contains "Warnings" and "Cautions" applicable to risks not normally encountered in a general technician's experience. They should be followed to reduce the risk of injury and the risk that improper service or repair may damage the vehicle or render it unsafe. It is also important to understand that the "Warnings" and "Cautions" are not exhaustive. It is impossible to warn of all the hazardous consequences that might result from failure to follow the procedures.

The procedures recommended and described in this manual are effective methods of performing service and repair. Some require tools specifically designed for a specific purpose. Persons using procedures and tools which are not recommended by Mazda Motor Corporation must satisfy themselves thoroughly that neither personal safety nor safety of the vehicle will be jeopardized.

The contents of this manual, including drawings and specifications, are the latest available at the time of printing, and Mazda Motor Corporation reserves the right to change the vehicle designs and alter the contents of this manual without notice and without incurring obligation.

Parts should be replaced with genuine Mazda replacement parts or with parts which match the quality of genuine Mazda replacement parts. Persons using replacement parts of lesser quality than that of genuine Mazda replacement parts must satisfy themselves thoroughly that neither personal safety nor safety of the vehicle will be jeopardized.

Mazda Motor Corporation is not responsible for any problems which may arise from the use of this manual. The cause of such problems includes but is not limited to insufficient service-related training, use of improper tools, use of replacement parts of lesser quality than that of genuine Mazda replacement parts, or not being aware of any revision of this manual.

Automatic Transaxle Workshop Manual FW6A-EL

FOREWORD

This manual explains the service points for the above-indicated automotive system. This manual covers all models with the above-indicated automotive system, not any one specific model.

In order to do these procedures safely, quickly, and correctly, you must first read this manual and any other relevant service materials carefully.

All the contents of this manual, including drawings and specifications, are the latest available at the time of printing. As modifications affecting repair or maintenance occur, relevant information supplementary to this volume will be made available at Mazda dealers. This manual should be kept up-to-date.

Mazda Motor Corporation reserves the right to alter the specifications and contents of this manual without obligation or advance notice.

All rights reserved. No part of this book may be reproduced or used in any form or by any means, electronic or mechanical—including photocopying and recording and the use of any kind of information storage and retrieval system—without permission in writing.

**Mazda Motor Corporation
HIROSHIMA, JAPAN**

CONTENTS

Title	Section
GENERAL INFORMATION	00
TRANSMISSION/TRANSAXLE	05

© 2012 Mazda Motor Corporation
PRINTED IN U.S.A., JANUARY 2012
Form No. 1A10-1U-12A
Part No. 9999-95-FW6A-12

GENERAL INFORMATION

00
SECTION

00-00

GENERAL INFORMATION 00-00

00-00 GENERAL INFORMATION

HOW TO USE THIS MANUAL	00-00-2	Measuring Equipment	00-00-6
Range of Topics	00-00-2	Special Service Tools	00-00-6
Service Procedure	00-00-2	Disassembly	00-00-6
Symbols	00-00-4	Inspection During Removal,	
Advisory Messages	00-00-4	Disassembly	00-00-6
UNITS	00-00-5	Arrangement of Parts	00-00-7
Conversion From SI Units		Cleaning of Parts	00-00-7
(Système International d'Unités)	00-00-5	Reassembly	00-00-7
Number Of Digits For		Adjustment	00-00-8
Converted Values	00-00-5	Rubber Parts and Tubing	00-00-8
Converted Value Rounding Off And		Torque Formulas	00-00-8
Rounding Up/down	00-00-5	Vise	00-00-8
FUNDAMENTAL PROCEDURES	00-00-6	ABBREVIATIONS	00-00-9
Preparation of Tools and			

GENERAL INFORMATION

HOW TO USE THIS MANUAL

id000000000100

Range of Topics

- This manual contains procedures for performing all required service operations. The procedures are divided into the following basic operations:
 - Removal/Installation
 - Disassembly/Assembly
 - Replacement
 - Inspection
 - Adjustment
- Simple operations which can be performed easily just by looking at the actual unit (i.e., removal/installation of parts, cleaning of parts, and visual inspection) have been omitted.

Service Procedure

Inspection, adjustment

- Inspection and adjustment procedures are divided into steps. Important points regarding the location and contents of the procedures are explained in detail and shown in the illustrations.

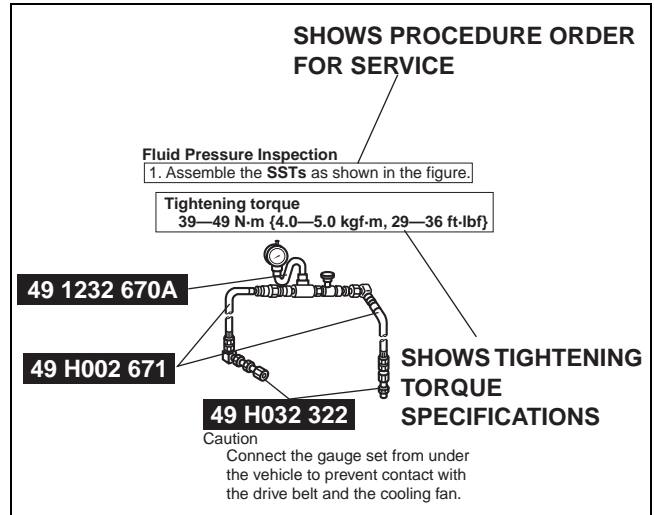

bpe2ue00000101

GENERAL INFORMATION

00-00

Repair procedure

1. Most repair operations begin with an overview illustration. It identifies the components, shows how the parts fit together, and describes visual part inspection. However, only removal/installation procedures that need to be performed methodically have written instructions.
2. Expendable parts, tightening torques, and symbols for oil, grease, and sealant are shown in the overview illustration. In addition, symbols indicating parts requiring the use of special service tools or equivalent are also shown.
3. Procedure steps are numbered and the part that is the main point of that procedure is shown in the illustration with the corresponding number. Occasionally, there are important points or additional information concerning a procedure. Refer to this information when servicing the related part.

Procedure

"Removal/Installation" Portion

"Inspection After Installation" Portion

INSTALL THE PARTS BY PERFORMING STEPS 1—3 IN REVERSE ORDER

SHOWS SERVICE ITEM (S)

INDICATES ANY RELEVANT REFERENCES WHICH NEED TO BE FOLLOWED DURING INSTALLATION

SHOWS SPECIAL SERVICE TOOL (SST) FOR SERVICE OPERATION

SHOWS APPLICATION POINTS OF GREASE, ETC.

SHOWS NON-REUSEABLE PARTS

SHOWS DETAILS

SHOWS TIGHTENING TORQUE UNITS

SHOWS THERE ARE REFERRAL NOTES FOR SERVICE

SHOWS TIGHTENING TORQUE SPECIFICATIONS

SHOWS PROCEDURE ORDER FOR SERVICE

SHOWS TIGHTENING TORQUE UNITS

LOWER TRAILING LINK, UPPER TRAILING LINK REMOVAL/INSTALLATION

1. Jack up the rear of the vehicle and support it with safety stands.
2. Remove the undercover. (See 01-10-4 Undercover Removal)
3. Remove in the order indicated in the table.
4. Install in the reverse order of removal.
5. Inspect the rear wheel alignment and adjust it if necessary.

1	Split pin
2	Nut
3	Lower trailing link ball joint (See 02-14-5 Lower Trailing Link Ball Joint Removal Note)
4	Bolt
5	Lower trailing link
6	Dust boot (lower trailing link)

7	Split pin
8	Nut
9	Upper trailing link ball joint (See 02-14-5 Upper Trailing Link Ball Joint Removal Note)
10	Nut
11	Upper trailing link
12	Dust boot (upper trailing link)

Lower Trailing Link Ball Joint, Upper Trailing Link Ball Joint Removal Note

- Remove the ball joint using the SSTs.









SHOWS SPECIAL SERVICE TOOL (SST) NO.

bpe2ue0000001

GENERAL INFORMATION

Symbols

- There are eight symbols indicating oil, grease, fluids, sealant, and the use of **SST** or equivalent. These symbols show application points or use of these materials during service.

Symbol	Meaning	Kind
	Apply oil	New appropriate engine oil or gear oil
	Apply brake fluid	New appropriate brake fluid
	Apply automatic transaxle/ transmission fluid	New appropriate automatic transaxle/ transmission fluid
	Apply grease	Appropriate grease
	Apply sealant	Appropriate sealant
	Apply petroleum jelly	Appropriate petroleum jelly
	Replace part	O-ring, gasket, etc.
	Use SST or equivalent	Appropriate tools

Advisory Messages

- You will find several **Warnings, Cautions, Notes, Specifications** and **Upper and Lower Limits** in this manual.

Warning

- A Warning indicates a situation in which serious injury or death could result if the warning is ignored.

Caution

- A Caution indicates a situation in which damage to the vehicle or parts could result if the caution is ignored.

Note

- A Note provides added information that will help you to complete a particular procedure.

Specification

- The values indicate the allowable range when performing inspections or adjustments.

Upper and lower limits

- The values indicate the upper and lower limits that must not be exceeded when performing inspections or adjustments.

GENERAL INFORMATION

UNITS

id000000100400

Electric current	A (ampere)
Electric power	W (watt)
Electric resistance	ohm
Electric voltage	V (volt)
Length	mm (millimeter)
	in (inch)
Negative pressure	kPa (kilo pascal)
	mmHg (millimeters of mercury)
	inHg (inches of mercury)
Positive pressure	kPa (kilo pascal)
	kgf/cm ² (kilogram force per square centimeter)
	psi (pounds per square inch)
Number of revolutions	rpm (revolutions per minute)
Torque	N·m (Newton meter)
	kgf·m (kilogram force meter)
	kgf·cm (kilogram force centimeter)
	ft·lbf (foot pound force)
	in·lbf (inch pound force)
Volume	L (liter)
	US qt (U.S. quart)
	Imp qt (Imperial quart)
	ml (milliliter)
	cc (cubic centimeter)
	cu in (cubic inch)
	fl oz (fluid ounce)
Weight	g (gram)
	oz (ounce)

00-00

Conversion From SI Units (Système International d'Unités)

- All numerical values in this manual are based on SI units. Numbers shown in conventional units are converted from these values.

Number Of Digits For Converted Values

- The number digits for converted values is the same as the number of significant figures*¹ of the SI unit.
- For the torque value, the number of significant figures is, in principle, is 2 digits, in consideration of market practicalities. However, if the number of decimal places at the upper and lower limits of the converted value differs, the one with least number of decimal places is used. In addition, if the integer part is 3 digits or more, the integer part becomes the significant number of figures.

*1 : The number of significant figures is the number of digits from the left-most non-zero digit to the right-most digit including 0. (Example: 0.12 is 2 digits, 41.0 is 3 digits)

Converted Value Rounding Off And Rounding Up/down

- If there is no tolerance in the SI unit value, after conversion, rounding off is to within the number of significant digits.
- If there is tolerance in the SI unit value and the figure after conversion indicates the upper limit, the number of digits is rounded down to within the number of significant figures. If it indicates the lower limit, they are rounded up to within the number of significant figures.
- Even if the SI unit value is the same, the converted value may differ based on whether that value is the upper or lower limit.

GENERAL INFORMATION

FUNDAMENTAL PROCEDURES

id000000750100

Preparation of Tools and Measuring Equipment

- Be sure that all necessary tools and measuring equipment are available before starting any work.

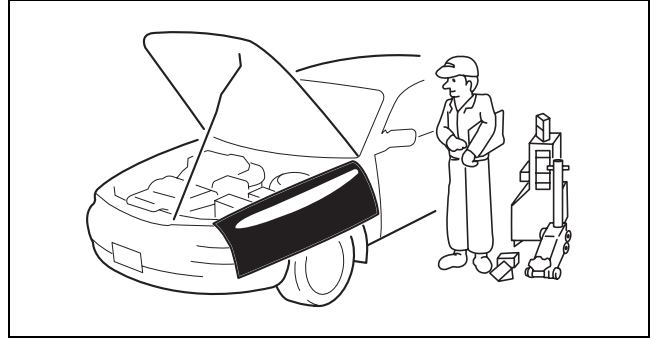

bpe2ue00000110

Special Service Tools

- Use special service tools or equivalent when they are required.

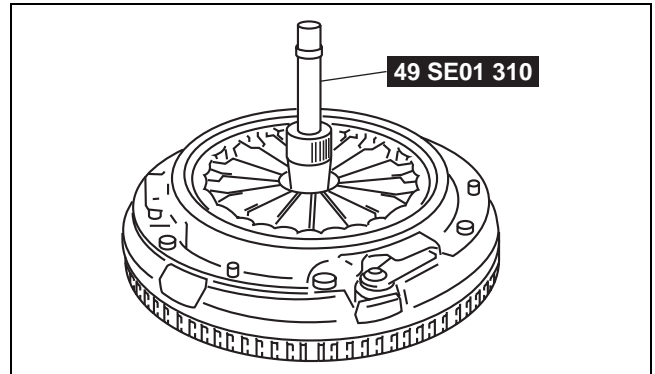

bpe2ue00000111

Disassembly

- If the disassembly procedure is complex, requiring many parts to be disassembled, all parts should be marked in a place that will not affect their performance or external appearance and identified so that reassembly can be performed easily and efficiently.

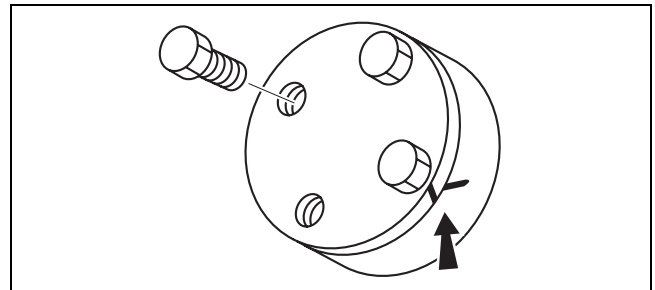

bpe2ue00000112

Inspection During Removal, Disassembly

- When removed, each part should be carefully inspected for malfunction, deformation, damage and other problems.

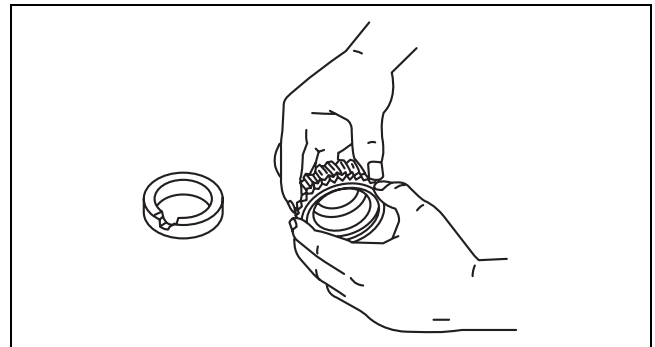

bpe2ue00000113

GENERAL INFORMATION

Arrangement of Parts

- All disassembled parts should be carefully arranged for reassembly.
- Be sure to separate or otherwise identify the parts to be replaced from those that will be reused.

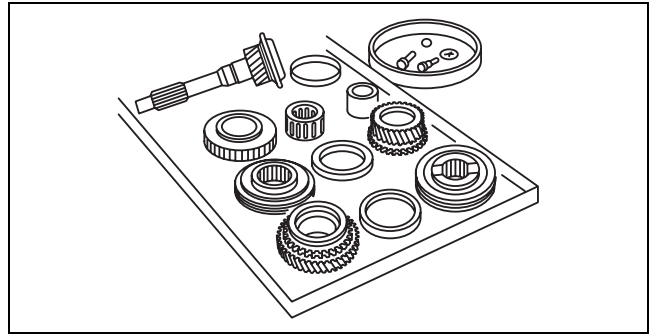

bpe2ue00000114

00-00

Cleaning of Parts

- All parts to be reused should be carefully and thoroughly cleaned in the appropriate method.

Warning

- **Using compressed air can cause dirt and other particles to fly out causing injury to the eyes. Wear protective eye wear whenever using compressed air.**

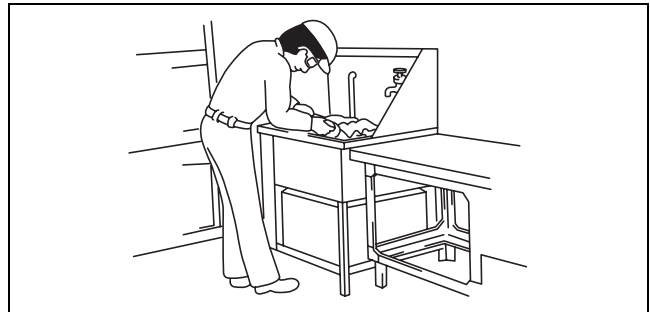

bpe2ue00000002

Reassembly

- Standard values, such as torques and certain adjustments, must be strictly observed in the reassembly of all parts.
- If removed, the following parts should be replaced with new ones:
 - Oil seals
 - Gaskets
 - O-rings
 - Lockwashers
 - Cotter pins
 - Nylon nuts
- Depending on location:
 - Sealant and gaskets, or both, should be applied to specified locations. When sealant is applied, parts should be installed before sealant hardens to prevent leakage.
 - Oil should be applied to the moving components of parts.
 - Specified oil or grease should be applied at the prescribed locations (such as oil seals) before reassembly.

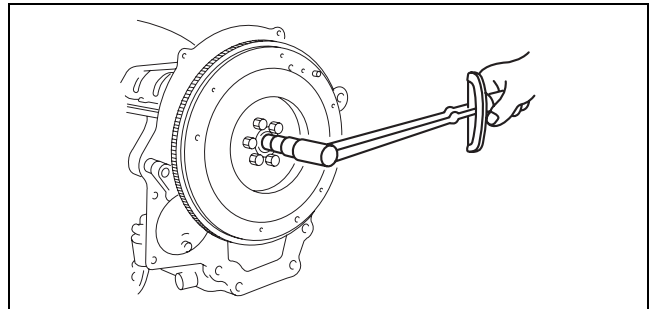

bpe2ue00000115

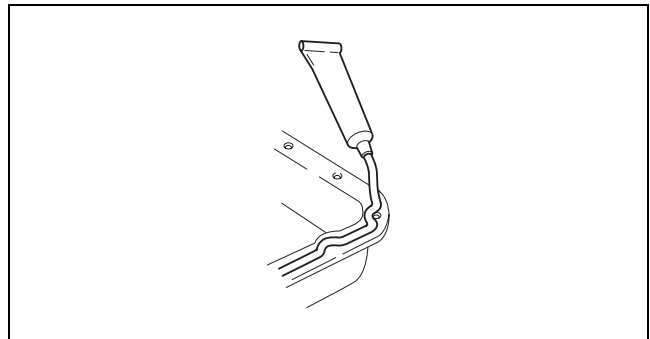

bpe2ue00000116

GENERAL INFORMATION

Adjustment

- Use suitable gauges and testers when making adjustments.

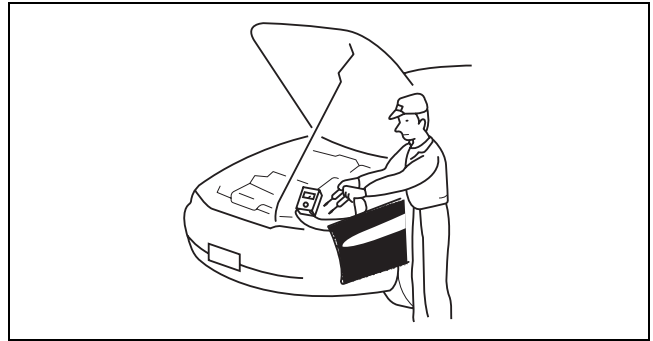

bpe2ue00000117

Rubber Parts and Tubing

- Prevent gasoline or oil from getting on rubber parts or tubing.

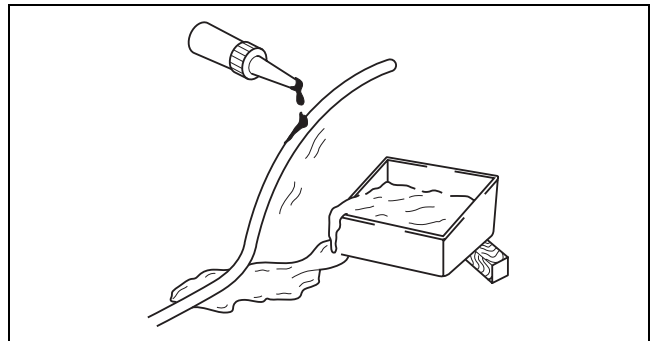

bpe2ue00000118

Torque Formulas

- When using a torque wrench-**SST** or equivalent combination, the written torque must be recalculated due to the extra length that the **SST** or equivalent adds to the torque wrench. Recalculate the torque by using the following formulas. Choose the formula that applies to you.

Torque Unit	Formula
N·m	$N \cdot m \times [L / (L + A)]$
kgf·m	$kgf \cdot m \times [L / (L + A)]$
kgf·cm	$kgf \cdot cm \times [L / (L + A)]$
ft·lbf	$ft \cdot lbf \times [L / (L + A)]$
in·lbf	$in \cdot lbf \times [L / (L + A)]$

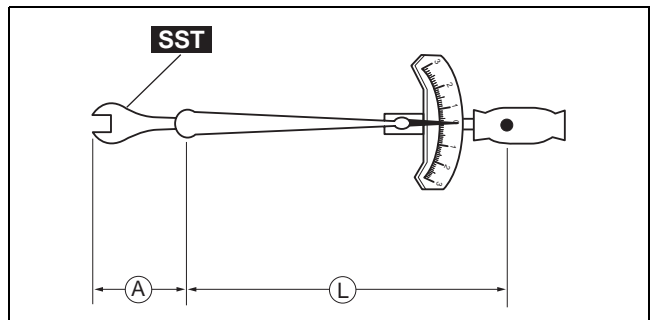

bpe2ue00000119

A : The length of the **SST** past the torque wrench drive.
L : The length of the torque wrench.

Vise

- When using a vise, put protective plates in the jaws of the vise to prevent damage to parts.

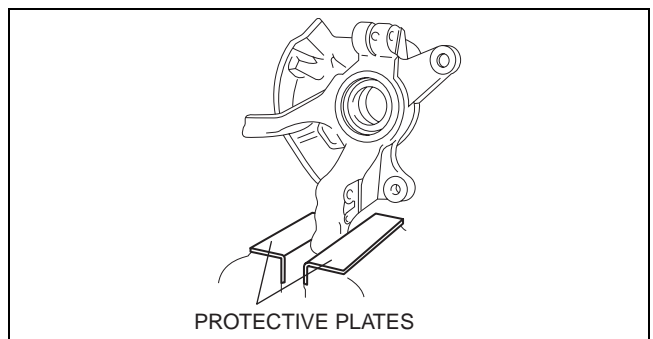

bpe2ue00000120

GENERAL INFORMATION

ABBREVIATIONS

id000000010100

ATF	Automatic Transaxle Fluid
LH	Left Hand
SST	Special Service Tool
TCC	Torque Converter Clutch
TCM	Transaxle Control Module

TRANSMISSION/TRANSAXLE

05
SECTION

05-17

AUTOMATIC TRANSAXLE	05-17	SERVICE TOOLS	05-60
TECHNICAL DATA	05-50		

05-17 AUTOMATIC TRANSAXLE

FOREWORD	05-17-4	RING GEAR AND DIFFERENTIAL	
Operation Cautions	05-17-4	DISASSEMBLY	05-17-121
Required SSTs, Measuring Instruments, and Parts for Servicing	05-17-5	Structural View	05-17-121
After Service Precaution	05-17-6	Disassembly Procedure	05-17-122
AUTOMATIC TRANSAXLE		END COVER COMPONENT	
LOCATION INDEX	05-17-7	DISASSEMBLY	05-17-128
Automatic Transaxle 1	05-17-7	Structural View	05-17-128
Automatic Transaxle 2	05-17-9	Disassembly Procedure	05-17-129
Automatic Transaxle 3	05-17-10	REDUCTION PLANETARY GEAR	
Automatic Transaxle 4	05-17-12	DISASSEMBLY	05-17-136
Automatic Transaxle 5	05-17-14	Structural View	05-17-136
Oil Pump	05-17-16	Disassembly Procedure	05-17-137
Clutch Component	05-17-17	CONTROL VALVE BODY	
Rear Planetary Gear	05-17-18	DISASSEMBLY	05-17-138
Secondary Gear and Output Gear	05-17-19	Structural View	05-17-138
Ring Gear and Differential	05-17-20	Disassembly Procedure	05-17-139
End Cover Component	05-17-22	TORQUE CONVERTER	
Reduction Planetary Gear	05-17-24	CLEANING	05-17-145
Control Valve Body	05-17-25	Cleaning Outside of Torque Converter	05-17-145
AUTOMATIC TRANSAXLE		Torque Converter Flushing	05-17-145
CLEANING	05-17-26	OIL COOLER CLEANING	05-17-147
Cleaning Before Disassembly	05-17-26	Cleaning Outside of Oil Cooler	05-17-147
Cleaning After Disassembly	05-17-27	Oil Cooler Flushing (Water Passage)	05-17-147
Cleaning After Assembly	05-17-28	Oil Cooler Flushing (Oil Passage)	05-17-149
OIL SEAL (OIL PUMP)		VISUAL INSPECTION OF PARTS	05-17-151
REPLACEMENT	05-17-29	TORQUE CONVERTER	
OIL SEAL (PARKING SHIFT LEVER)		INSPECTION	05-17-154
REPLACEMENT	05-17-41	THRUST NEEDLE BEARING	
AUTOMATIC TRANSAXLE		INSPECTION	05-17-155
DISASSEMBLY	05-17-64	FRONT PLANETARY GEAR	
Structural View	05-17-64	INSPECTION	05-17-155
Disassembly Procedure	05-17-70	Radial Needle Bearing Inspection (In Pinion Gear)	05-17-155
CLUTCH COMPONENT		Thrust Needle Bearing Inspection	05-17-156
DISASSEMBLY	05-17-104	Pinion Washer Inspection	05-17-157
Structural View	05-17-104	REAR PLANETARY GEAR	
Disassembly Procedure	05-17-105	INSPECTION	05-17-158
OIL PUMP DISASSEMBLY	05-17-115	Radial Needle Bearing Inspection (In Pinion Gear)	05-17-158
Structural View	05-17-115	Thrust Needle Bearing Inspection	05-17-158
Disassembly Procedure	05-17-115	Pinion Washer Inspection	05-17-160
REAR PLANETARY GEAR		REDUCTION PLANETARY GEAR	
DISASSEMBLY	05-17-117	INSPECTION	05-17-161
Structural View	05-17-117	Radial Needle Bearing Inspection (In Pinion Gear)	05-17-161
Disassembly Procedure	05-17-118	Pinion Washer Inspection	05-17-161
SECONDARY GEAR AND OUTPUT			
GEAR DISASSEMBLY	05-17-119		
Structural View	05-17-119		
Disassembly Procedure	05-17-119		

AUTOMATIC TRANSAXLE

Bush Inner Diameter Inspection 05-17-162	Structural View 05-17-266
SECONDARY GEAR AND OUTPUT	Assembly Procedure 05-17-267
GEAR INSPECTION 05-17-163	END COVER COMPONENT
Taper Roller Bearing Inspection 05-17-163	ASSEMBLY 05-17-273
RING GEAR AND DIFFERENTIAL	Structural View 05-17-273
INSPECTION 05-17-165	Assembly Procedure 05-17-274
Taper Roller Bearing Inspection 05-17-165	CONTROL VALVE BODY
Differential Journal Inspection 05-17-167	ASSEMBLY 05-17-288
Differential Backlash Inspection 05-17-167	Structural View 05-17-288
DRIVE SHAFT JOURNAL	Assembly Procedure 05-17-289
INSPECTION 05-17-168	MEASUREMENT/ADJUSTMENT
LOW CLUTCH INSPECTION 05-17-169	VALUE INPUT SHEET 05-17-295
Drive Plate Inspection 05-17-169	Differential Backlash
HIGH CLUTCH INSPECTION 05-17-169	Measurement/Adjustment 05-17-295
Drive Plate Inspection 05-17-169	High Clutch Clearance
Springs and Retainer Component	Measurement/Adjustment 05-17-296
Inspection 05-17-170	Low Clutch Clearance
Radial Needle Bearing Inspection	Measurement/Adjustment 05-17-297
(In High Clutch Drum Component) . . . 05-17-170	R-3-5 Brake Clearance
LOW AND REVERSE BRAKE	Measurement/Adjustment 05-17-298
INSPECTION 05-17-170	2-6 Brake Clearance
Drive Plate Inspection 05-17-170	Measurement/Adjustment 05-17-299
2-6 BRAKE INSPECTION 05-17-171	Low and Reverse Brake Clearance
Drive plate inspection 05-17-171	Measurement/Adjustment 05-17-300
R-3-5 BRAKE INSPECTION 05-17-171	Secondary Gear and Output Gear
Drive Plate Inspection 05-17-171	Preload Measurement/Adjustment . . . 05-17-301
ONE-WAY CLUTCH INSPECTION 05-17-172	Ring Gear and Differential Preload
LOW CLUTCH HUB INSPECTION 05-17-173	Measurement/Adjustment 05-17-302
Bush Inner Diameter Inspection 05-17-173	Total End Play
HIGH CLUTCH HUB INSPECTION 05-17-173	Measurement/Adjustment 05-17-302
Bush Inner Diameter Inspection 05-17-173	DIFFERENTIAL BACKLASH
OIL PUMP INSPECTION 05-17-174	MEASUREMENT/ADJUSTMENT 05-17-303
Side Clearance Inspection 05-17-174	Preparation Before Servicing 05-17-303
Bush Inner Diameter Inspection	Differential Backlash Measurement . . . 05-17-303
(In Oil Pump Cover) 05-17-176	Differential Backlash Adjustment 05-17-309
Radial Needle Bearing Inspection	HIGH CLUTCH CLEARANCE
(In Oil Pump Housing) 05-17-176	MEASUREMENT/ADJUSTMENT 05-17-317
END COVER INSPECTION 05-17-177	Preparation Before Servicing 05-17-317
Radial Needle Bearing Inspection 05-17-177	High Clutch Clearance
OIL COOLER INSPECTION 05-17-177	Measurement 05-17-317
AUTOMATIC TRANSAXLE	High Clutch Clearance Adjustment . . . 05-17-324
ASSEMBLY 05-17-180	LOW CLUTCH CLEARANCE
Structural View 05-17-180	MEASUREMENT/ADJUSTMENT 05-17-327
Assembly Procedure 05-17-187	Preparation Before Servicing 05-17-327
OIL PUMP ASSEMBLY 05-17-243	Low Clutch Clearance
Structural View 05-17-243	Measurement 05-17-327
Assembly Procedure 05-17-243	Low Clutch Clearance Adjustment 05-17-335
CLUTCH COMPONENT ASSEMBLY . . . 05-17-247	R-3-5 BRAKE CLEARANCE
Structural View 05-17-247	MEASUREMENT/ADJUSTMENT 05-17-339
Assembly Procedure 05-17-248	Preparation Before Servicing 05-17-339
REAR PLANETARY GEAR	R-3-5 Brake Clearance
ASSEMBLY 05-17-259	Measurement/Adjustment 05-17-339
Structural View 05-17-259	2-6 BRAKE CLEARANCE
Assembly Procedure 05-17-260	MEASUREMENT/ADJUSTMENT 05-17-347
REDUCTION PLANETARY GEAR	Preparation Before Servicing 05-17-347
ASSEMBLY 05-17-261	2-6 Brake Clearance Measurement . . . 05-17-347
Structural View 05-17-261	2-6 Brake Clearance Adjustment 05-17-351
Assembly Procedure 05-17-262	LOW AND REVERSE
SECONDARY GEAR AND OUTPUT	BRAKE CLEARANCE
GEAR ASSEMBLY 05-17-263	MEASUREMENT/ADJUSTMENT 05-17-353
Structural View 05-17-263	Preparation Before Servicing 05-17-353
Assembly Procedure 05-17-264	Low and Reverse Brake Clearance
RING GEAR AND DIFFERENTIAL	Measurement 05-17-353
ASSEMBLY 05-17-266	

AUTOMATIC TRANSAXLE

Low and Reverse Brake Clearance Adjustment	05-17-360
SECONDARY GEAR AND OUTPUT GEAR PRELOAD MEASUREMENT/ADJUSTMENT	05-17-364
Preparation Before Servicing	05-17-364
Secondary Gear and Output Gear Preload Measurement	05-17-364
Secondary Gear and Output Gear Preload Adjustment	05-17-372

RING GEAR AND DIFFERENTIAL PRELOAD MEASUREMENT/ADJUSTMENT	05-17-375
Preparation Before Servicing	05-17-375
Ring Gear and Differential Preload Measurement	05-17-375
Ring Gear and Differential Preload Adjustment	05-17-381
TOTAL END PLAY MEASUREMENT/ADJUSTMENT	05-17-385
Preparation Before Servicing	05-17-385
Total End Play Measurement/Adjustment	05-17-385

05-17

AUTOMATIC TRANSAXLE

FOREWORD

id051700660100

Warning

- The engine stand is equipped with a self-lock mechanism. However, if the transaxle is tilted, the self-lock mechanism could become inoperative. This could cause the transaxle to rotate accidentally, resulting in injury. Therefore, make sure that the transaxle is not tilted when it is on the engine stand. When turning the transaxle, grasp the rotation handle firmly.
- Always wear protective eye wear when using the air compressor. Otherwise, ATF or dirt particles blown off by the air compressor could get into the eyes.

Operation Cautions

- Prevent foreign matter penetration into the transaxle.
 - Clean the outside of the transaxle using steam or degreaser before disassembly.

Caution

- If the outside of the transaxle is cleaned, plug the position shown in the figure with packing tape and be careful that foreign matter, water, or degreaser does not penetrate the transaxle and connector.

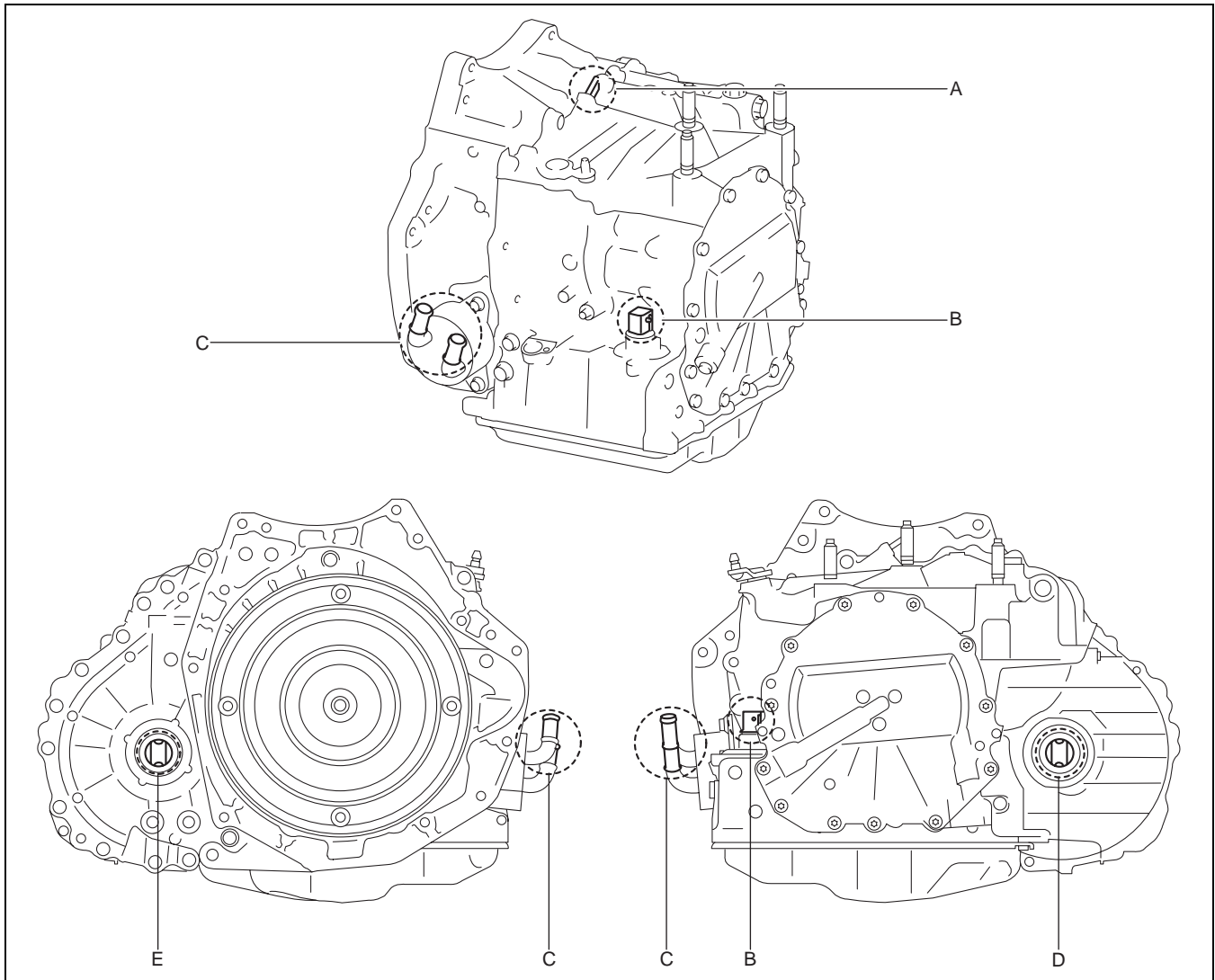

bfw1ua00000004

- A: Breather pipe
- B: Control valve body connector
- C: Oil cooler
- D: Oil seal
- E: Oil seal

AUTOMATIC TRANSAXLE

05-17

- To prevent dust penetration into the transaxle, perform the procedure in a dust free room.
- To prevent lint penetration into the transaxle, perform the procedure with bare hands or wearing vinyl gloves. Do not use cotton gloves or rag.
- Organize and store the disassembled parts to protect them from dust or dirt.
- Before assembly, verify that each part is clean and dried.
- Clean off remaining old sealant before applying new sealant.
- Do not clean the following parts, otherwise foreign matter or degreaser may penetrate the oil passage or internal part:
 - Control valve body (including the following parts):
 - ON/OFF solenoid
 - Oil pressure switch A
 - Oil pressure switch B
 - Coupler component
- Disassemble while looking for damage, cracks, deformation, scratches, and the assembly condition of parts.
- When servicing, be very careful not to get injured by the edges of parts.
- If ATF is dripping on the floor, wipe it off immediately because a slippery floor is dangerous.
- If the connecting part of a light-alloy part for the transaxle case is disassembled, disassemble it by lightly tapping using a plastic hammer. Do not twist the part or use a flathead screwdriver.
- Thoroughly inspect the foreign matter found in the transaxle or on the magnet to help determine the transaxle condition.
- If using a vise, secure the component using a protective plate (aluminum plate) to prevent component damage.
- Be very careful when handling electronic components.
 - If a connector is disconnected, do not pull the wiring harness. Pull the connector at a straight angle after releasing the lock.
 - Do not touch the terminal as the connector terminal could be damaged.
 - Verify that there is no foreign matter adhering to the connector before connecting the connector.
 - When connecting a connector, insert it straight until it is securely locked.
 - Do not apply impact to electronic components. Replace with a new component if one was dropped or received an impact.
- To prevent damage to parts, always use an air compressor adjusted to the indicated pressure.
- Always use ATF FZ for the ATF.
- Always use silicone sealant TB1217E for sealant.
- If the drive plate is replaced with a new one, immerse it in ATF (ATF FZ) for 2 hours or more to permeate the facing with ATF.
- Do not clean the drive plate using degreaser.
- Do not clean the internal part of the torque converter using degreaser.
- Do not clean the internal part of the oil cooler using degreaser.
- Do not clean aluminum and rubber parts using an alkaline agent.
- Do not clean rubber parts using white gasoline and kerosene.
- When assembling a part which is designated for replacement with every disassembly, always use a new part.
- Replace the damaged or deformed snap ring with a new one.

Required SSTs, Measuring Instruments, and Parts for Servicing

- SST
(See 05-60-1 SERVICE TOOLS.)
- Measuring instrument
 - Vernier caliper
 - Micrometer
 - Cylinder gauge or caliper gauge
 - Dial gauge
 - Magnetic stand
 - Depth gauge
 - Depth micrometer
 - Straight edge ruler (two of the same type)
 - Thickness gauge
 - Torque wrench

AUTOMATIC TRANSAXLE

- Part

Part name	Part number	Quantity	Comment
Bolt	9YA02 1440	3	M14×1.5 bolt, length to 100 mm {3.94 in}
Bolt	9YA02 1015	2	M10×1.5 bolt, length to 35 mm {1.4 in}
Bolt	9YA02 A220	4	M12×1.75 bolt, length to 40 mm {1.6 in}
Snap ring	FZ01 19 469	1	Measurement/adjustment for R-3-5 brake clearance
Shim	FZ01 19 2L1	1	Measurement/adjustment for total end play
ATF	—	—	ATF FZ
Sealant	—	—	Silicone sealant TB1217E

After Service Precaution

- After installing the overhauled transaxle to the vehicle, perform the procedure in the following order.

Note

- For the service procedure, verify the Workshop Manual.

1. TCM configuration

Caution

- Perform the TCM configuration only if the control valve body is replaced.

2. Initial learning
3. Mechanical system test
4. Road test

AUTOMATIC TRANSAXLE

AUTOMATIC TRANSAXLE LOCATION INDEX

id051700660200

Automatic Transaxle 1

05-17

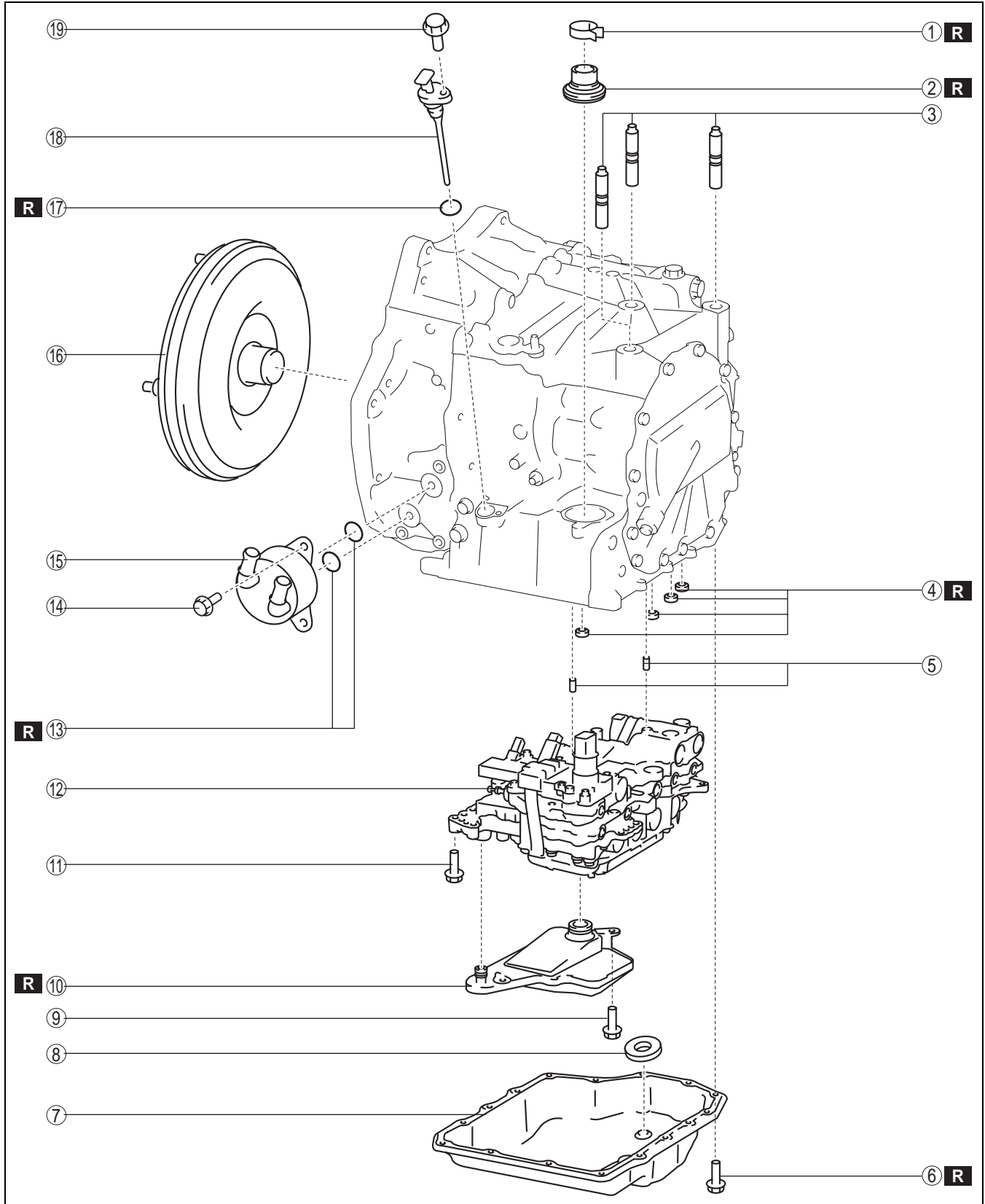

bfw1ua00000003

AUTOMATIC TRANSAXLE

1	Hose clamp (See 05-17-64 AUTOMATIC TRANSAXLE DISASSEMBLY.) (See 05-17-180 AUTOMATIC TRANSAXLE ASSEMBLY.)
2	Oil seal (See 05-17-64 AUTOMATIC TRANSAXLE DISASSEMBLY.) (See 05-17-180 AUTOMATIC TRANSAXLE ASSEMBLY.)
3	Stud bolt (See 05-17-64 AUTOMATIC TRANSAXLE DISASSEMBLY.) (See 05-17-180 AUTOMATIC TRANSAXLE ASSEMBLY.)
4	Gasket (See 05-17-64 AUTOMATIC TRANSAXLE DISASSEMBLY.) (See 05-17-180 AUTOMATIC TRANSAXLE ASSEMBLY.)
5	Dowel pin (See 05-17-64 AUTOMATIC TRANSAXLE DISASSEMBLY.) (See 05-17-180 AUTOMATIC TRANSAXLE ASSEMBLY.)
6	16 bolts (See 05-17-64 AUTOMATIC TRANSAXLE DISASSEMBLY.) (See 05-17-180 AUTOMATIC TRANSAXLE ASSEMBLY.)
7	Oil pan (See 05-17-64 AUTOMATIC TRANSAXLE DISASSEMBLY.) (See 05-17-180 AUTOMATIC TRANSAXLE ASSEMBLY.)
8	Magnet (See 05-17-64 AUTOMATIC TRANSAXLE DISASSEMBLY.) (See 05-17-180 AUTOMATIC TRANSAXLE ASSEMBLY.)
9	2 bolts (See 05-17-64 AUTOMATIC TRANSAXLE DISASSEMBLY.) (See 05-17-180 AUTOMATIC TRANSAXLE ASSEMBLY.)
10	Oil strainer (See 05-17-64 AUTOMATIC TRANSAXLE DISASSEMBLY.) (See 05-17-180 AUTOMATIC TRANSAXLE ASSEMBLY.)

11	11 bolts (See 05-17-64 AUTOMATIC TRANSAXLE DISASSEMBLY.) (See 05-17-180 AUTOMATIC TRANSAXLE ASSEMBLY.)
12	Control valve body (See 05-17-64 AUTOMATIC TRANSAXLE DISASSEMBLY.) (See 05-17-180 AUTOMATIC TRANSAXLE ASSEMBLY.) (See 05-17-25 Control Valve Body.)
13	O-ring (See 05-17-64 AUTOMATIC TRANSAXLE DISASSEMBLY.) (See 05-17-180 AUTOMATIC TRANSAXLE ASSEMBLY.)
14	3 bolts (See 05-17-64 AUTOMATIC TRANSAXLE DISASSEMBLY.) (See 05-17-180 AUTOMATIC TRANSAXLE ASSEMBLY.)
15	Oil cooler (See 05-17-64 AUTOMATIC TRANSAXLE DISASSEMBLY.) (See 05-17-180 AUTOMATIC TRANSAXLE ASSEMBLY.) (See 05-17-147 OIL COOLER CLEANING.) (See 05-17-177 OIL COOLER INSPECTION.)
16	Torque converter (See 05-17-64 AUTOMATIC TRANSAXLE DISASSEMBLY.) (See 05-17-180 AUTOMATIC TRANSAXLE ASSEMBLY.) (See 05-17-145 TORQUE CONVERTER CLEANING.) (See 05-17-154 TORQUE CONVERTER INSPECTION.)
17	O-ring (See 05-17-64 AUTOMATIC TRANSAXLE DISASSEMBLY.) (See 05-17-180 AUTOMATIC TRANSAXLE ASSEMBLY.)
18	Dipstick (See 05-17-64 AUTOMATIC TRANSAXLE DISASSEMBLY.) (See 05-17-180 AUTOMATIC TRANSAXLE ASSEMBLY.)
19	Bolt (See 05-17-64 AUTOMATIC TRANSAXLE DISASSEMBLY.) (See 05-17-180 AUTOMATIC TRANSAXLE ASSEMBLY.)

AUTOMATIC TRANSAXLE

Automatic Transaxle 2

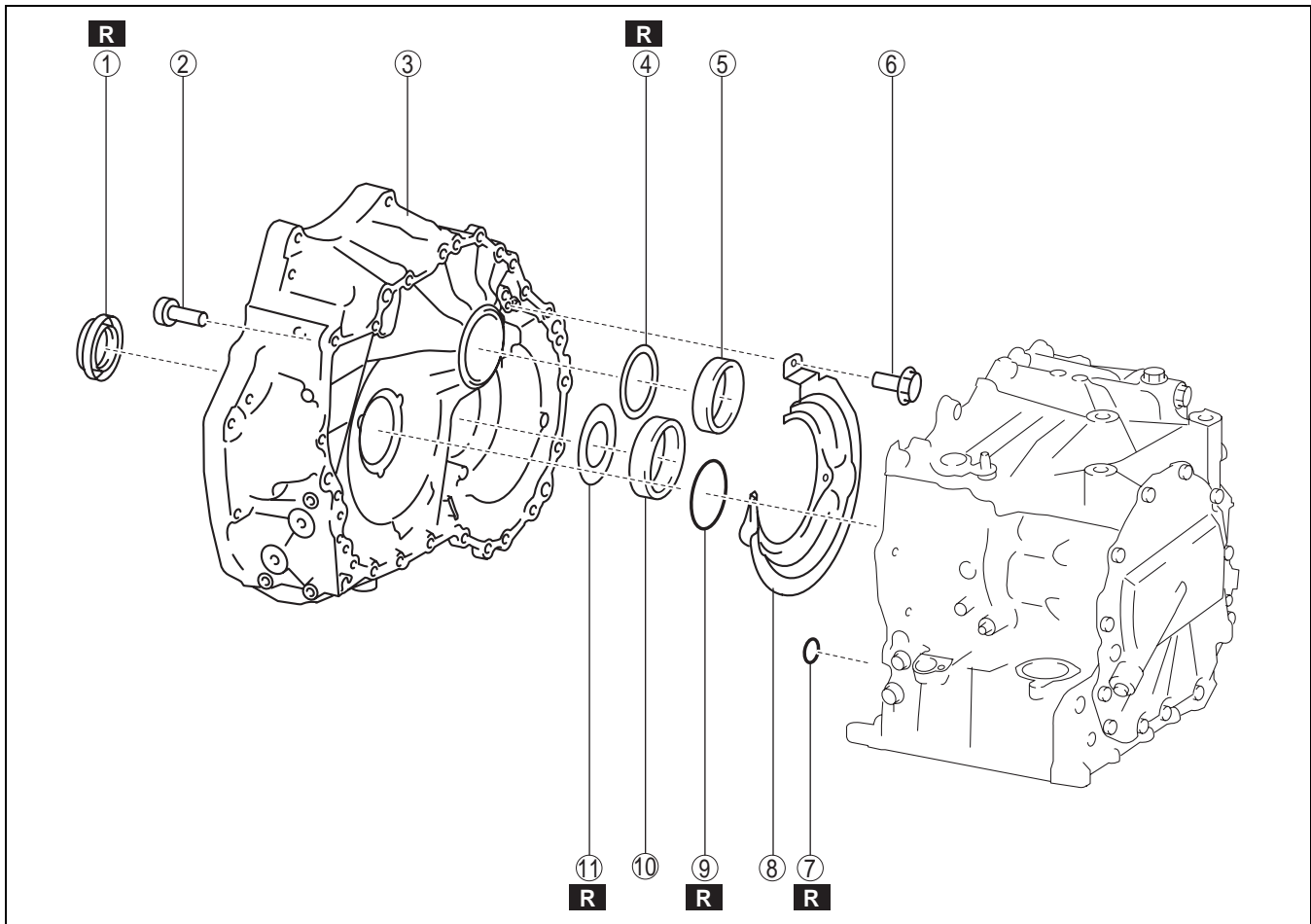

05-17

azzjjw00000287

1	Oil seal (See 05-17-64 AUTOMATIC TRANSAXLE DISASSEMBLY.) (See 05-17-180 AUTOMATIC TRANSAXLE ASSEMBLY.)
2	24 bolts (See 05-17-64 AUTOMATIC TRANSAXLE DISASSEMBLY.) (See 05-17-180 AUTOMATIC TRANSAXLE ASSEMBLY.)
3	Converter housing (See 05-17-64 AUTOMATIC TRANSAXLE DISASSEMBLY.) (See 05-17-180 AUTOMATIC TRANSAXLE ASSEMBLY.)
4	Shim (See 05-17-64 AUTOMATIC TRANSAXLE DISASSEMBLY.) (See 05-17-180 AUTOMATIC TRANSAXLE ASSEMBLY.) (See 05-17-364 SECONDARY GEAR AND OUTPUT GEAR PRELOAD MEASUREMENT/ADJUSTMENT.)
5	Bearing race (See 05-17-64 AUTOMATIC TRANSAXLE DISASSEMBLY.) (See 05-17-180 AUTOMATIC TRANSAXLE ASSEMBLY.)

6	3 bolts (See 05-17-64 AUTOMATIC TRANSAXLE DISASSEMBLY.) (See 05-17-180 AUTOMATIC TRANSAXLE ASSEMBLY.)
7	O-ring (See 05-17-64 AUTOMATIC TRANSAXLE DISASSEMBLY.) (See 05-17-180 AUTOMATIC TRANSAXLE ASSEMBLY.)
8	Baffle plate (See 05-17-64 AUTOMATIC TRANSAXLE DISASSEMBLY.) (See 05-17-180 AUTOMATIC TRANSAXLE ASSEMBLY.)
9	O-ring (See 05-17-64 AUTOMATIC TRANSAXLE DISASSEMBLY.) (See 05-17-180 AUTOMATIC TRANSAXLE ASSEMBLY.)
10	Bearing race (See 05-17-64 AUTOMATIC TRANSAXLE DISASSEMBLY.) (See 05-17-180 AUTOMATIC TRANSAXLE ASSEMBLY.)

AUTOMATIC TRANSAXLE

11	Shim (See 05-17-64 AUTOMATIC TRANSAXLE DISASSEMBLY.) (See 05-17-180 AUTOMATIC TRANSAXLE ASSEMBLY.) (See 05-17-375 RING GEAR AND DIFFERENTIAL PRELOAD MEASUREMENT/ADJUSTMENT.)
----	---

Automatic Transaxle 3

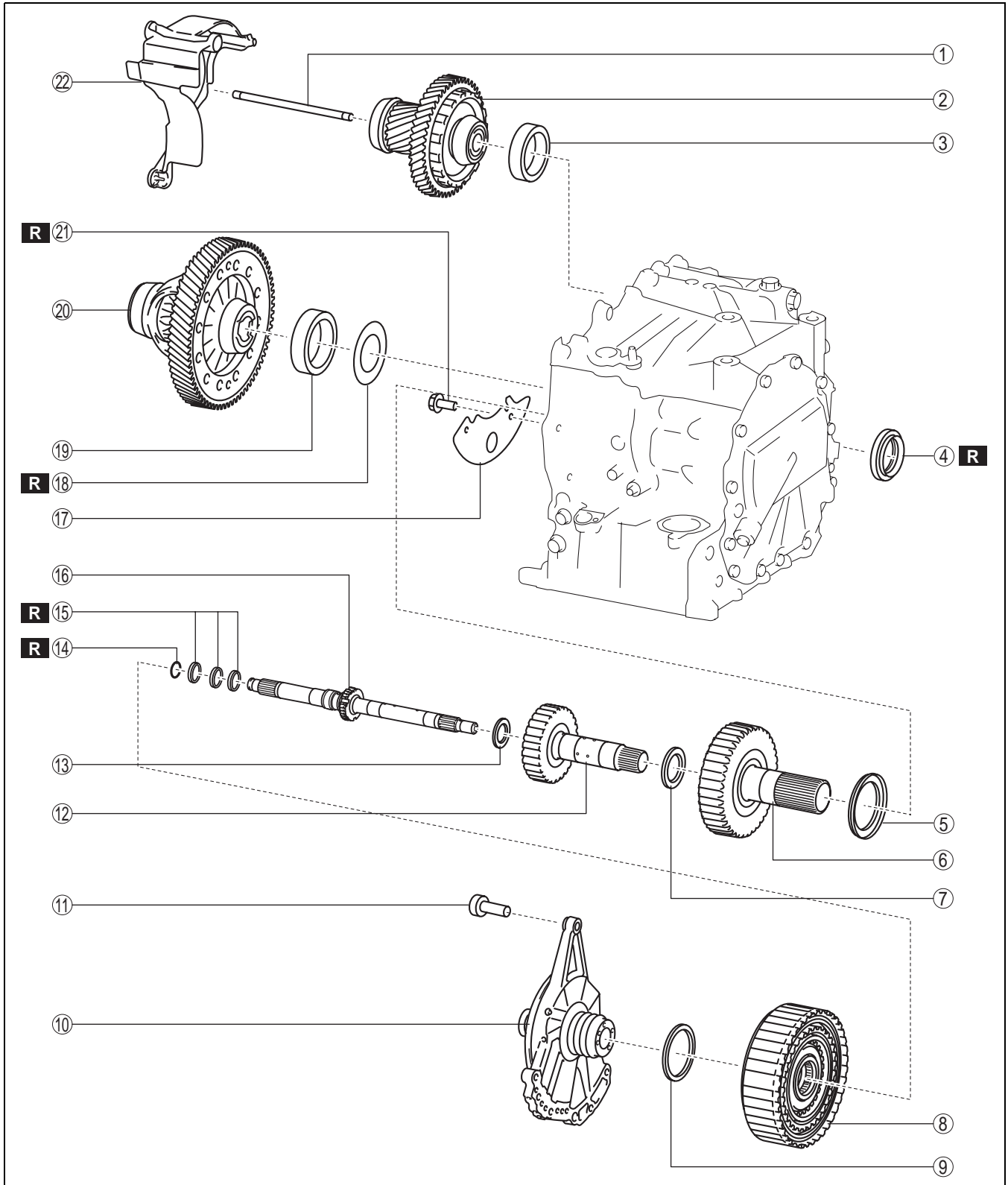

azzijw00001367

AUTOMATIC TRANSAXLE

1	Oil pipe (See 05-17-64 AUTOMATIC TRANSAXLE DISASSEMBLY.) (See 05-17-180 AUTOMATIC TRANSAXLE ASSEMBLY.)
2	Secondary gear and output gear (See 05-17-64 AUTOMATIC TRANSAXLE DISASSEMBLY.) (See 05-17-180 AUTOMATIC TRANSAXLE ASSEMBLY.) (See 05-17-19 Secondary Gear and Output Gear.)
3	Bearing race (See 05-17-64 AUTOMATIC TRANSAXLE DISASSEMBLY.) (See 05-17-180 AUTOMATIC TRANSAXLE ASSEMBLY.)
4	Oil seal (See 05-17-64 AUTOMATIC TRANSAXLE DISASSEMBLY.) (See 05-17-180 AUTOMATIC TRANSAXLE ASSEMBLY.)
5	Thrust needle bearing (See 05-17-64 AUTOMATIC TRANSAXLE DISASSEMBLY.) (See 05-17-180 AUTOMATIC TRANSAXLE ASSEMBLY.) (See 05-17-155 THRUST NEEDLE BEARING INSPECTION.)
6	Low clutch hub (See 05-17-64 AUTOMATIC TRANSAXLE DISASSEMBLY.) (See 05-17-180 AUTOMATIC TRANSAXLE ASSEMBLY.) (See 05-17-173 LOW CLUTCH HUB INSPECTION.)
7	Thrust needle bearing (See 05-17-64 AUTOMATIC TRANSAXLE DISASSEMBLY.) (See 05-17-180 AUTOMATIC TRANSAXLE ASSEMBLY.) (See 05-17-155 THRUST NEEDLE BEARING INSPECTION.)
8	Clutch component (See 05-17-64 AUTOMATIC TRANSAXLE DISASSEMBLY.) (See 05-17-180 AUTOMATIC TRANSAXLE ASSEMBLY.) (See 05-17-17 Clutch Component.)
9	Thrust needle bearing (See 05-17-64 AUTOMATIC TRANSAXLE DISASSEMBLY.) (See 05-17-180 AUTOMATIC TRANSAXLE ASSEMBLY.) (See 05-17-155 THRUST NEEDLE BEARING INSPECTION.)
10	Oil pump (See 05-17-64 AUTOMATIC TRANSAXLE DISASSEMBLY.) (See 05-17-180 AUTOMATIC TRANSAXLE ASSEMBLY.) (See 05-17-16 Oil Pump.)

11	7 bolts (See 05-17-64 AUTOMATIC TRANSAXLE DISASSEMBLY.) (See 05-17-180 AUTOMATIC TRANSAXLE ASSEMBLY.)
12	High clutch hub (See 05-17-64 AUTOMATIC TRANSAXLE DISASSEMBLY.) (See 05-17-180 AUTOMATIC TRANSAXLE ASSEMBLY.) (See 05-17-173 HIGH CLUTCH HUB INSPECTION.)
13	Thrust needle bearing (See 05-17-64 AUTOMATIC TRANSAXLE DISASSEMBLY.) (See 05-17-180 AUTOMATIC TRANSAXLE ASSEMBLY.) (See 05-17-155 THRUST NEEDLE BEARING INSPECTION.)
14	D-ring (See 05-17-64 AUTOMATIC TRANSAXLE DISASSEMBLY.) (See 05-17-180 AUTOMATIC TRANSAXLE ASSEMBLY.)
15	Seal ring (See 05-17-64 AUTOMATIC TRANSAXLE DISASSEMBLY.) (See 05-17-180 AUTOMATIC TRANSAXLE ASSEMBLY.)
16	Turbine shaft (See 05-17-64 AUTOMATIC TRANSAXLE DISASSEMBLY.) (See 05-17-180 AUTOMATIC TRANSAXLE ASSEMBLY.)
17	Baffle plate (See 05-17-64 AUTOMATIC TRANSAXLE DISASSEMBLY.) (See 05-17-180 AUTOMATIC TRANSAXLE ASSEMBLY.)
18	Shim (See 05-17-64 AUTOMATIC TRANSAXLE DISASSEMBLY.) (See 05-17-180 AUTOMATIC TRANSAXLE ASSEMBLY.)
19	Bearing race (See 05-17-64 AUTOMATIC TRANSAXLE DISASSEMBLY.) (See 05-17-180 AUTOMATIC TRANSAXLE ASSEMBLY.)
20	Ring gear and differential (See 05-17-64 AUTOMATIC TRANSAXLE DISASSEMBLY.) (See 05-17-180 AUTOMATIC TRANSAXLE ASSEMBLY.) (See 05-17-20 Ring Gear and Differential.)
21	2 bolts (See 05-17-64 AUTOMATIC TRANSAXLE DISASSEMBLY.) (See 05-17-180 AUTOMATIC TRANSAXLE ASSEMBLY.)
22	Baffle plate (See 05-17-64 AUTOMATIC TRANSAXLE DISASSEMBLY.) (See 05-17-180 AUTOMATIC TRANSAXLE ASSEMBLY.)

AUTOMATIC TRANSAXLE

Automatic Transaxle 4

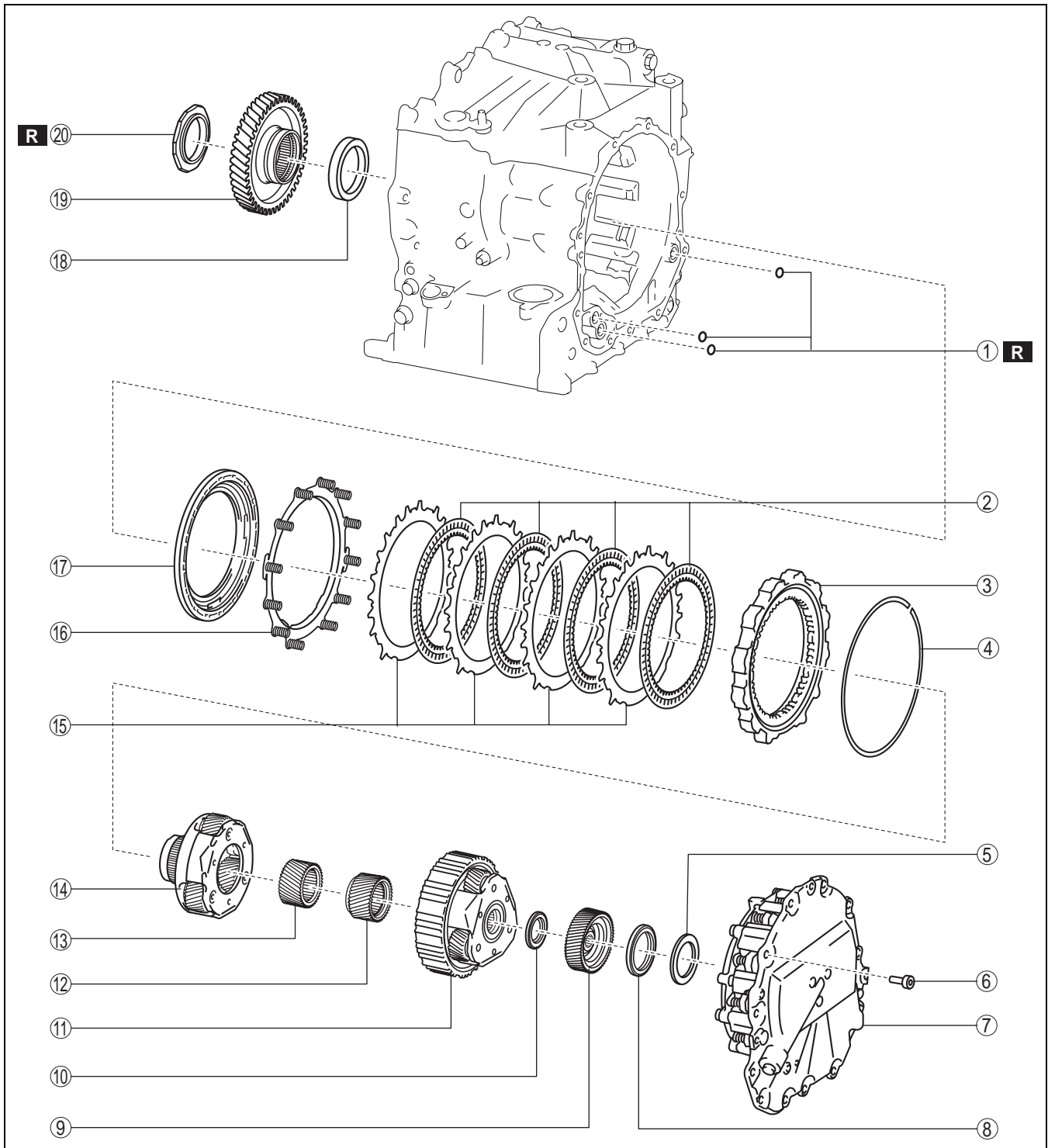

azzjiw00000289

1	<p>O-ring (See 05-17-64 AUTOMATIC TRANSAXLE DISASSEMBLY.) (See 05-17-180 AUTOMATIC TRANSAXLE ASSEMBLY.)</p>
2	<p>Drive plate (See 05-17-64 AUTOMATIC TRANSAXLE DISASSEMBLY.) (See 05-17-180 AUTOMATIC TRANSAXLE ASSEMBLY.) (See 05-17-170 LOW AND REVERSE BRAKE INSPECTION.)</p>

3	<p>One-way clutch (See 05-17-64 AUTOMATIC TRANSAXLE DISASSEMBLY.) (See 05-17-180 AUTOMATIC TRANSAXLE ASSEMBLY.) (See 05-17-172 ONE-WAY CLUTCH INSPECTION.)</p>
---	--

AUTOMATIC TRANSAXLE

4	Snap ring (See 05-17-64 AUTOMATIC TRANSAXLE DISASSEMBLY.) (See 05-17-180 AUTOMATIC TRANSAXLE ASSEMBLY.) (See 05-17-353 LOW AND REVERSE BRAKE CLEARANCE MEASUREMENT/ADJUSTMENT.)
5	Shim (See 05-17-64 AUTOMATIC TRANSAXLE DISASSEMBLY.) (See 05-17-180 AUTOMATIC TRANSAXLE ASSEMBLY.) (See 05-17-385 TOTAL END PLAY MEASUREMENT/ADJUSTMENT.)
6	12 bolts (See 05-17-64 AUTOMATIC TRANSAXLE DISASSEMBLY.) (See 05-17-180 AUTOMATIC TRANSAXLE ASSEMBLY.)
7	End cover component (See 05-17-64 AUTOMATIC TRANSAXLE DISASSEMBLY.) (See 05-17-180 AUTOMATIC TRANSAXLE ASSEMBLY.) (See 05-17-22 End Cover Component.)
8	Thrust needle bearing (See 05-17-64 AUTOMATIC TRANSAXLE DISASSEMBLY.) (See 05-17-180 AUTOMATIC TRANSAXLE ASSEMBLY.) (See 05-17-155 THRUST NEEDLE BEARING INSPECTION.)
9	Reduction sun gear (See 05-17-64 AUTOMATIC TRANSAXLE DISASSEMBLY.) (See 05-17-180 AUTOMATIC TRANSAXLE ASSEMBLY.)
10	Thrust needle bearing (See 05-17-64 AUTOMATIC TRANSAXLE DISASSEMBLY.) (See 05-17-180 AUTOMATIC TRANSAXLE ASSEMBLY.) (See 05-17-155 THRUST NEEDLE BEARING INSPECTION.)
11	Rear planetary gear (See 05-17-64 AUTOMATIC TRANSAXLE DISASSEMBLY.) (See 05-17-180 AUTOMATIC TRANSAXLE ASSEMBLY.) (See 05-17-18 Rear Planetary Gear.)

12	Rear sun gear (See 05-17-64 AUTOMATIC TRANSAXLE DISASSEMBLY.) (See 05-17-180 AUTOMATIC TRANSAXLE ASSEMBLY.)
13	Front sun gear (See 05-17-64 AUTOMATIC TRANSAXLE DISASSEMBLY.) (See 05-17-180 AUTOMATIC TRANSAXLE ASSEMBLY.)
14	Front planetary gear (See 05-17-64 AUTOMATIC TRANSAXLE DISASSEMBLY.) (See 05-17-180 AUTOMATIC TRANSAXLE ASSEMBLY.) (See 05-17-155 FRONT PLANETARY GEAR INSPECTION.)
15	Driven plate (See 05-17-64 AUTOMATIC TRANSAXLE DISASSEMBLY.) (See 05-17-180 AUTOMATIC TRANSAXLE ASSEMBLY.)
16	Springs and retainer component (See 05-17-64 AUTOMATIC TRANSAXLE DISASSEMBLY.) (See 05-17-180 AUTOMATIC TRANSAXLE ASSEMBLY.)
17	Low and reverse brake piston (See 05-17-64 AUTOMATIC TRANSAXLE DISASSEMBLY.) (See 05-17-180 AUTOMATIC TRANSAXLE ASSEMBLY.)
18	Angular contact ball bearing (See 05-17-64 AUTOMATIC TRANSAXLE DISASSEMBLY.)
19	Primary gear (See 05-17-64 AUTOMATIC TRANSAXLE DISASSEMBLY.) (See 05-17-180 AUTOMATIC TRANSAXLE ASSEMBLY.)
20	Locknut (See 05-17-64 AUTOMATIC TRANSAXLE DISASSEMBLY.) (See 05-17-180 AUTOMATIC TRANSAXLE ASSEMBLY.)

05-17

AUTOMATIC TRANSAXLE

Automatic Transaxle 5

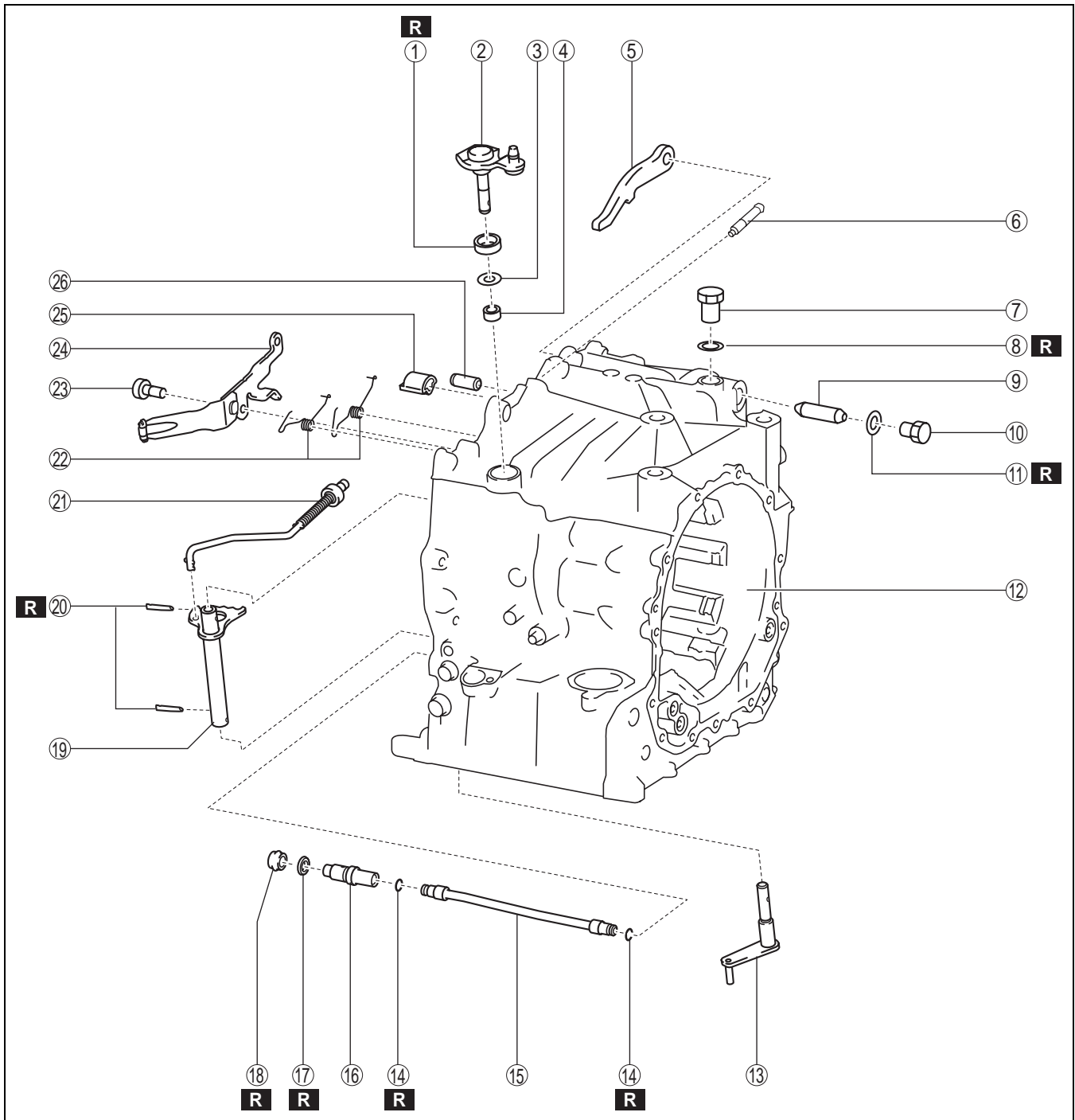

azzjiw00000532

1	Oil seal (See 05-17-64 AUTOMATIC TRANSAXLE DISASSEMBLY.) (See 05-17-180 AUTOMATIC TRANSAXLE ASSEMBLY.) (See 05-17-41 OIL SEAL (PARKING SHIFT LEVER) REPLACEMENT.)
2	Parking shift lever component (See 05-17-64 AUTOMATIC TRANSAXLE DISASSEMBLY.) (See 05-17-180 AUTOMATIC TRANSAXLE ASSEMBLY.)

3	Washer (See 05-17-64 AUTOMATIC TRANSAXLE DISASSEMBLY.) (See 05-17-180 AUTOMATIC TRANSAXLE ASSEMBLY.)
4	Radial needle bearing (See 05-17-180 AUTOMATIC TRANSAXLE ASSEMBLY.)
5	Parking pawl (See 05-17-64 AUTOMATIC TRANSAXLE DISASSEMBLY.) (See 05-17-180 AUTOMATIC TRANSAXLE ASSEMBLY.)

AUTOMATIC TRANSAXLE

6	Breather pipe (See 05-17-180 AUTOMATIC TRANSAXLE ASSEMBLY.)
7	Plug (See 05-17-64 AUTOMATIC TRANSAXLE DISASSEMBLY.) (See 05-17-180 AUTOMATIC TRANSAXLE ASSEMBLY.)
8	Gasket (See 05-17-64 AUTOMATIC TRANSAXLE DISASSEMBLY.) (See 05-17-180 AUTOMATIC TRANSAXLE ASSEMBLY.)
9	Parking pawl shaft (See 05-17-64 AUTOMATIC TRANSAXLE DISASSEMBLY.) (See 05-17-180 AUTOMATIC TRANSAXLE ASSEMBLY.)
10	Plug (See 05-17-64 AUTOMATIC TRANSAXLE DISASSEMBLY.) (See 05-17-180 AUTOMATIC TRANSAXLE ASSEMBLY.)
11	Gasket (See 05-17-64 AUTOMATIC TRANSAXLE DISASSEMBLY.) (See 05-17-180 AUTOMATIC TRANSAXLE ASSEMBLY.)
12	Transaxle case (See 05-17-64 AUTOMATIC TRANSAXLE DISASSEMBLY.) (See 05-17-180 AUTOMATIC TRANSAXLE ASSEMBLY.)
13	Parking assist lever component (See 05-17-64 AUTOMATIC TRANSAXLE DISASSEMBLY.) (See 05-17-180 AUTOMATIC TRANSAXLE ASSEMBLY.)
14	O-ring (See 05-17-64 AUTOMATIC TRANSAXLE DISASSEMBLY.) (See 05-17-180 AUTOMATIC TRANSAXLE ASSEMBLY.)
15	Oil pipe (See 05-17-64 AUTOMATIC TRANSAXLE DISASSEMBLY.) (See 05-17-180 AUTOMATIC TRANSAXLE ASSEMBLY.)
16	Connector (See 05-17-64 AUTOMATIC TRANSAXLE DISASSEMBLY.) (See 05-17-180 AUTOMATIC TRANSAXLE ASSEMBLY.)

17	Gasket (See 05-17-64 AUTOMATIC TRANSAXLE DISASSEMBLY.) (See 05-17-180 AUTOMATIC TRANSAXLE ASSEMBLY.)
18	Gasket (See 05-17-64 AUTOMATIC TRANSAXLE DISASSEMBLY.) (See 05-17-180 AUTOMATIC TRANSAXLE ASSEMBLY.)
19	Manual plate component (See 05-17-64 AUTOMATIC TRANSAXLE DISASSEMBLY.) (See 05-17-180 AUTOMATIC TRANSAXLE ASSEMBLY.)
20	Roll pin (See 05-17-64 AUTOMATIC TRANSAXLE DISASSEMBLY.) (See 05-17-180 AUTOMATIC TRANSAXLE ASSEMBLY.)
21	Parking rod component (See 05-17-64 AUTOMATIC TRANSAXLE DISASSEMBLY.) (See 05-17-180 AUTOMATIC TRANSAXLE ASSEMBLY.)
22	Pawl return spring (See 05-17-64 AUTOMATIC TRANSAXLE DISASSEMBLY.) (See 05-17-180 AUTOMATIC TRANSAXLE ASSEMBLY.)
23	2 bolts (See 05-17-64 AUTOMATIC TRANSAXLE DISASSEMBLY.) (See 05-17-180 AUTOMATIC TRANSAXLE ASSEMBLY.)
24	Detent bracket component (See 05-17-64 AUTOMATIC TRANSAXLE DISASSEMBLY.) (See 05-17-180 AUTOMATIC TRANSAXLE ASSEMBLY.)
25	Support actuator (See 05-17-64 AUTOMATIC TRANSAXLE DISASSEMBLY.) (See 05-17-180 AUTOMATIC TRANSAXLE ASSEMBLY.)
26	Parking pawl pin (See 05-17-64 AUTOMATIC TRANSAXLE DISASSEMBLY.) (See 05-17-180 AUTOMATIC TRANSAXLE ASSEMBLY.)

05-17

AUTOMATIC TRANSAXLE

Oil Pump

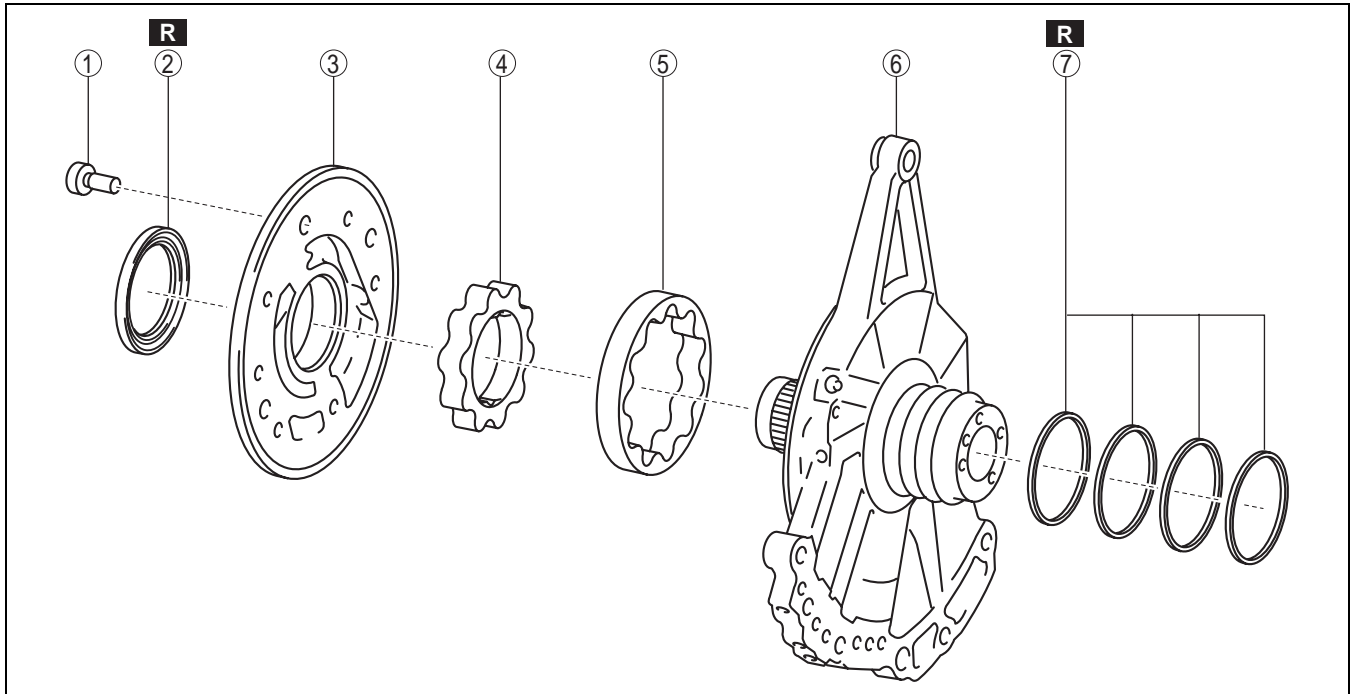

azzjjw00000291

1	7 bolts (See 05-17-115 OIL PUMP DISASSEMBLY.) (See 05-17-243 OIL PUMP ASSEMBLY.)
2	Oil seal (See 05-17-115 OIL PUMP DISASSEMBLY.) (See 05-17-243 OIL PUMP ASSEMBLY.) (See 05-17-29 OIL SEAL (OIL PUMP) REPLACEMENT.)
3	Oil pump cover (See 05-17-115 OIL PUMP DISASSEMBLY.) (See 05-17-243 OIL PUMP ASSEMBLY.) (See 05-17-174 OIL PUMP INSPECTION.)

4	Inner rotor (See 05-17-115 OIL PUMP DISASSEMBLY.) (See 05-17-243 OIL PUMP ASSEMBLY.) (See 05-17-174 OIL PUMP INSPECTION.)
5	Outer rotor (See 05-17-115 OIL PUMP DISASSEMBLY.) (See 05-17-243 OIL PUMP ASSEMBLY.) (See 05-17-174 OIL PUMP INSPECTION.)
6	Oil pump housing (See 05-17-115 OIL PUMP DISASSEMBLY.) (See 05-17-243 OIL PUMP ASSEMBLY.) (See 05-17-174 OIL PUMP INSPECTION.)
7	Seal ring (See 05-17-115 OIL PUMP DISASSEMBLY.) (See 05-17-243 OIL PUMP ASSEMBLY.)

AUTOMATIC TRANSAXLE

Clutch Component

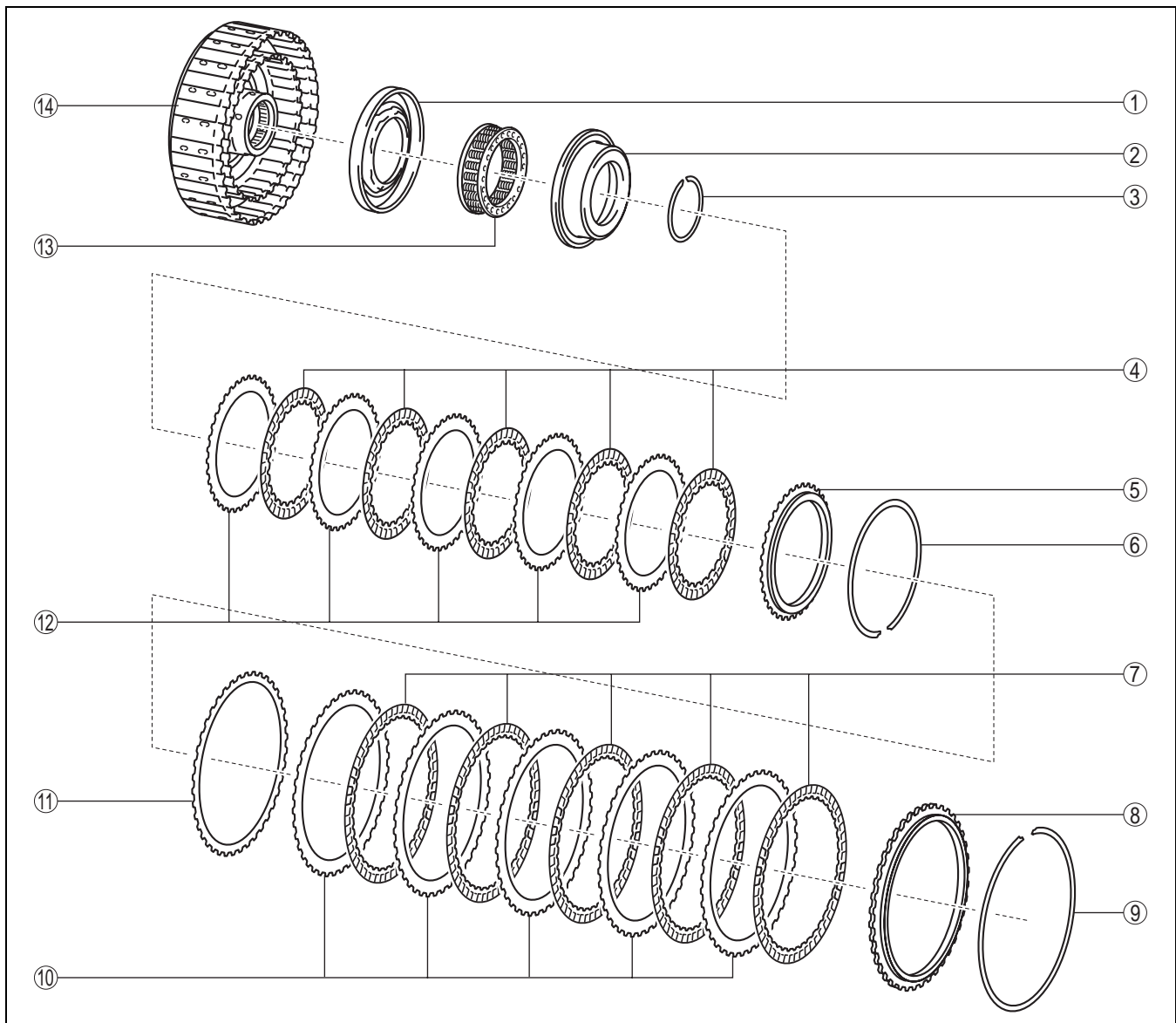

05-17

azzjjw00000292

1	High clutch piston (See 05-17-104 CLUTCH COMPONENT DISASSEMBLY.) (See 05-17-247 CLUTCH COMPONENT ASSEMBLY.)
2	Seal plate (See 05-17-104 CLUTCH COMPONENT DISASSEMBLY.) (See 05-17-247 CLUTCH COMPONENT ASSEMBLY.)
3	Snap ring (See 05-17-104 CLUTCH COMPONENT DISASSEMBLY.) (See 05-17-247 CLUTCH COMPONENT ASSEMBLY.)
4	Drive plate (See 05-17-104 CLUTCH COMPONENT DISASSEMBLY.) (See 05-17-247 CLUTCH COMPONENT ASSEMBLY.) (See 05-17-169 HIGH CLUTCH INSPECTION.)

5	Retaining plate (See 05-17-104 CLUTCH COMPONENT DISASSEMBLY.) (See 05-17-247 CLUTCH COMPONENT ASSEMBLY.)
6	Snap ring (See 05-17-104 CLUTCH COMPONENT DISASSEMBLY.) (See 05-17-247 CLUTCH COMPONENT ASSEMBLY.) (See 05-17-317 HIGH CLUTCH CLEARANCE MEASUREMENT/ADJUSTMENT.)
7	Drive plate (See 05-17-104 CLUTCH COMPONENT DISASSEMBLY.) (See 05-17-247 CLUTCH COMPONENT ASSEMBLY.) (See 05-17-169 LOW CLUTCH INSPECTION.)
8	Retaining plate (See 05-17-104 CLUTCH COMPONENT DISASSEMBLY.) (See 05-17-247 CLUTCH COMPONENT ASSEMBLY.)

AUTOMATIC TRANSAXLE

9	Snap ring (See 05-17-104 CLUTCH COMPONENT DISASSEMBLY.) (See 05-17-247 CLUTCH COMPONENT ASSEMBLY.) (See 05-17-327 LOW CLUTCH CLEARANCE MEASUREMENT/ADJUSTMENT.)	12	Driven plate (See 05-17-104 CLUTCH COMPONENT DISASSEMBLY.) (See 05-17-247 CLUTCH COMPONENT ASSEMBLY.)
10	Driven plate (See 05-17-104 CLUTCH COMPONENT DISASSEMBLY.) (See 05-17-247 CLUTCH COMPONENT ASSEMBLY.)	13	Springs and retainer component (See 05-17-104 CLUTCH COMPONENT DISASSEMBLY.) (See 05-17-247 CLUTCH COMPONENT ASSEMBLY.) (See 05-17-169 HIGH CLUTCH INSPECTION.)
11	Wave spring (See 05-17-104 CLUTCH COMPONENT DISASSEMBLY.) (See 05-17-247 CLUTCH COMPONENT ASSEMBLY.)	14	High clutch drum component (See 05-17-104 CLUTCH COMPONENT DISASSEMBLY.) (See 05-17-247 CLUTCH COMPONENT ASSEMBLY.) (See 05-17-169 HIGH CLUTCH INSPECTION.)

Rear Planetary Gear

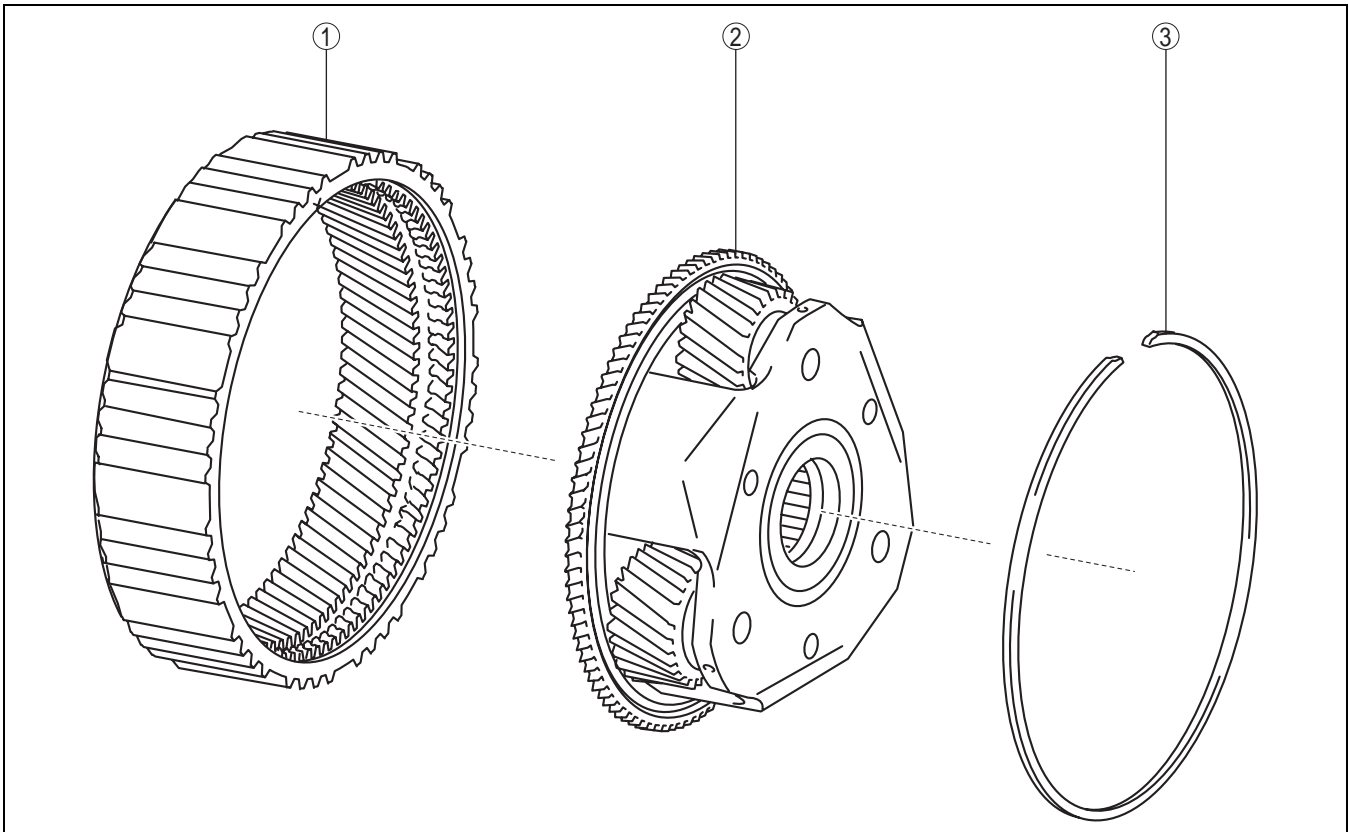

azzjw00000293

1	Front internal gear (See 05-17-117 REAR PLANETARY GEAR DISASSEMBLY.) (See 05-17-259 REAR PLANETARY GEAR ASSEMBLY.)	3	Snap ring (See 05-17-117 REAR PLANETARY GEAR DISASSEMBLY.) (See 05-17-259 REAR PLANETARY GEAR ASSEMBLY.)
2	Rear planetary carrier (See 05-17-117 REAR PLANETARY GEAR DISASSEMBLY.) (See 05-17-259 REAR PLANETARY GEAR ASSEMBLY.) (See 05-17-158 REAR PLANETARY GEAR INSPECTION.)		

AUTOMATIC TRANSAXLE

Secondary Gear and Output Gear

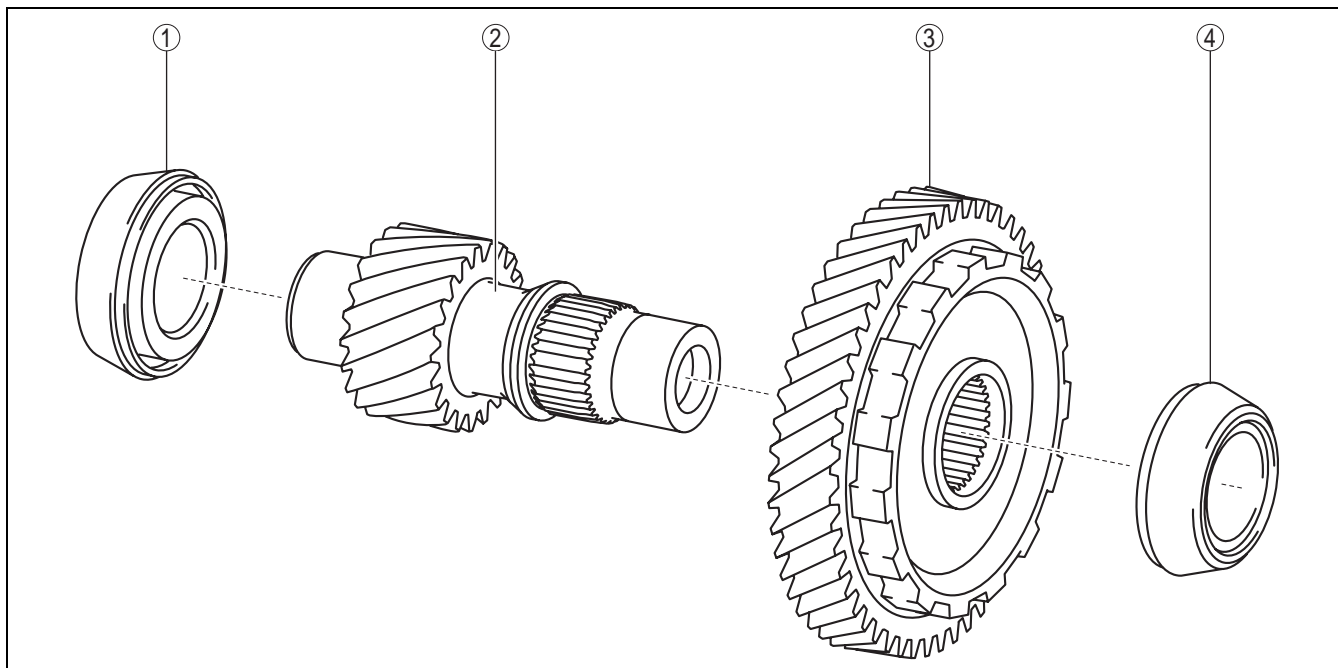

05-17

azzjjw00000294

1	<p>Tapered roller bearing (See 05-17-119 SECONDARY GEAR AND OUTPUT GEAR DISASSEMBLY.) (See 05-17-263 SECONDARY GEAR AND OUTPUT GEAR ASSEMBLY.) (See 05-17-163 SECONDARY GEAR AND OUTPUT GEAR INSPECTION.)</p>
2	<p>Output gear (See 05-17-119 SECONDARY GEAR AND OUTPUT GEAR DISASSEMBLY.) (See 05-17-263 SECONDARY GEAR AND OUTPUT GEAR ASSEMBLY.)</p>

3	<p>Secondary gear (See 05-17-119 SECONDARY GEAR AND OUTPUT GEAR DISASSEMBLY.) (See 05-17-263 SECONDARY GEAR AND OUTPUT GEAR ASSEMBLY.)</p>
4	<p>Tapered roller bearing (See 05-17-119 SECONDARY GEAR AND OUTPUT GEAR DISASSEMBLY.) (See 05-17-263 SECONDARY GEAR AND OUTPUT GEAR ASSEMBLY.) (See 05-17-163 SECONDARY GEAR AND OUTPUT GEAR INSPECTION.)</p>

AUTOMATIC TRANSAXLE

Ring Gear and Differential

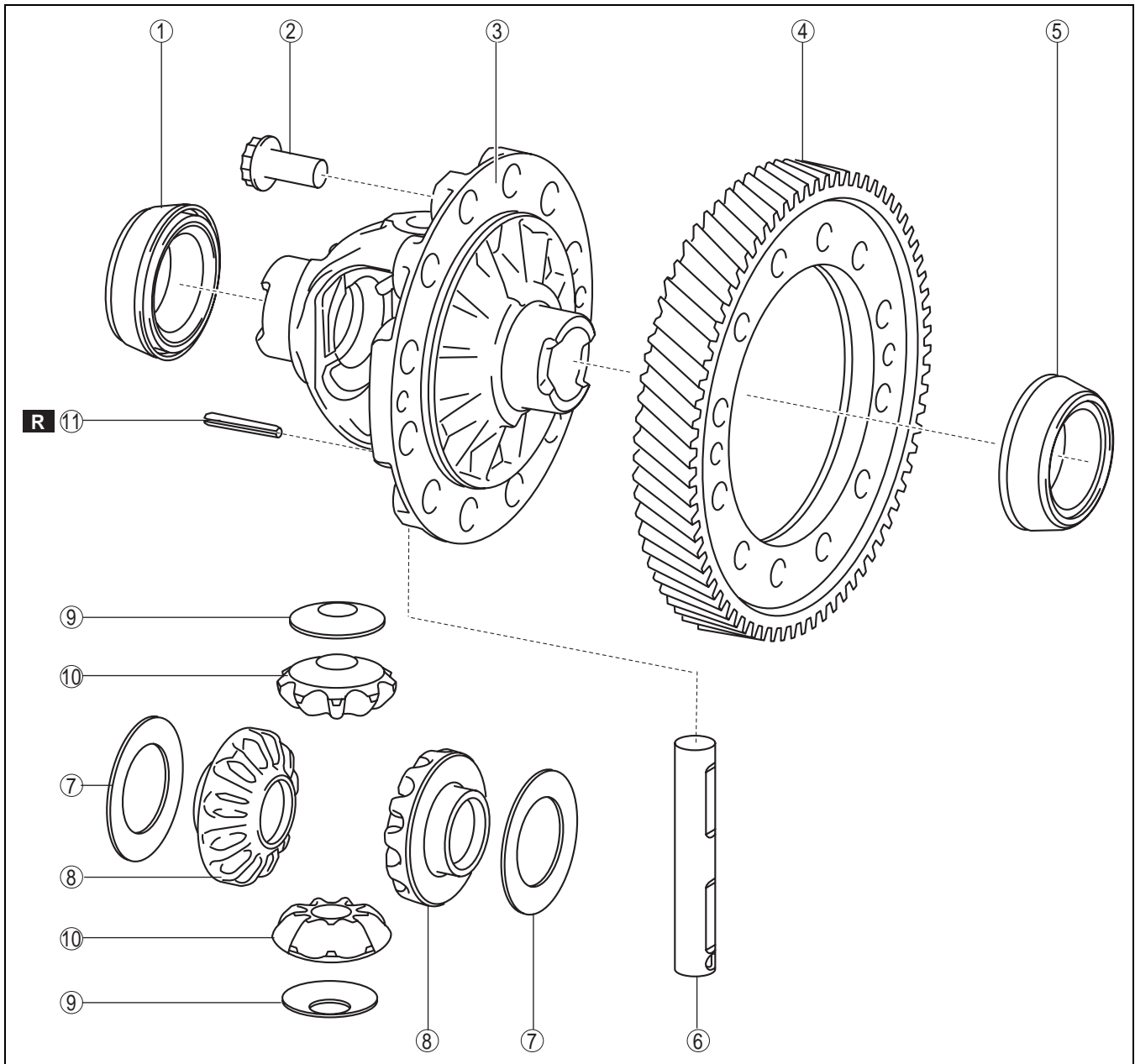

azzjw00001436

1	<p>Tapered roller bearing (See 05-17-121 RING GEAR AND DIFFERENTIAL DISASSEMBLY.) (See 05-17-266 RING GEAR AND DIFFERENTIAL ASSEMBLY.) (See 05-17-165 RING GEAR AND DIFFERENTIAL INSPECTION.)</p>
2	<p>12 bolts (See 05-17-121 RING GEAR AND DIFFERENTIAL DISASSEMBLY.) (See 05-17-266 RING GEAR AND DIFFERENTIAL ASSEMBLY.)</p>
3	<p>Differential gear case (See 05-17-121 RING GEAR AND DIFFERENTIAL DISASSEMBLY.) (See 05-17-266 RING GEAR AND DIFFERENTIAL ASSEMBLY.) (See 05-17-165 RING GEAR AND DIFFERENTIAL INSPECTION.)</p>

4	<p>Ring gear (See 05-17-121 RING GEAR AND DIFFERENTIAL DISASSEMBLY.) (See 05-17-266 RING GEAR AND DIFFERENTIAL ASSEMBLY.)</p>
5	<p>Tapered roller bearing (See 05-17-121 RING GEAR AND DIFFERENTIAL DISASSEMBLY.) (See 05-17-266 RING GEAR AND DIFFERENTIAL ASSEMBLY.) (See 05-17-165 RING GEAR AND DIFFERENTIAL INSPECTION.)</p>
6	<p>Pinion shaft (See 05-17-121 RING GEAR AND DIFFERENTIAL DISASSEMBLY.) (See 05-17-266 RING GEAR AND DIFFERENTIAL ASSEMBLY.)</p>

AUTOMATIC TRANSAXLE

7	Thrust washer (See 05-17-121 RING GEAR AND DIFFERENTIAL DISASSEMBLY.) (See 05-17-266 RING GEAR AND DIFFERENTIAL ASSEMBLY.) (See 05-17-303 DIFFERENTIAL BACKLASH MEASUREMENT/ADJUSTMENT.)
8	Side gear (See 05-17-121 RING GEAR AND DIFFERENTIAL DISASSEMBLY.) (See 05-17-266 RING GEAR AND DIFFERENTIAL ASSEMBLY.)

9	Thrust washer (See 05-17-121 RING GEAR AND DIFFERENTIAL DISASSEMBLY.) (See 05-17-266 RING GEAR AND DIFFERENTIAL ASSEMBLY.)
10	Pinion gear (See 05-17-121 RING GEAR AND DIFFERENTIAL DISASSEMBLY.) (See 05-17-266 RING GEAR AND DIFFERENTIAL ASSEMBLY.)
11	Roll pin (See 05-17-121 RING GEAR AND DIFFERENTIAL DISASSEMBLY.) (See 05-17-266 RING GEAR AND DIFFERENTIAL ASSEMBLY.)

05-17

AUTOMATIC TRANSAXLE

End Cover Component

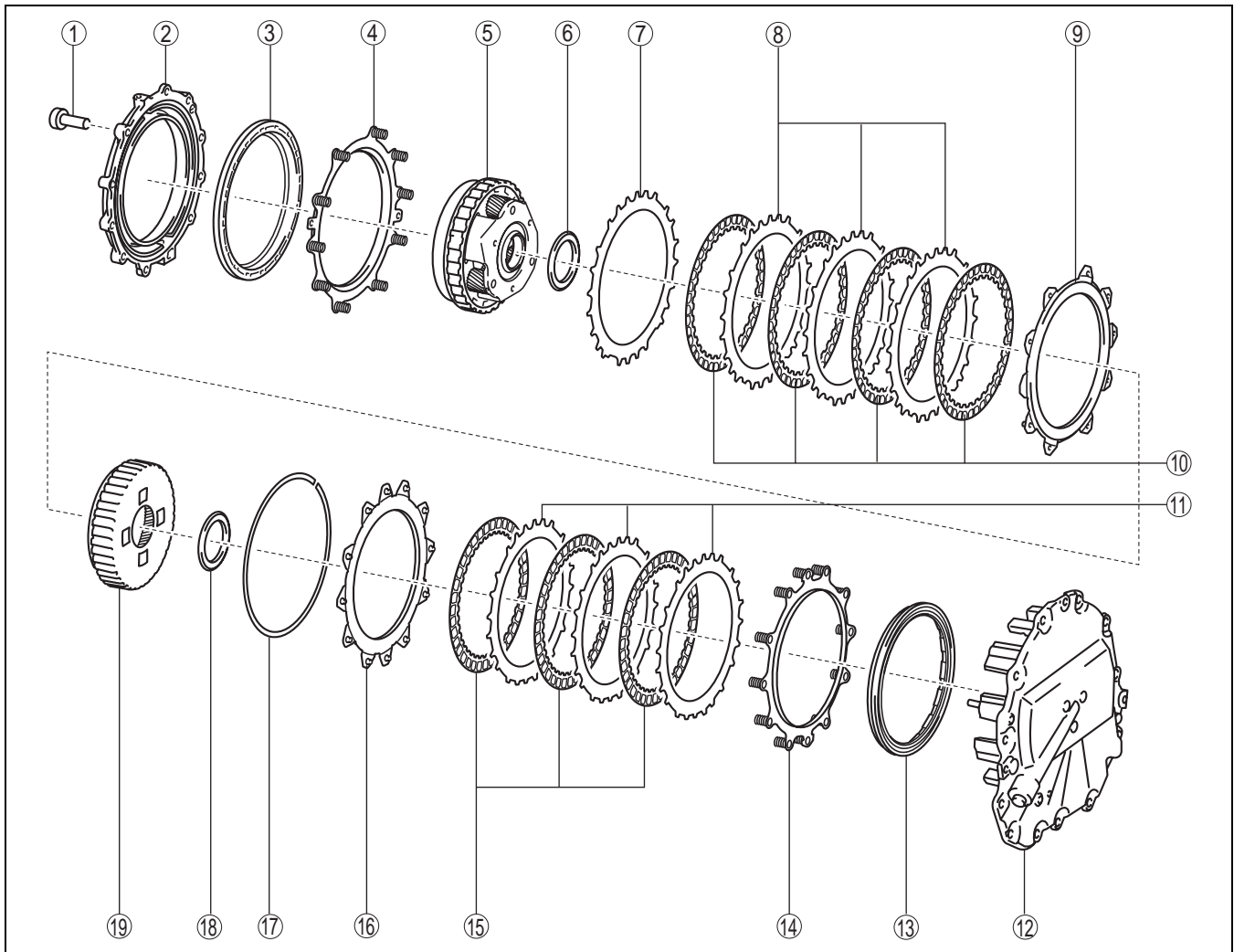

azzjw00000296

1	8 bolts (See 05-17-128 END COVER COMPONENT DISASSEMBLY.) (See 05-17-273 END COVER COMPONENT ASSEMBLY.)
2	Brake housing (See 05-17-128 END COVER COMPONENT DISASSEMBLY.) (See 05-17-273 END COVER COMPONENT ASSEMBLY.)
3	2-6 brake piston (See 05-17-128 END COVER COMPONENT DISASSEMBLY.) (See 05-17-273 END COVER COMPONENT ASSEMBLY.)
4	Springs and retainer component (See 05-17-128 END COVER COMPONENT DISASSEMBLY.) (See 05-17-273 END COVER COMPONENT ASSEMBLY.)
5	Reduction planetary gear (See 05-17-128 END COVER COMPONENT DISASSEMBLY.) (See 05-17-273 END COVER COMPONENT ASSEMBLY.) (See 05-17-24 Reduction Planetary Gear.)

6	Thrust needle bearing (See 05-17-128 END COVER COMPONENT DISASSEMBLY.) (See 05-17-273 END COVER COMPONENT ASSEMBLY.) (See 05-17-155 THRUST NEEDLE BEARING INSPECTION.)
7	Retaining plate (See 05-17-128 END COVER COMPONENT DISASSEMBLY.) (See 05-17-273 END COVER COMPONENT ASSEMBLY.) (See 05-17-347 2-6 BRAKE CLEARANCE MEASUREMENT/ADJUSTMENT.)
8	Driven plate (See 05-17-128 END COVER COMPONENT DISASSEMBLY.) (See 05-17-273 END COVER COMPONENT ASSEMBLY.)
9	Retaining plate (See 05-17-128 END COVER COMPONENT DISASSEMBLY.) (See 05-17-273 END COVER COMPONENT ASSEMBLY.)

AUTOMATIC TRANSAXLE

10	Drive plate (See 05-17-128 END COVER COMPONENT DISASSEMBLY.) (See 05-17-273 END COVER COMPONENT ASSEMBLY.) (See 05-17-171 2-6 BRAKE INSPECTION.)
11	Driven plate (See 05-17-128 END COVER COMPONENT DISASSEMBLY.) (See 05-17-273 END COVER COMPONENT ASSEMBLY.)
12	End cover (See 05-17-128 END COVER COMPONENT DISASSEMBLY.) (See 05-17-273 END COVER COMPONENT ASSEMBLY.) (See 05-17-177 END COVER INSPECTION.)
13	R-3-5 brake piston (See 05-17-128 END COVER COMPONENT DISASSEMBLY.) (See 05-17-273 END COVER COMPONENT ASSEMBLY.)
14	Springs and retainer component (See 05-17-128 END COVER COMPONENT DISASSEMBLY.) (See 05-17-273 END COVER COMPONENT ASSEMBLY.)

15	Drive plate (See 05-17-128 END COVER COMPONENT DISASSEMBLY.) (See 05-17-273 END COVER COMPONENT ASSEMBLY.) (See 05-17-171 R-3-5 BRAKE INSPECTION.)
16	Retaining plate (See 05-17-128 END COVER COMPONENT DISASSEMBLY.) (See 05-17-273 END COVER COMPONENT ASSEMBLY.)
17	Snap ring (See 05-17-128 END COVER COMPONENT DISASSEMBLY.) (See 05-17-273 END COVER COMPONENT ASSEMBLY.) (See 05-17-339 R-3-5 BRAKE CLEARANCE MEASUREMENT/ADJUSTMENT.)
18	Thrust needle bearing (See 05-17-128 END COVER COMPONENT DISASSEMBLY.) (See 05-17-273 END COVER COMPONENT ASSEMBLY.) (See 05-17-155 THRUST NEEDLE BEARING INSPECTION.)
19	Reduction internal gear (See 05-17-128 END COVER COMPONENT DISASSEMBLY.) (See 05-17-273 END COVER COMPONENT ASSEMBLY.)

05-17

AUTOMATIC TRANSAXLE

Reduction Planetary Gear

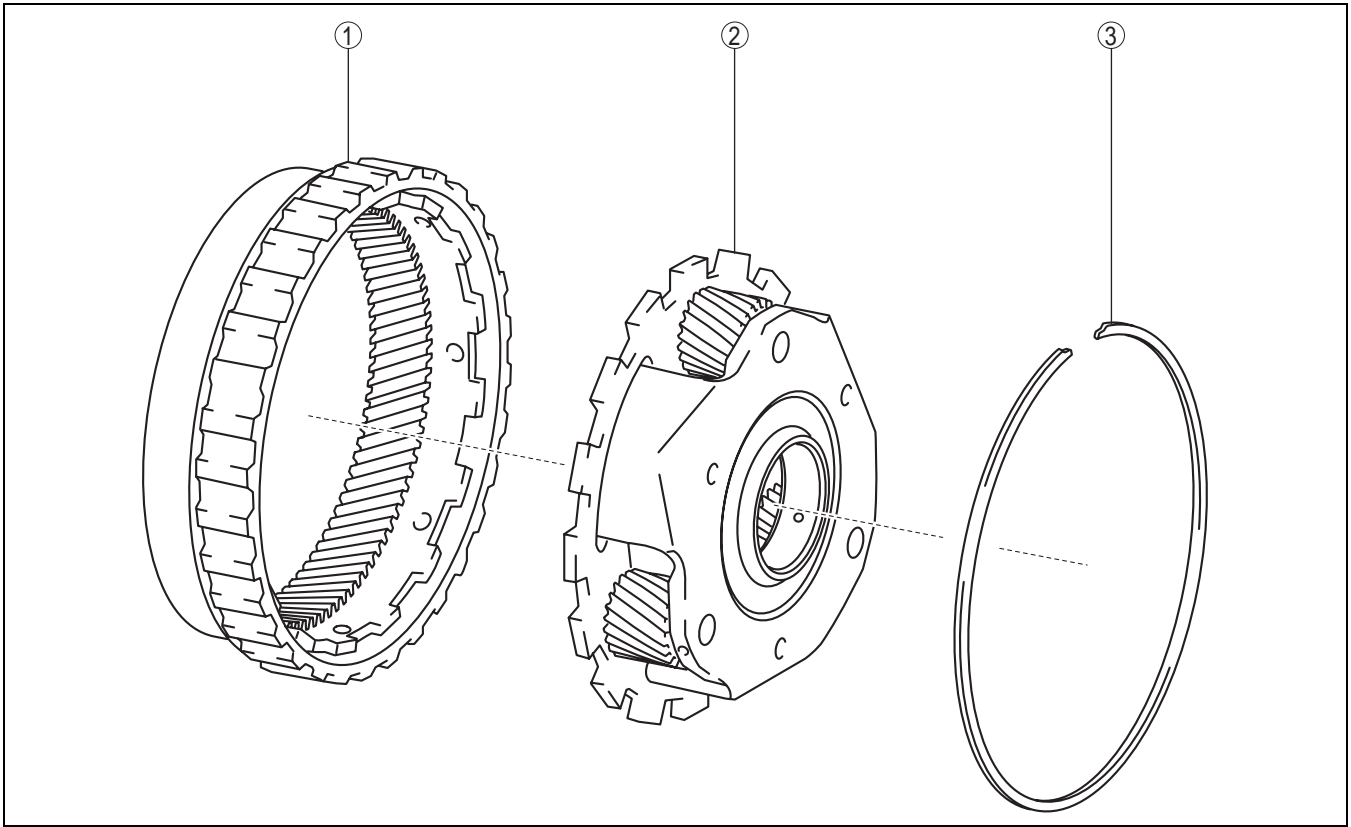

azzjiw00000297

1	Rear internal gear (See 05-17-136 REDUCTION PLANETARY GEAR DISASSEMBLY.) (See 05-17-261 REDUCTION PLANETARY GEAR ASSEMBLY.)
2	Reduction planetary carrier (See 05-17-136 REDUCTION PLANETARY GEAR DISASSEMBLY.) (See 05-17-261 REDUCTION PLANETARY GEAR ASSEMBLY.) (See 05-17-161 REDUCTION PLANETARY GEAR INSPECTION.)

3	Snap ring (See 05-17-136 REDUCTION PLANETARY GEAR DISASSEMBLY.) (See 05-17-261 REDUCTION PLANETARY GEAR ASSEMBLY.)
---	--

AUTOMATIC TRANSAXLE

Control Valve Body

05-17

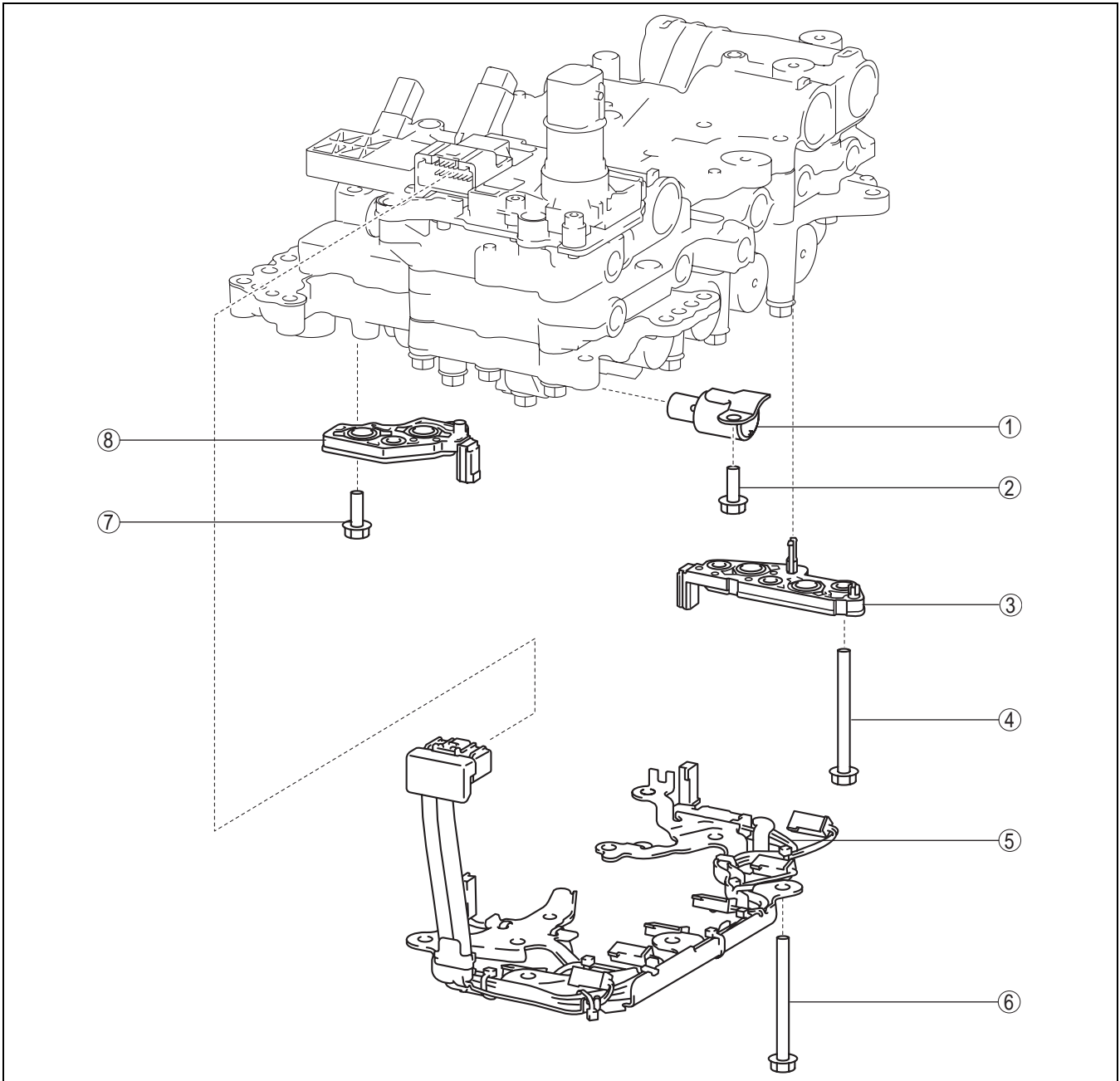

azzjjw00001437

1	ON/OFF solenoid (See 05-17-138 CONTROL VALVE BODY DISASSEMBLY.) (See 05-17-288 CONTROL VALVE BODY ASSEMBLY.)
2	Bolt (See 05-17-138 CONTROL VALVE BODY DISASSEMBLY.) (See 05-17-288 CONTROL VALVE BODY ASSEMBLY.)
3	Oil pressure switch A (See 05-17-138 CONTROL VALVE BODY DISASSEMBLY.) (See 05-17-288 CONTROL VALVE BODY ASSEMBLY.)

4	3 bolts (See 05-17-138 CONTROL VALVE BODY DISASSEMBLY.) (See 05-17-288 CONTROL VALVE BODY ASSEMBLY.)
5	Coupler component (See 05-17-138 CONTROL VALVE BODY DISASSEMBLY.) (See 05-17-288 CONTROL VALVE BODY ASSEMBLY.)
6	8 bolts (See 05-17-138 CONTROL VALVE BODY DISASSEMBLY.) (See 05-17-288 CONTROL VALVE BODY ASSEMBLY.)

AUTOMATIC TRANSAXLE

7	3 bolts (See 05-17-138 CONTROL VALVE BODY DISASSEMBLY.) (See 05-17-288 CONTROL VALVE BODY ASSEMBLY.)
---	--

8	Oil pressure switch B (See 05-17-138 CONTROL VALVE BODY DISASSEMBLY.) (See 05-17-288 CONTROL VALVE BODY ASSEMBLY.)
---	--

AUTOMATIC TRANSAXLE CLEANING

id051700660300

Cleaning Before Disassembly

1. Clean the outside of the transaxle using steam or degreaser before disassembly.

Caution

- If foreign matter, water, or degreaser penetrates the transaxle and connector, it could cause a malfunction. Before cleaning the outside of the transaxle, plug the position shown in the figure with the packing tape.

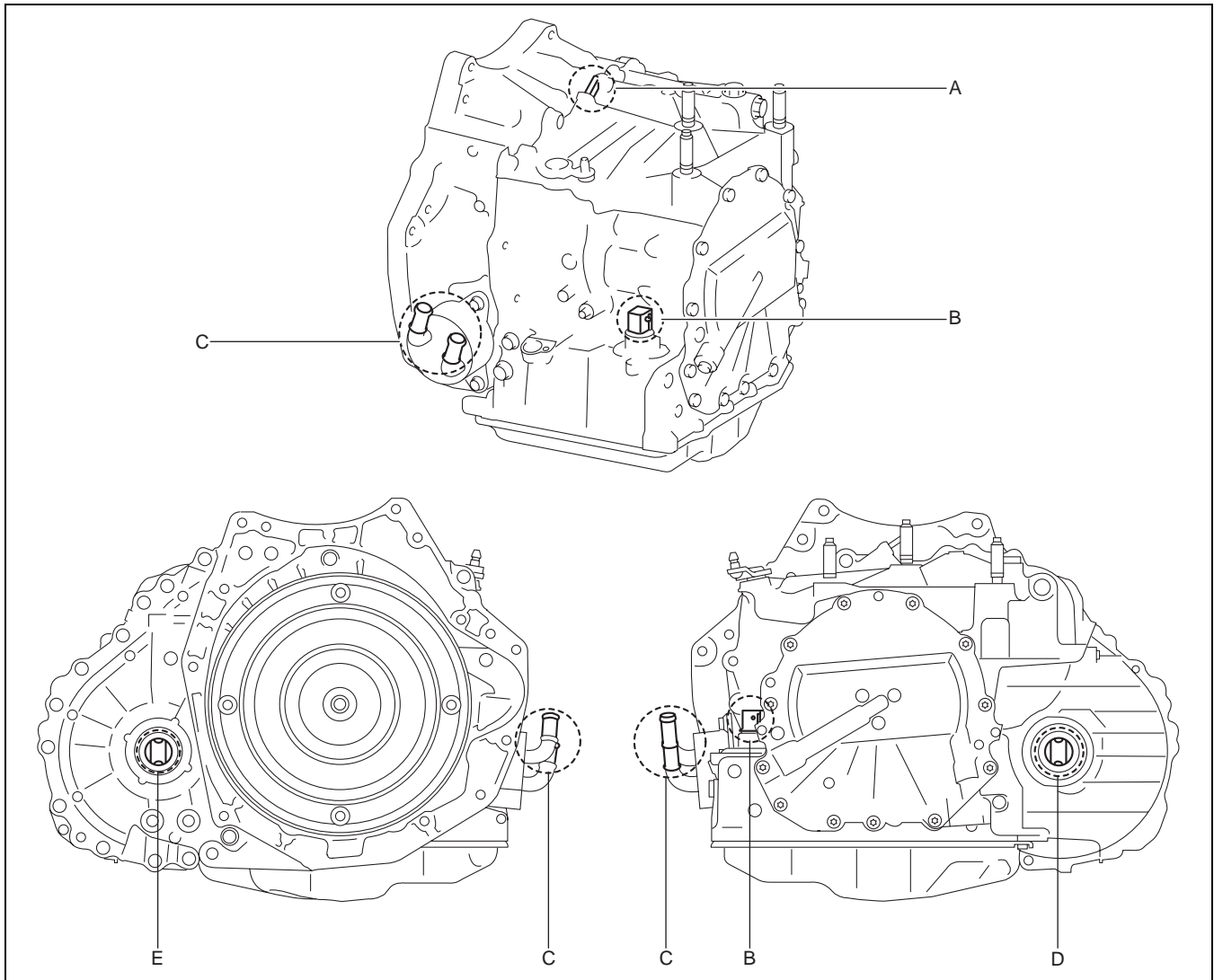

bfw1ua0000005

- A: Breather pipe
- B: Control valve body connector
- C: Oil cooler
- D: Oil seal
- E: Oil seal

2. Dry the outside of the transaxle with an air compressor.

Warning

- Always wear protective eye wear when using the air compressor. Otherwise, ATF or dirt particles blown off by the air compressor could get into the eyes.

Cleaning After Disassembly

Caution

- Do not clean the following parts, otherwise foreign matter or degreaser may penetrate the oil passage or internal part:
 - Control valve body (including the following parts:)
 - ON/OFF solenoid
 - Oil pressure switch A
 - Oil pressure switch B
 - Coupler component

1. Clean the torque converter. (See 05-17-145 TORQUE CONVERTER CLEANING.)

Caution

- To prevent damage to the parts, do not clean the inside of the torque converter using degreaser.

2. Clean the oil cooler. (See 05-17-147 OIL COOLER CLEANING.)

Caution

- To prevent damage to the parts, do not clean the inside of the oil cooler using degreaser.

3. Flush dirt on the surface of the drive plate with ATF (ATF FZ).

Caution

- To prevent damage to the parts, do not clean the drive plate using degreaser.

4. Clean the disassembled parts using degreaser and dry them using an air compressor. In addition, clean the oil passage using the air compressor.

Warning

- Always wear protective eye wear when using the air compressor. Otherwise, ATF or dirt particles blown off by the air compressor could get into the eyes.

Caution

- To prevent damage to parts, do not clean aluminum and rubber parts using alkaline agent.
- To prevent damage to parts, do not clean rubber parts using white gasoline and kerosene.

AUTOMATIC TRANSAXLE

Cleaning After Assembly

1. Remove the ATF or foreign matter adhering to the outside of the transaxle using degreaser or the air compressor.

Warning

- Always wear protective eye wear when using the air compressor. Otherwise, ATF or dirt particles blown off by the air compressor could get into the eyes.

Caution

- If foreign matter, water, or degreaser penetrates the transaxle and connector, it could cause a malfunction. Before cleaning the outside of the transaxle, plug the position shown in the figure with the packing tape.

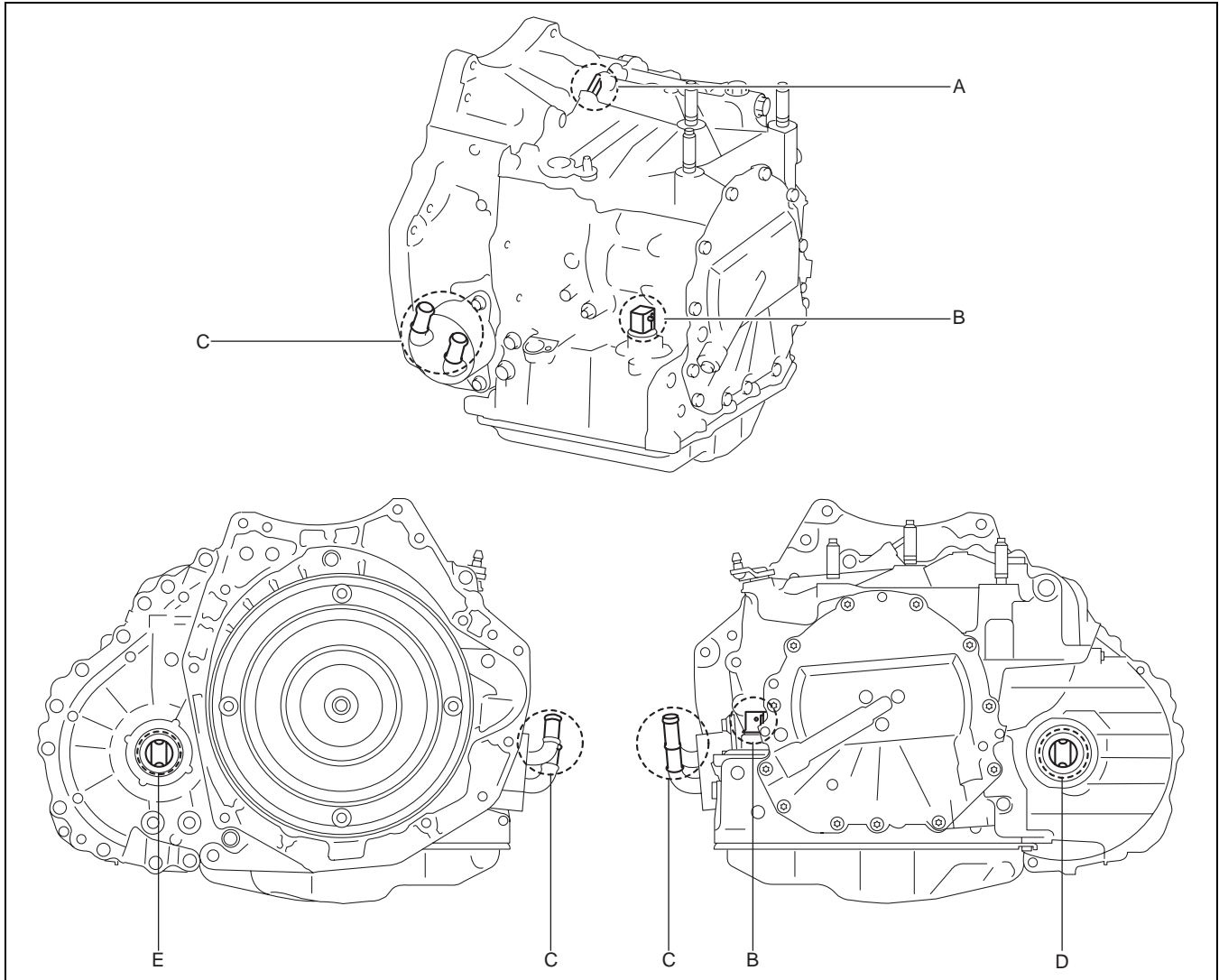

bfw1ua0000005

- A: Breather pipe
- B: Control valve body connector
- C: Oil cooler
- D: Oil seal
- E: Oil seal

AUTOMATIC TRANSAXLE

2. Verify that there is no ATF or foreign matter on the connector shown in the figure.

A : Control valve body connector

- If there is ATF or foreign matter on the connector shown in the figure, remove it.

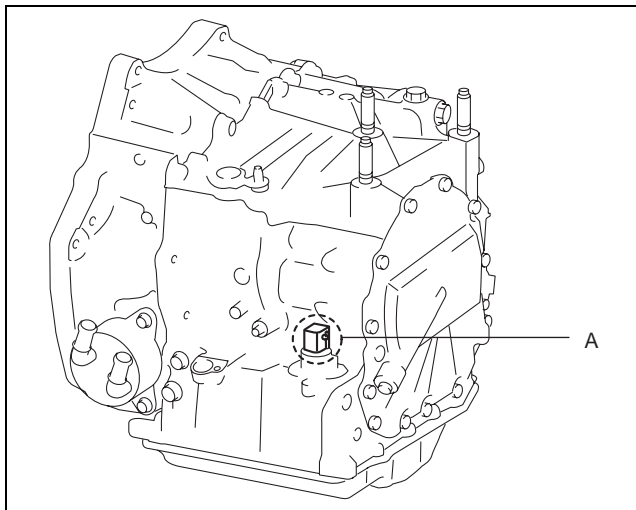

bfw1ua0000006

05-17

OIL SEAL (OIL PUMP) REPLACEMENT

id051700660400

Note

- Perform the following servicing only if the oil seal is replaced due to ATF leakage from the oil seal (oil pump).

1. Clean the outside of the transaxle. (See 05-17-26 AUTOMATIC TRANSAXLE CLEANING.)
2. Remove the stud bolts.

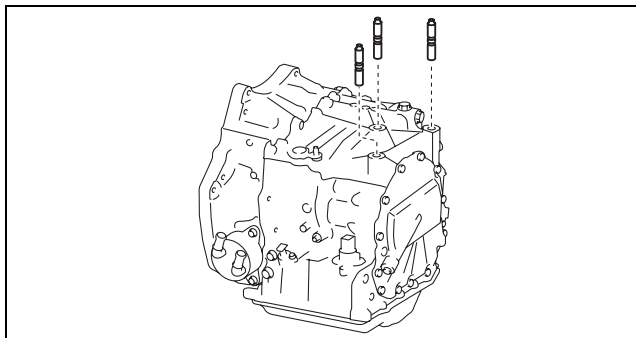

azzjjw00000304

3. Remove the torque converter.

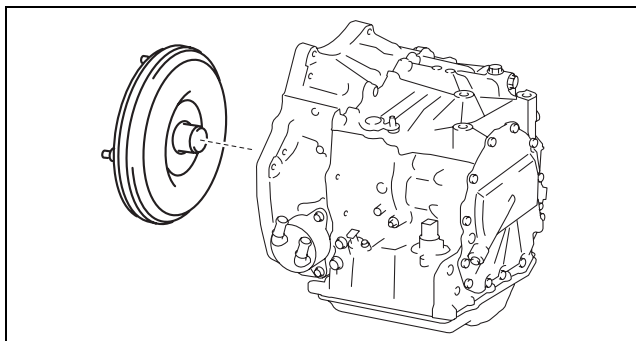

azzjjw00000305

AUTOMATIC TRANSAXLE

4. Install the transaxle to the SST (engine stand) using the following procedure:

Caution

- When installing the transaxle to the SST (engine stand) using chain hoists, be careful not to allow the transaxle (oil cooler in particular) to contact the SST (engine stand). If the transaxle contacts the SST, check the areas that made contact and replace damaged parts with new ones.

(1) Install the SSTs to the transaxle using the following procedure.

Note

- When installing the SST (49 L010 1A0) to the transaxle (stud bolt holes), use part number: 9YA02 1440 or M14×1.5 bolts, length to 100 mm {3.94 in}.
- When installing the SST (49 UN30 3050) to the transaxle, use part number: 9YA02 1015, or M10×1.5 bolts, length to 35 mm {1.4 in}.

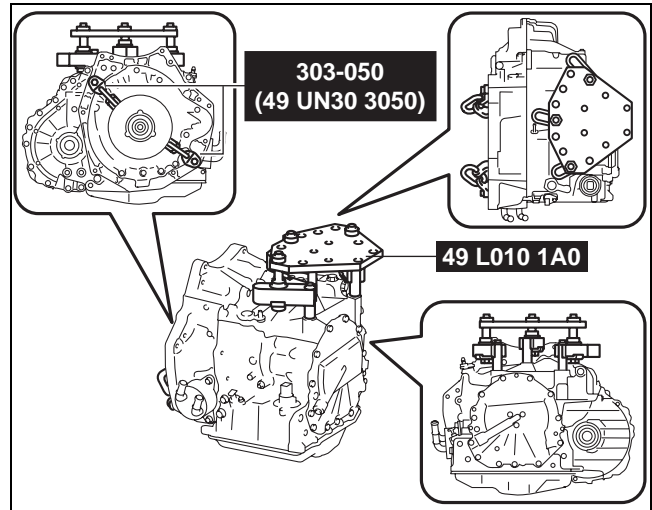

azzjiw00000306

- 1) Temporarily install the arms (49 L010 102) using part number: 9YA02 1440, or M14×1.5 bolts, length to 100 mm {3.94 in}.

A : Part number: 9YA02 1440, or M14×1.5 bolt, length to 100 mm {3.94 in}

Note

- To adjust the installation position of the SST in Step 3), temporarily tighten the bolts.

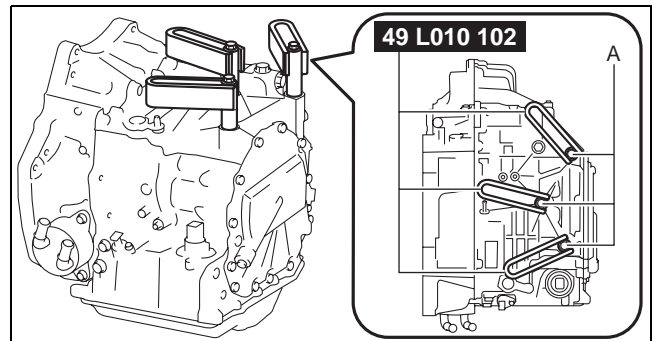

azzjiw00000307

- 2) Assemble the SST (49 L010 1A0).

A : Washer

B : Approx. 20 mm {0.79 in}

C : Approx. 26 mm {1.0 in}

D : Approx. 47 mm {1.9 in}

Note

- Use bolts (49 L010 105) with a length of 138 mm {5.43 in}.

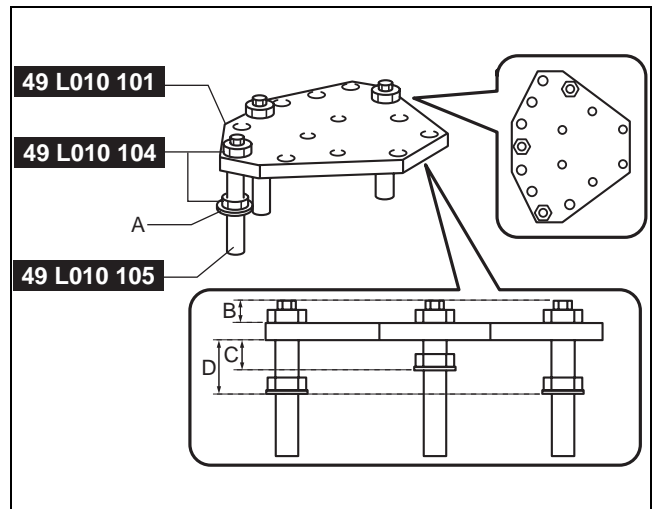

azzjiw00000308

AUTOMATIC TRANSAXLE

3) Install the SST assembled in Step 2).

A : Washer
B : Level out

Note

- Adjust so that the plate (49 L010 101) and arms (49 L010 102) are level, and install.

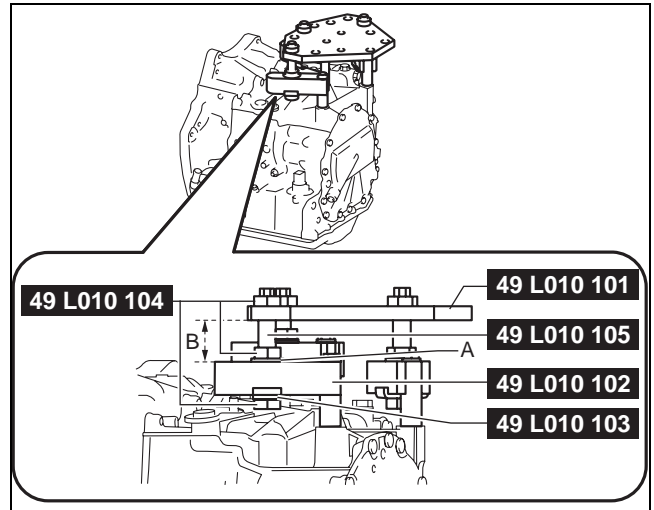

azzjw00000309

05-17

4) Verify that nothing other than the SST arms (49 L010 102) installation area contacts the transaxle.

Caution

- If something other than the SST arms (49 L010 102) installation area contacts the transaxle, readjust the SST to prevent damaging the part.

5) Tighten the nuts and bolts.

Tightening torque

- Bolt:** Part number: 9YA02 1440, or M14×1.5 bolt, length to 100 mm {3.94 in}
40—52 N·m {4.1—5.3 kgf·m, 30—38 ft·lbf}
- Nut:** 49 L010 104
140—160 N·m {15—16 kgf·m, 104—118 ft·lbf}

6) Assemble the SSTs using part number:
9YA02 1015, or M10×1.5 bolts, length to
35 mm {1.4 in}.

A : Part number: 9YA02 1015, or M10×1.5 bolt,
length to 35 mm {1.4 in}

Tightening torque

38—52 N·m {3.9—5.3 kgf·m, 29—38 ft·lbf}

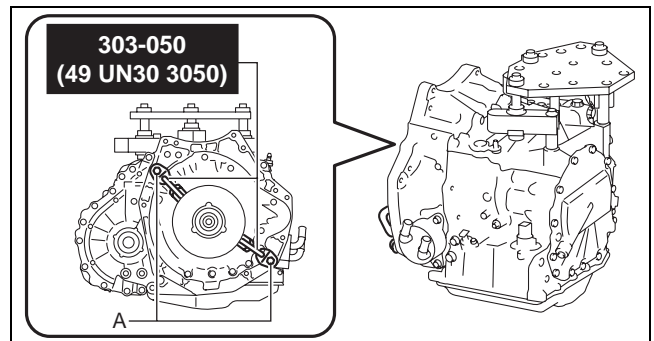

azzjw00000310

AUTOMATIC TRANSAXLE

(2) Using chain hoists, install the transaxle to the SST (engine stand) using part number: 9YA02 A220, or M12×1.75 bolts, length to 40 mm {1.6 in}.

A : Part number: 9YA02 A220, or M12×1.75 bolt, length to 40 mm {1.6 in}

Caution

- When installing the transaxle to the SST (engine stand) using chain hoists, be careful not to allow the transaxle (oil cooler in particular) to contact the SST (engine stand). If the transaxle contacts the SST, check the areas that made contact and replace damaged parts with new ones.

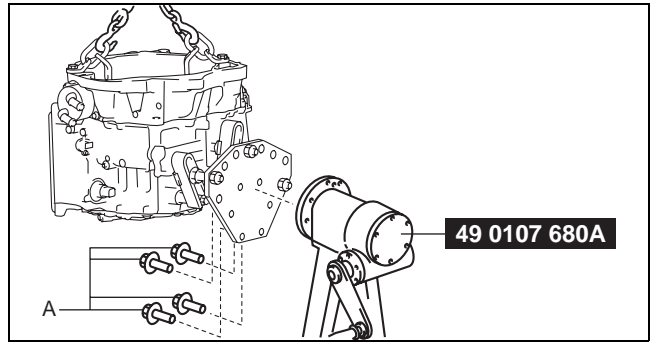

azzjiw00000311

Note

- Tighten the four locations with bolts and securely install the transaxle to the SST (engine stand).

Tightening torque

88—118 N·m {9.0—12 kgf·m, 65—87 ft·lbf}

(3) Remove the SSTs.

A : Part number: 9YA02 1015, or M10×1.5 bolt, length to 35 mm {1.4 in}

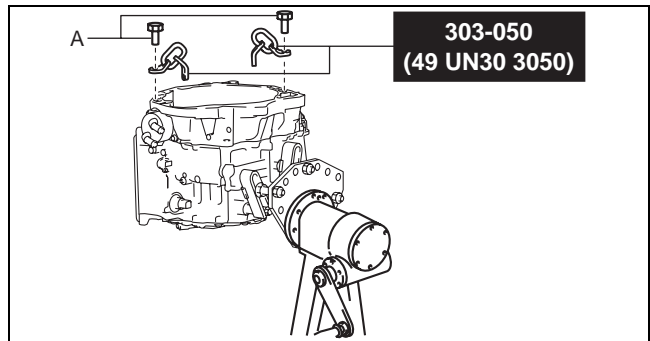

azzjiw00000312

5. Remove the converter housing using the following procedure:

1	24 bolts
2	Converter housing
3	O-ring (oil pump)
4	O-ring (oil cooler oil passage)

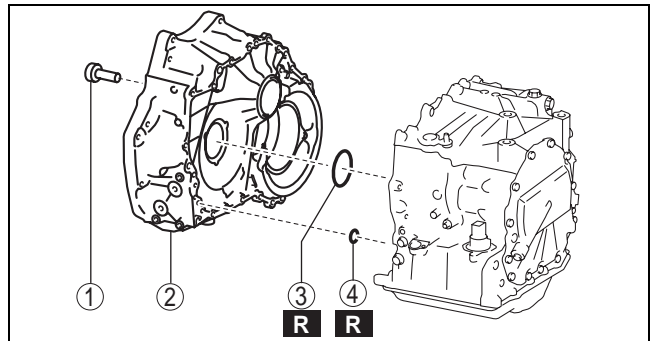

azzjiw00000313

(1) Remove the bolts shown in the figure.

Caution

- Sealant has been applied to the removed bolts. If the bolts are reused it could cause ATF leakage, therefore when performing assembly use new bolts.

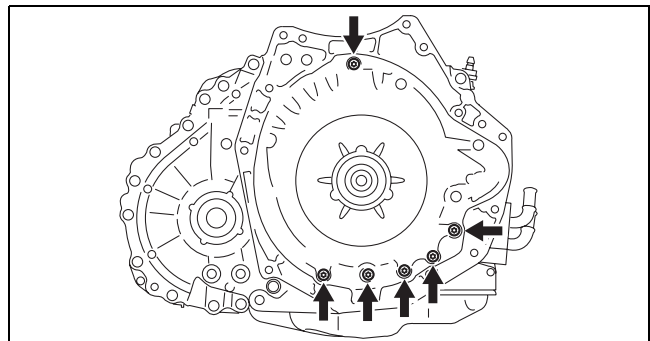

azzjiw00000314

AUTOMATIC TRANSAXLE

(2) Remove the bolts shown in the figure.

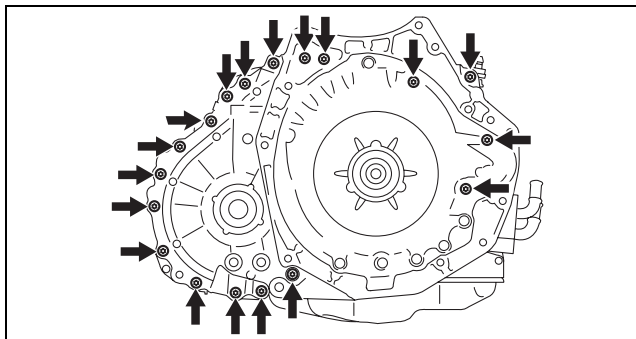

azzjw00000315

05-17

(3) Lightly tap the converter housing using a plastic hammer to remove it.

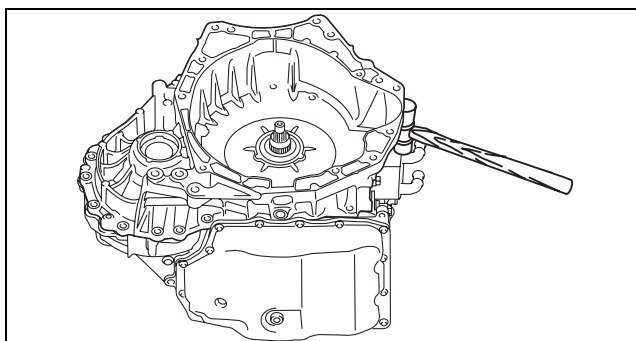

azzjw00000316

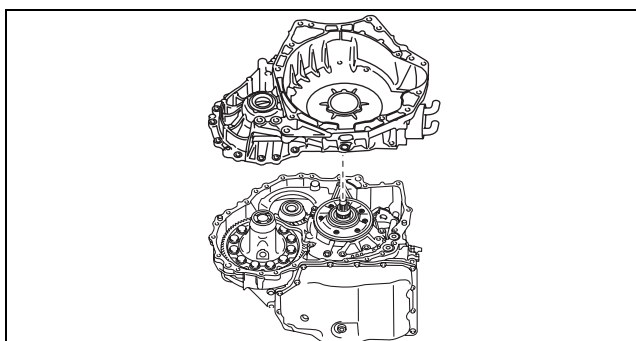

azzjw00000317

(4) Remove the O-rings.

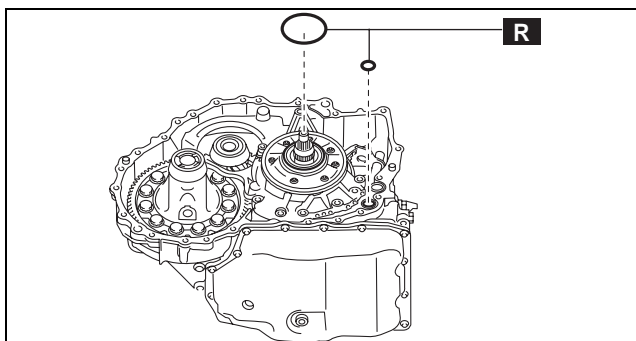

azzjw00000318

AUTOMATIC TRANSAXLE

6. Remove the oil seal using the following procedure:

1	7 bolts
2	Oil pump cover
3	Oil seal

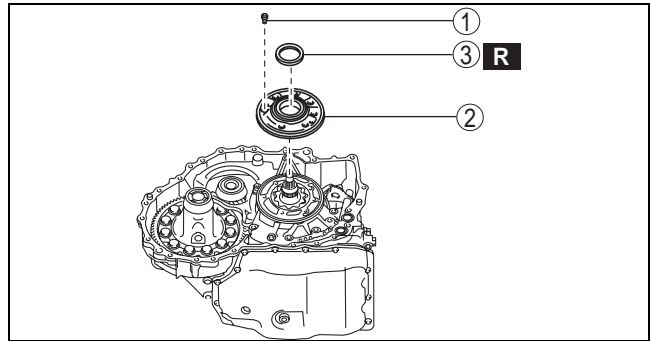

azzjiw00000319

(1) Remove the bolts shown in the figure.

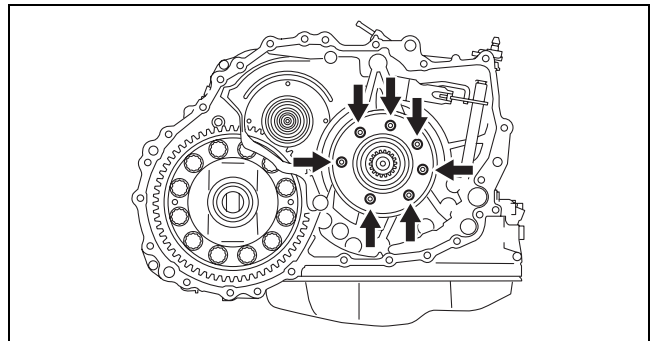

azzjiw00000320

(2) Remove the oil pump cover.

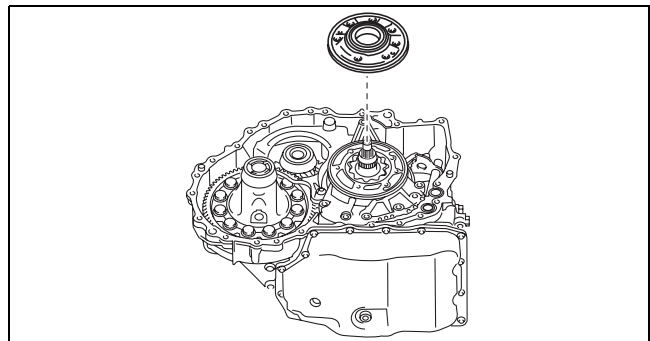

azzjiw00000321

(3) Remove the oil seal.

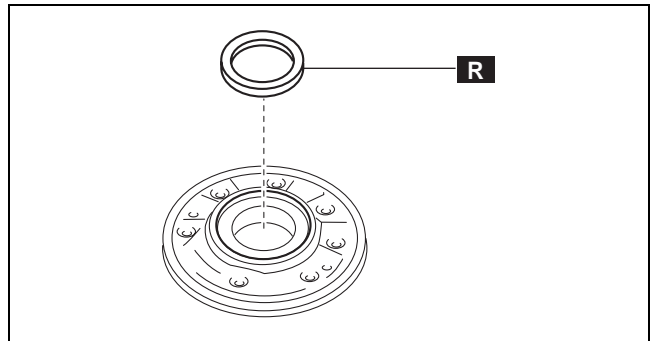

azzjiw00000322

7. Assemble a new oil seal using the following procedure:

1	Oil seal
2	Oil pump cover
3	7 bolts (M6×1.0 bolt, length to approx. 13 mm {0.51 in})

Caution

- If an oil seal is reused it could cause ATF leakage, therefore use a new oil seal.

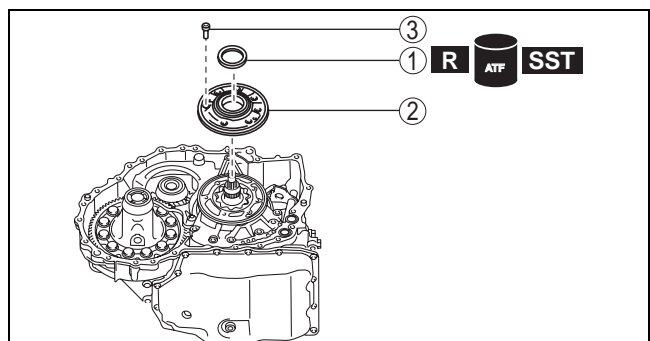

azzjiw00001412

AUTOMATIC TRANSAXLE

- (1) Apply ATF (ATF FZ) to the engagement area of the new oil seal and oil pump cover.
- (2) Apply ATF (ATF FZ) to the lip of the new oil seal.
- (3) Assemble the new oil seal to the position shown in the figure using the SST.

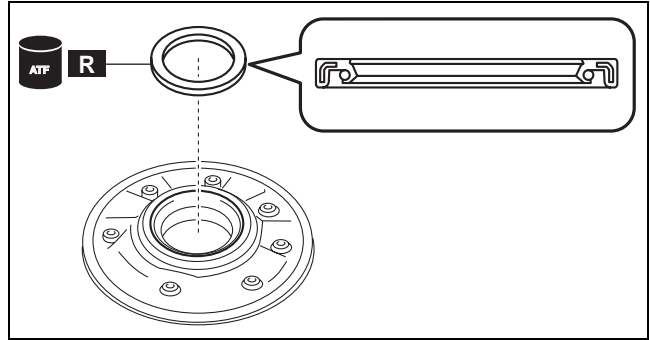

azzjjw00000324

A : 0—0.5 mm {0—0.01 in}

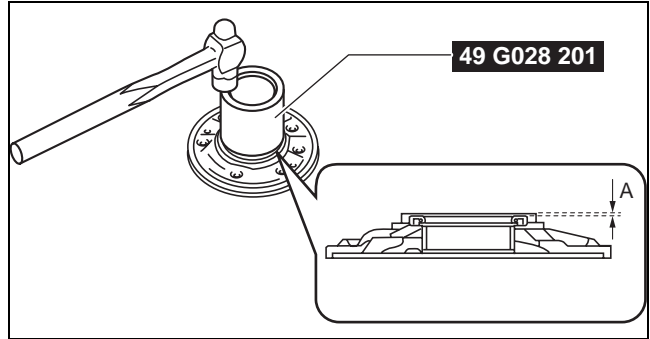

azzjjw00000325

- (4) Assemble the oil pump cover.

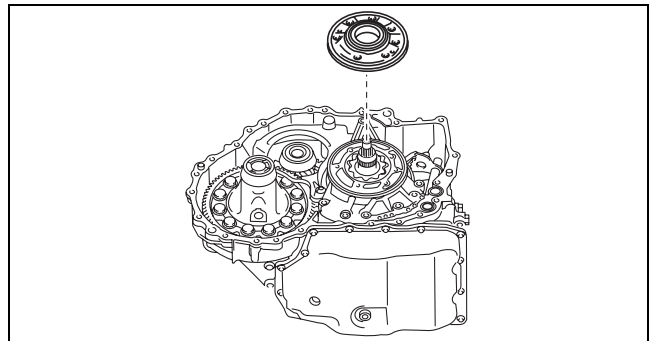

azzjjw00000321

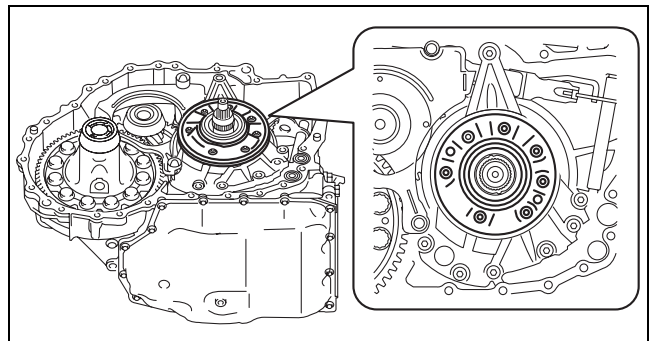

azzjjw00000326

05-17

AUTOMATIC TRANSAXLE

(5) Assemble and tighten the bolts shown in the figure.

Note

- Bolt size: M6×1.0 bolt, length to approx. 13 mm {0.51 in}

Tightening torque

9—10 N·m {92—101 kgf·cm, 80—88 in·lbf}

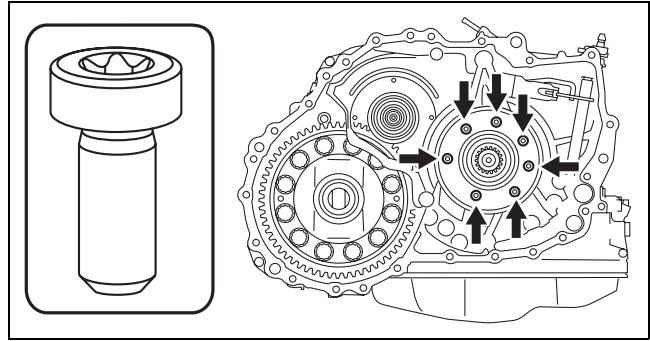

azzjiw00000327

8. Assemble the converter housing using the following procedure:

1	O-ring (outer diameter approx. 15.6 mm {0.614 in}, thickness approx. 2.4 mm {0.094 in})
2	O-ring (outer diameter approx. 73.3 mm {2.89 in}, thickness approx. 3.0 mm {0.12 in})
3	Converter housing
4	24 bolts * (M8×1.25 bolt, length to approx. 28 mm {1.1 in})

* : Of the 24 bolts, 6 are applied with sealant

(1) Assemble new O-rings using the following procedure:

Caution

- If an O-ring is reused it could cause ATF leakage, therefore use a new O-ring.

- 1) Apply ATF (ATF FZ) to the new O-rings.
- 2) Assemble the new O-rings.

1	O-ring (outer diameter approx. 15.6 mm {0.614 in}, thickness approx. 2.4 mm {0.094 in})
2	O-ring (outer diameter approx. 73.3 mm {2.89 in}, thickness approx. 3.0 mm {0.12 in})

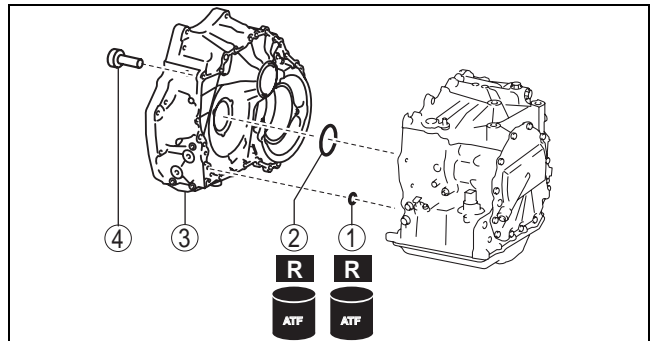

azzjiw00000328

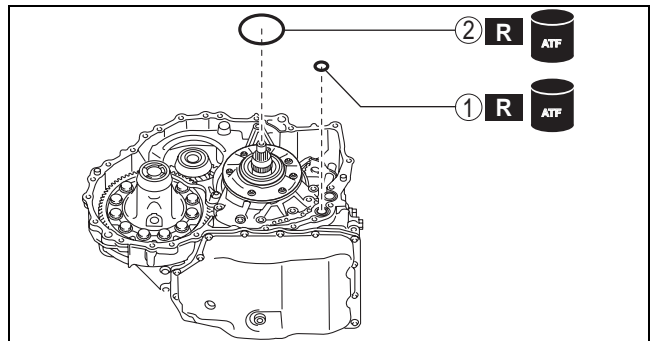

azzjiw00000329

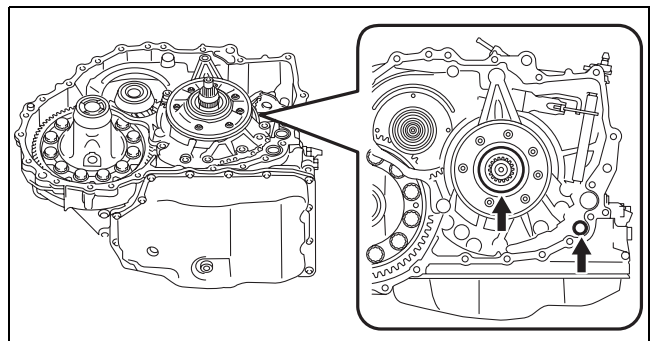

azzjiw00000330

AUTOMATIC TRANSAXLE

- (2) Remove any remaining old sealant on the contact surfaces of the transaxle case and converter housing, and degrease the contact surfaces.

Caution

- When degreasing and if degreaser is used, use a rag saturated with degreaser and be careful not to allow degreaser to penetrate the interior of the transaxle. In addition, after degreasing, visually verify that there is no foreign matter (such as old sealant, cloth fibers) which has penetrated the interior of the transaxle.

- (3) Apply sealant (silicone sealant TB1217E) to the transaxle case.

Caution

- If sealant is applied excessively or applied to a part other than the indicated part, the O-ring could deform and the sealant could penetrate the oil passage. Apply an appropriate amount of sealant to the indicated part.

Note

- Sealant application amount (bead thickness): ϕ 1.8—2.5 mm {0.071—0.098 in}

- (4) Assemble the converter housing before the applied sealant starts to harden.

- (5) Assemble and temporarily tighten the bolts to the positions shown in the figure.

Note

- Bolt size: M8×1.25 bolt, length to approx. 28 mm {1.1 in}

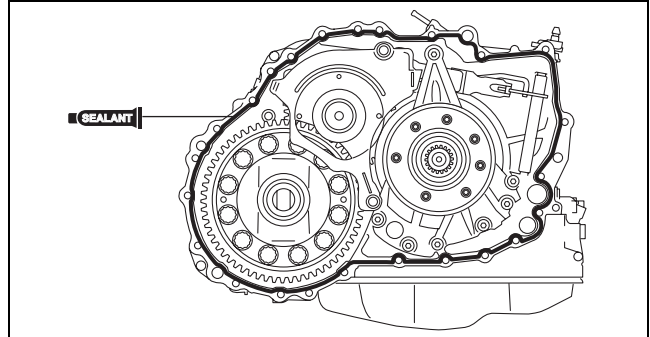

azzjw00000331

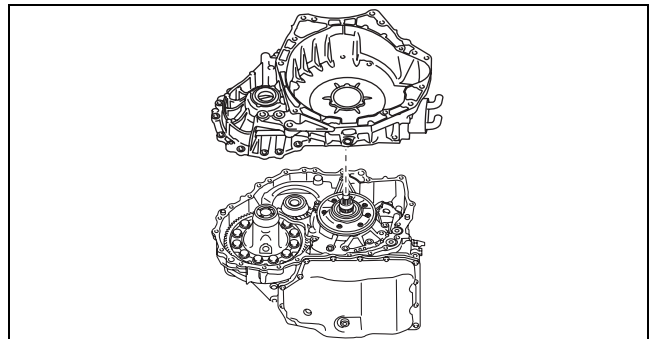

azzjw00000317

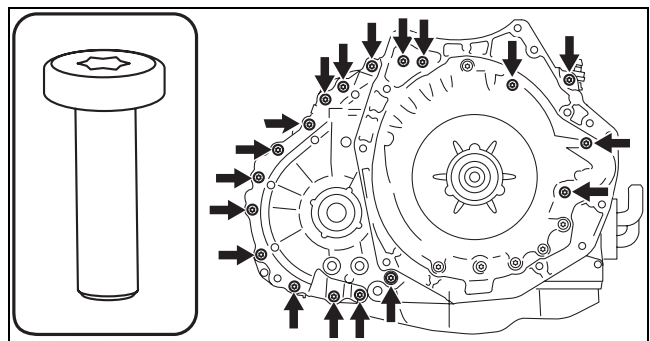

azzjw00000332

AUTOMATIC TRANSAXLE

- (6) Assemble and temporarily tighten the new bolts to the positions shown in the figure.

Caution

- The bolts for the assembly are applied with sealant. If the bolts are reused it could cause ATF leakage, therefore use new bolts.

Note

- Bolt size: M8×1.25 bolt, length to approx. 28 mm {1.1 in} (with sealant applied)

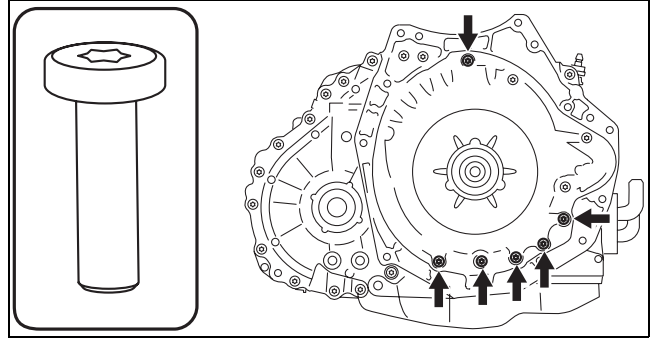

azzjw00000333

- (7) Tighten the bolts shown in the figure.

Tightening torque

19—25 N·m {2.0—2.5 kgf·m, 15—18 ft·lbf}

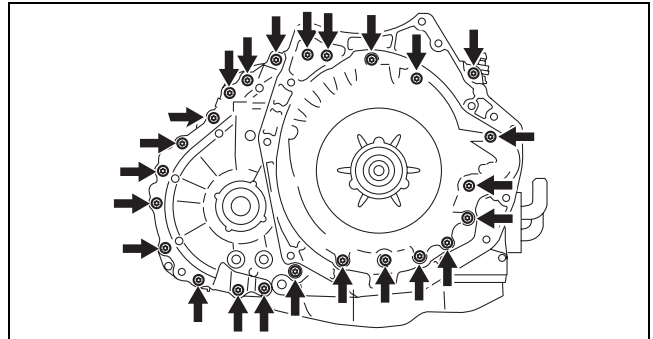

azzjw00000334

9. Remove the SSTs from the transaxle using the following procedure:

Caution

- When removing the transaxle from the SST (engine stand) using chain hoists, be careful not to allow the transaxle (oil cooler in particular) to contact the SST (engine stand). If the transaxle contacts the SST, check the areas that made contact and replace damaged parts with new ones.

- (1) Assemble the SSTs using part number: 9YA02 1015, or M10×1.5 bolts, length to 35 mm {1.4 in}.

A : Part number: 9YA02 1015, or M10×1.5 bolt, length to 35 mm {1.4 in}

Tightening torque

38—52 N·m {3.9—5.3 kgf·m, 29—38 ft·lbf}

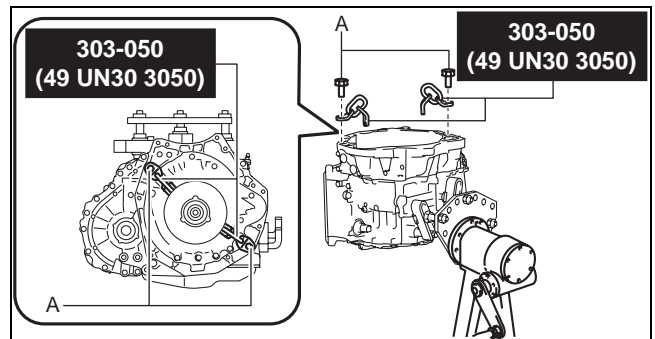

azzjw00000335

- (2) Using chain hoists, remove the SST (engine stand) from the transaxle.

A : Part number: 9YA02 A220, or M12×1.75 bolt, length to 40 mm {1.6 in}

Caution

- When removing the transaxle from the SST (engine stand) using chain hoists, be careful not to allow the transaxle (oil cooler in particular) to contact the SST (engine stand). If the transaxle contacts the SST, check the areas that made contact and replace damaged parts with new ones.

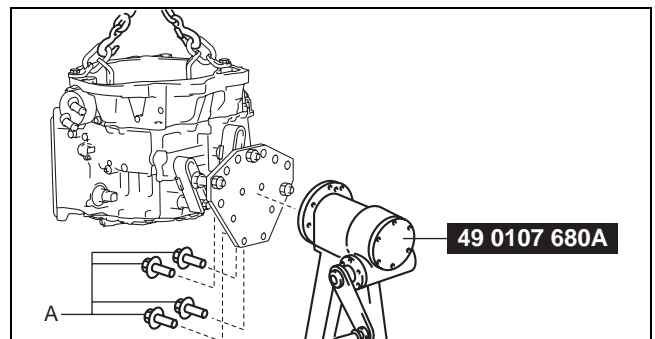

azzjw00000311

AUTOMATIC TRANSAXLE

(3) Remove the SSTs.

A : Part number: 9YA02 1015, or M10×1.5 bolt, length to 35 mm {1.4 in}

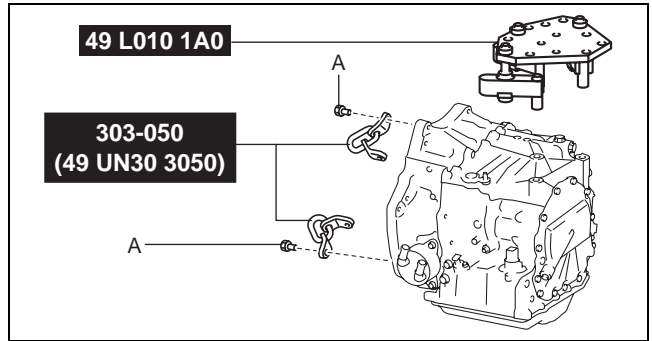

05-17

(4) Disassemble the SST.

A : Part number: 9YA02 1440, or M14×1.5 bolt, length to 100 mm {3.94 in}

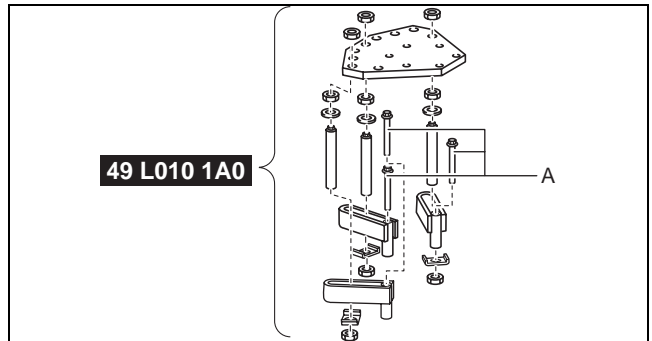

10. Assemble the torque converter using the following procedure:

(1) Apply ATF (ATF FZ) to the end of the starter shaft of the oil pump shown in the figure.

Caution

- Accurately perform to protect the torque converter internal parts.

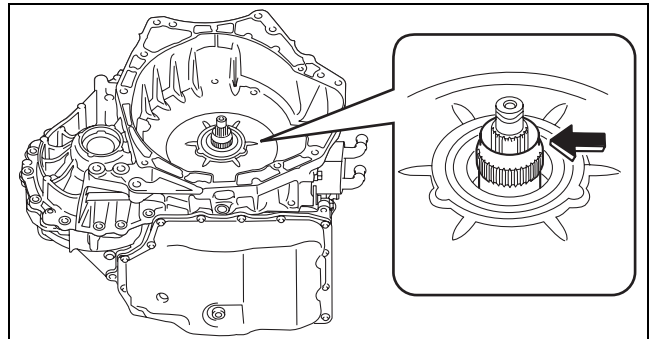

(2) Assemble the torque converter so that the two surfaces of the notch on the end of the torque converter engage the inner rotor of the oil pump.

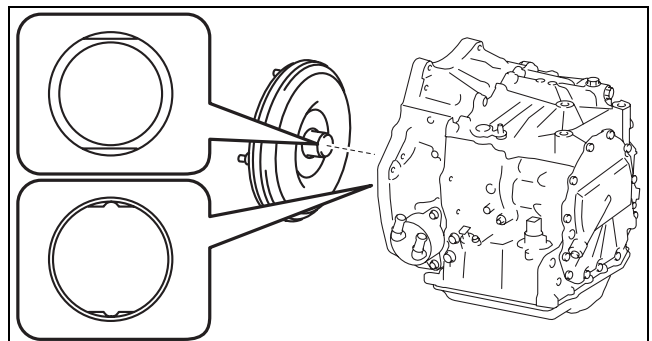

AUTOMATIC TRANSAXLE

(3) To verify that the torque converter is securely assembled, measure the distance shown in the figure.

A : Converter housing end (alignment surface with engine)

B : Torque converter stud bolt seat

Note

- Recommended measuring instrument:
Depth gauge, straight edge ruler

Specification

14.6 mm {0.575 in} or more

- If not within the specification, remove the torque converter and reassemble.

Note

- Measurement method

- 1) Set two straight edge rulers along the alignment surface of the converter housing with the engine as shown in the figure.

A : Straight edge ruler

- 2) Measure the positions (2 locations) shown in the figure using a depth gauge and calculate the average value.
- 3) Subtract the thickness of the straight edge ruler from the average value.

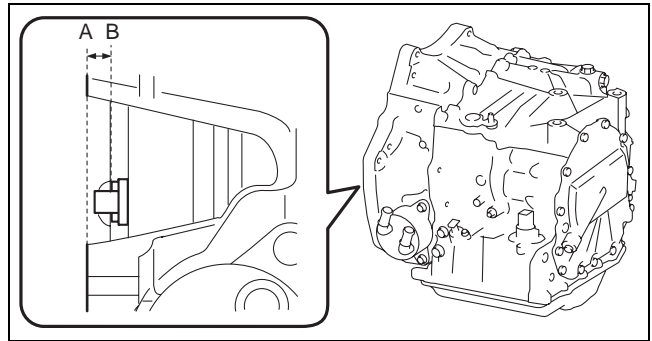

azzjiw00001417

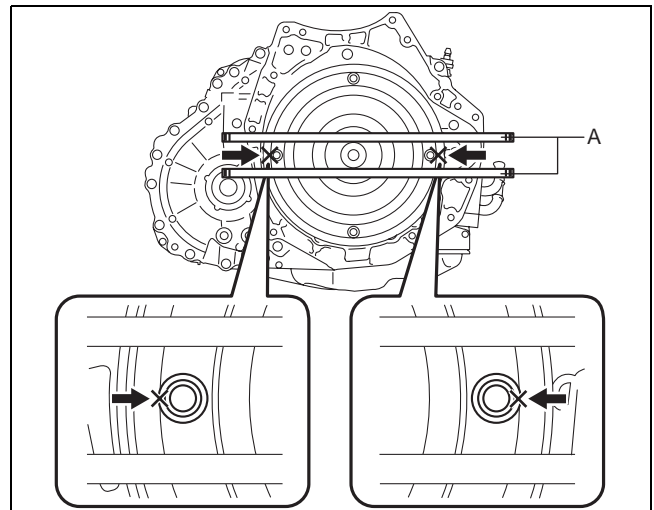

azzjiw00000340

11. Assemble and tighten the stud bolts.

Tightening torque

15—25 N·m {1.6—2.5 kgf·m, 12—18 ft·lbf}

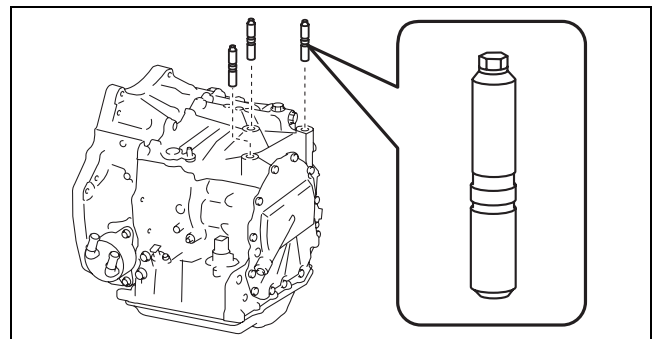

azzjiw00000341

AUTOMATIC TRANSAXLE

OIL SEAL (PARKING SHIFT LEVER) REPLACEMENT

id051700660500

Note

- Perform the following servicing only if the oil seal is replaced due to ATF leakage from the oil seal (parking shift lever).

1. Clean the outside of the transaxle. (See 05-17-26 AUTOMATIC TRANSAXLE CLEANING.)
2. Remove the stud bolts.

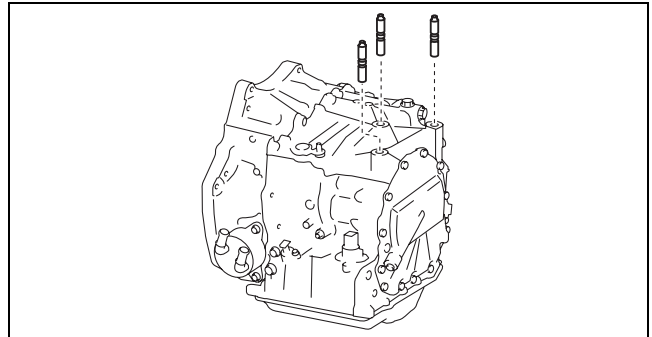

azzjw00000304

3. Remove the torque converter.

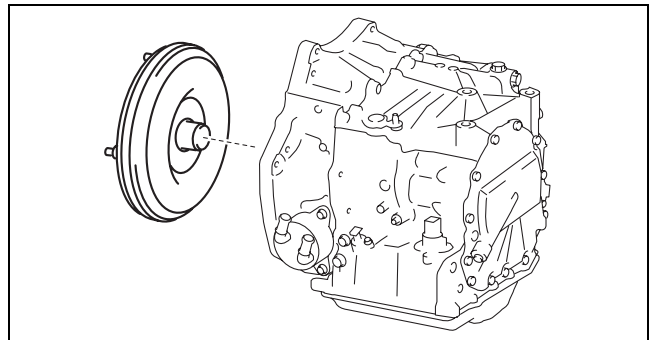

azzjw00000305

4. Install the transaxle to the SST (engine stand) using the following procedure:

Caution

- When installing the transaxle to the SST (engine stand) using chain hoists, be careful not to allow the transaxle (oil cooler in particular) to contact the SST (engine stand). If the transaxle contacts the SST, check the areas that made contact and replace damaged parts with new ones.

- (1) Install the SSTs to the transaxle using the following procedure.

Note

- When installing the SST (49 L010 1A0) to the transaxle (stud bolt holes), use part number: 9YA02 1440 or M14×1.5 bolts, length to 100 mm {3.94 in}.
- When installing the SST (49 UN30 3050) to the transaxle, use part number: 9YA02 1015, or M10×1.5 bolts, length to 35 mm {1.4 in}.

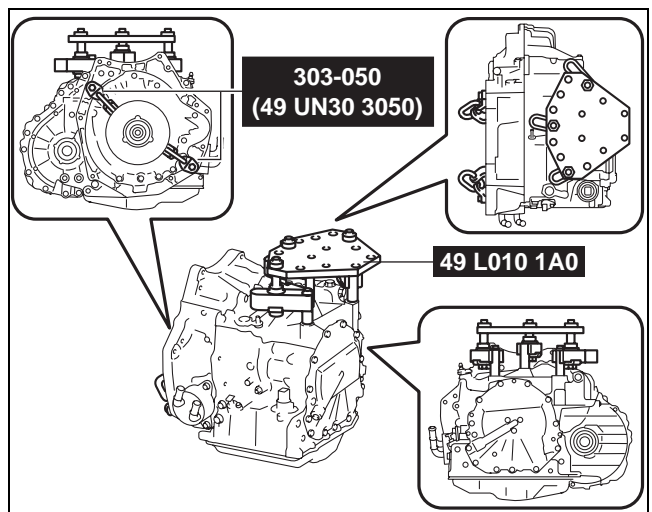

azzjw00000306

05-17

AUTOMATIC TRANSAXLE

- 1) Temporarily install the arms (49 L010 102) using part number: 9YA02 1440, or M14×1.5 bolts, length to 100 mm {3.94 in}.

A : Part number: 9YA02 1440, or M14×1.5 bolt, length to 100 mm {3.94 in}

Note

- To adjust the installation position of the SST in Step 3), temporarily tighten the bolts.

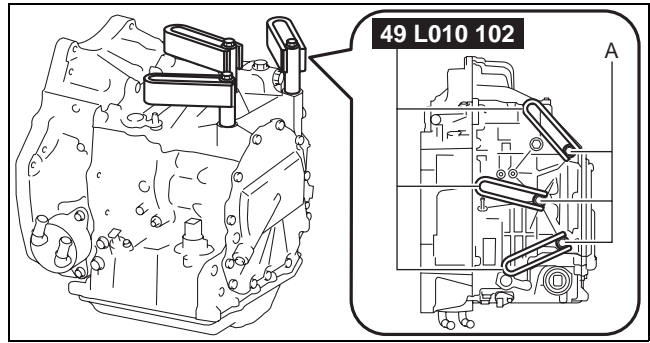

azzjiw00000307

- 2) Assemble the SST (49 L010 1A0).

A : Washer

B : Approx. 20 mm {0.79 in}

C : Approx. 26 mm {1.0 in}

D : Approx. 47 mm {1.9 in}

Note

- Use bolts (49 L010 105) with a length of 138 mm {5.43 in}.

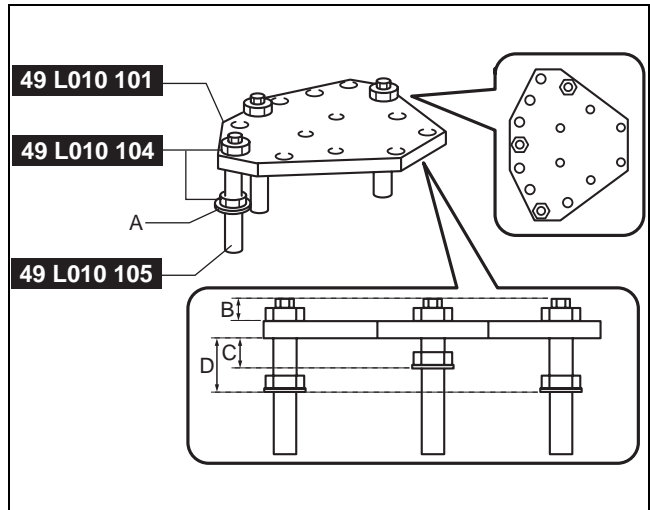

azzjiw00000308

- 3) Install the SST assembled in Step 2).

A : Washer

B : Level out

Note

- Adjust so that the plate (49 L010 101) and arms (49 L010 102) are level, and install.

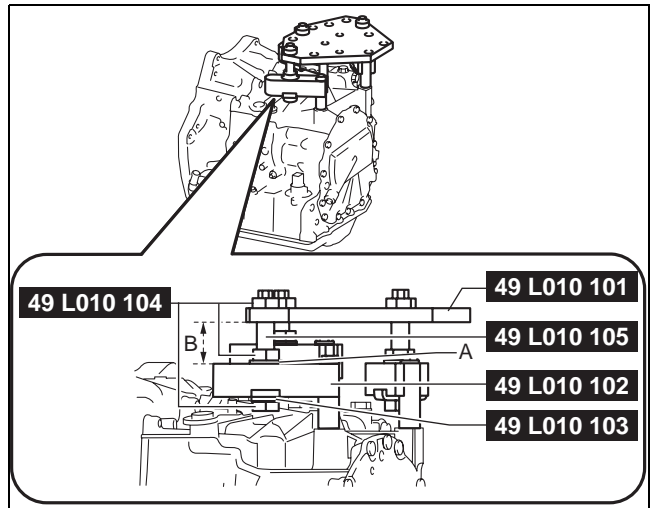

azzjiw00000309

- 4) Verify that nothing other than the SST arms (49 L010 102) installation area contacts the transaxle.

Caution

- If something other than the SST arms (49 L010 102) installation area contacts the transaxle, readjust the SST to prevent damaging the part.

AUTOMATIC TRANSAXLE

5) Tighten the nuts and bolts.

Tightening torque

- Bolt: Part number: 9YA02 1440, or M14×1.5 bolt, length to 100 mm {3.94 in}
40—52 N·m {4.1—5.3 kgf·m, 30—38 ft·lbf}
- Nut: 49 L010 104
140—160 N·m {15—16 kgf·m, 104—118 ft·lbf}

6) Assemble the SSTs using part number:
9YA02 1015, or M10×1.5 bolts, length to
35 mm {1.4 in}.

A : Part number: 9YA02 1015, or M10×1.5 bolt,
length to 35 mm {1.4 in}

Tightening torque

38—52 N·m {3.9—5.3 kgf·m, 29—38 ft·lbf}

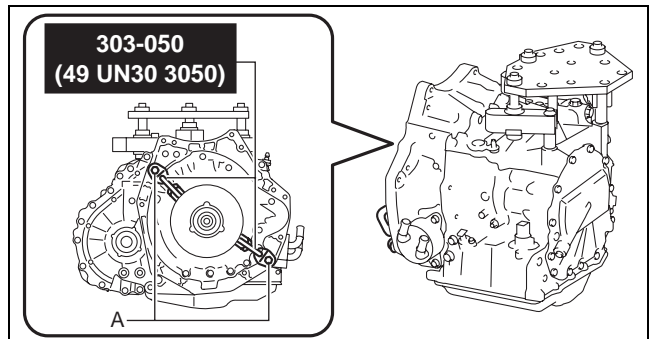

azzjjw00000310

(2) Using chain hoists, install the transaxle to the
SST (engine stand) using part number:
9YA02 A220, or M12×1.75 bolts, length to 40
mm {1.6 in}.

A : Part number: 9YA02 A220, or M12×1.75 bolt,
length to 40 mm {1.6 in}

Caution

- When installing the transaxle to the SST (engine stand) using chain hoists, be careful not to allow the transaxle (oil cooler in particular) to contact the SST (engine stand). If the transaxle contacts the SST, check the areas that made contact and replace damaged parts with new ones.

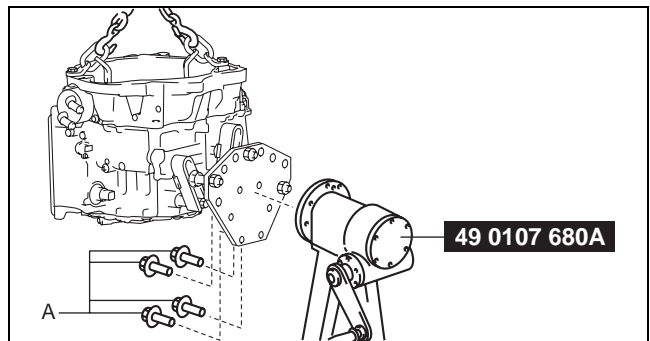

azzjjw00000311

Note

- Tighten the four locations with bolts and securely install the transaxle to the SST (engine stand).

Tightening torque

88—118 N·m {9.0—12 kgf·m, 65—87 ft·lbf}

(3) Remove the SSTs.

A : Part number: 9YA02 1015, or M10×1.5 bolt,
length to 35 mm {1.4 in}

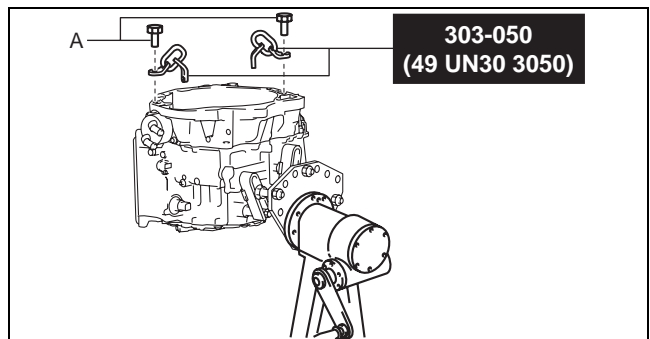

azzjjw00000312

AUTOMATIC TRANSAXLE

5. Remove the converter housing using the following procedure:

1	24 bolts
2	Converter housing
3	O-ring (oil pump)
4	O-ring (oil cooler oil passage)

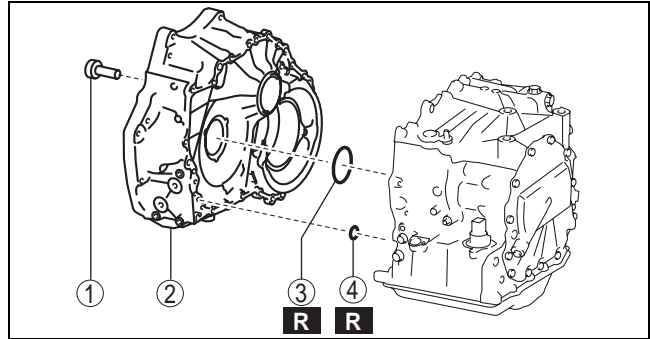

azzjw00000313

(1) Remove the bolts shown in the figure.

Caution

- Sealant has been applied to the removed bolts. If the bolts are reused it could cause ATF leakage, therefore when performing assembly use new bolts.

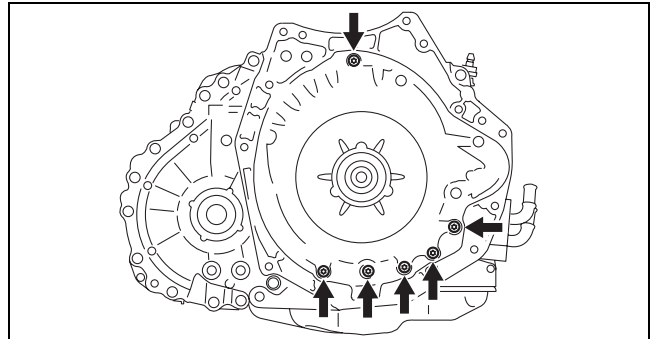

azzjw00000314

(2) Remove the bolts shown in the figure.

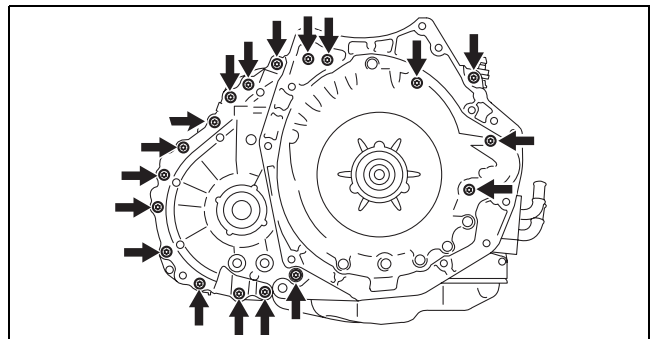

azzjw00000315

(3) Lightly tap the converter housing using a plastic hammer to remove it.

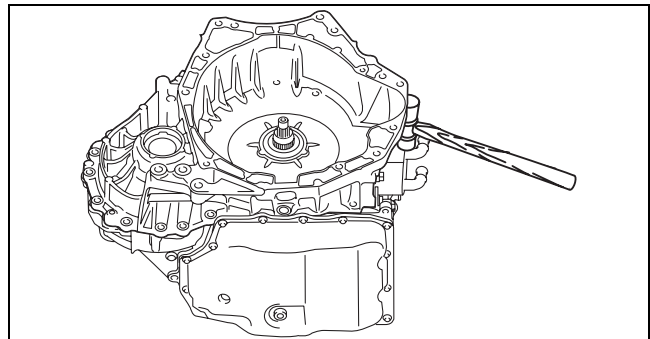

azzjw00000316

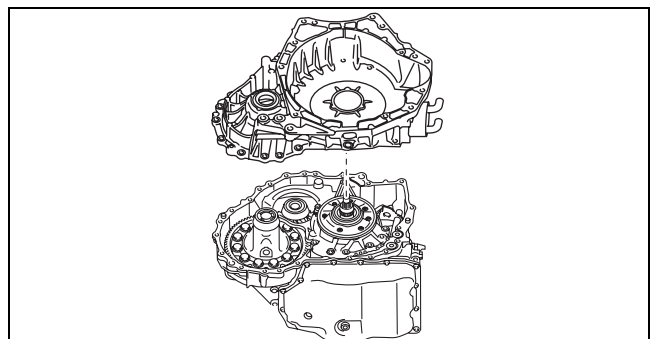

azzjw00000317

AUTOMATIC TRANSAXLE

(4) Remove the O-rings.

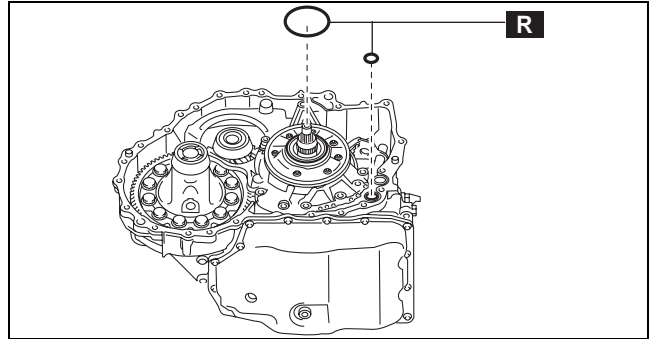

azzjjw00000318

05-17

6. Remove the baffle plate.

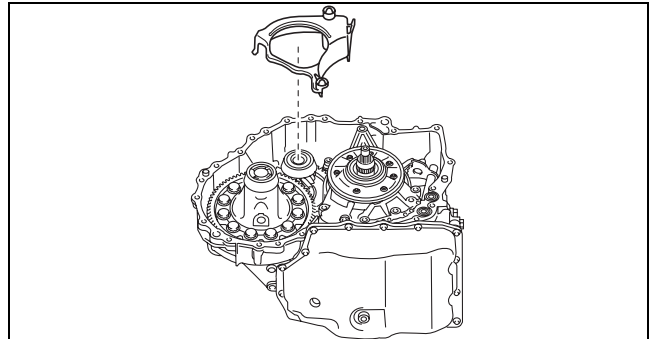

azzjjw00000347

7. Remove the oil pump using the following procedure:

1	7 bolts
2	Oil pump

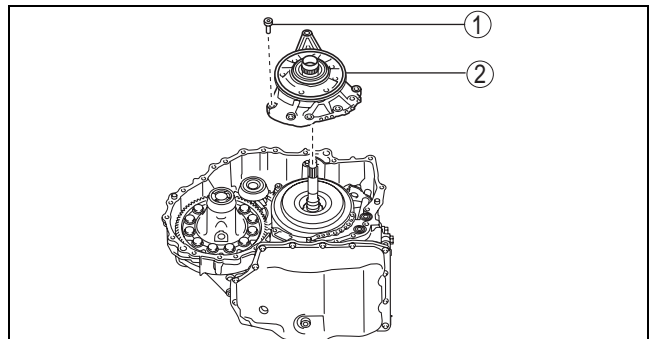

azzjjw00000348

(1) Remove the bolts shown in the figure.

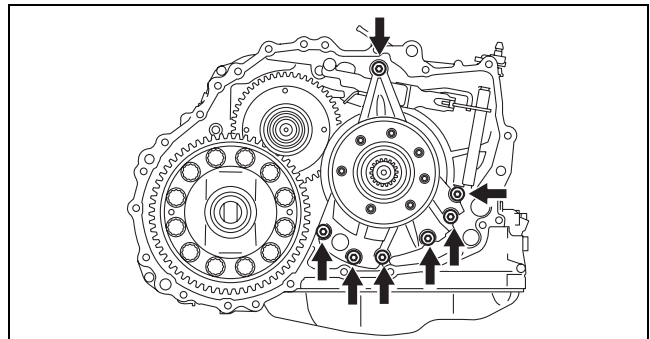

azzjjw00000349

AUTOMATIC TRANSAXLE

(2) Remove the oil pump.

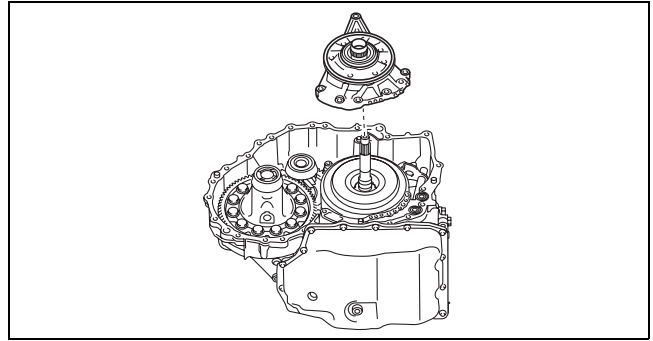

azzjw00000350

8. Remove the thrust needle bearing.

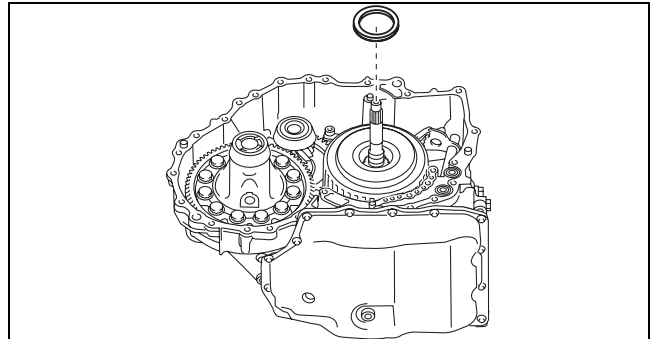

azzjw00000351

9. Remove the clutch component.

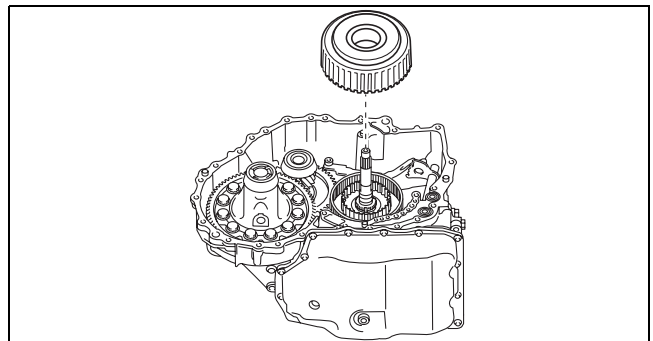

azzjw00000352

10. Remove the turbine shaft.

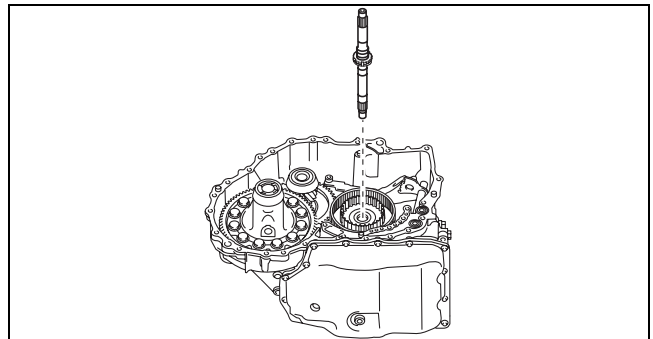

azzjw00000353

AUTOMATIC TRANSAXLE

11. Remove the D-ring and seal rings from the turbine shaft using the procedure in the figure:

1	D-ring
2	Seal ring

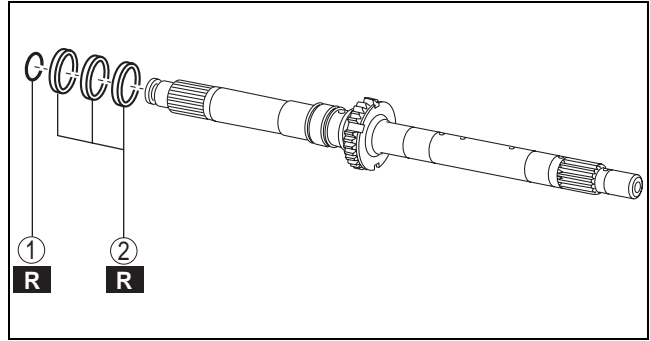

azzjjw00000354

05-17

12. Remove the thrust needle bearing.

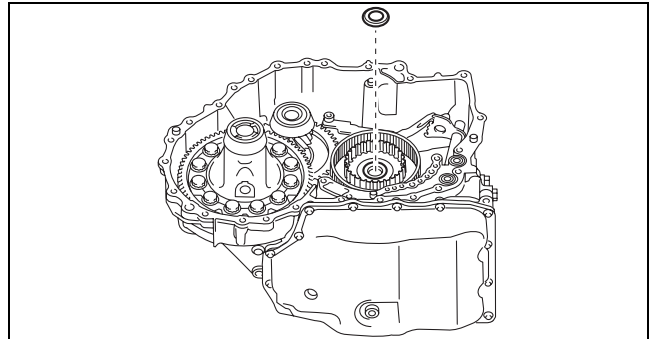

azzjjw00000355

13. Remove the high clutch hub.

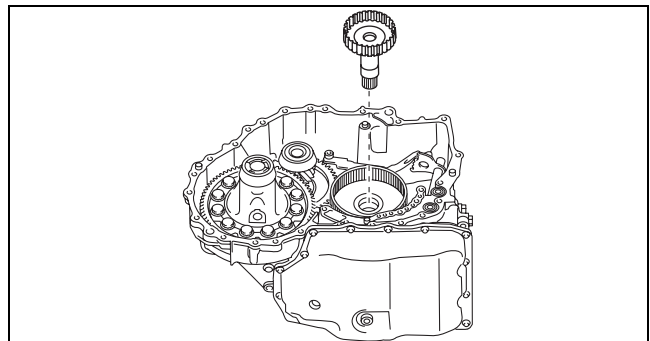

azzjjw00000356

14. Remove the thrust needle bearing.

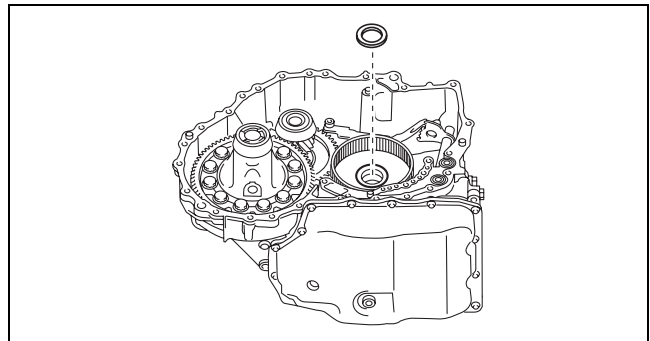

azzjjw00000357

AUTOMATIC TRANSAXLE

15. Remove the low clutch hub.

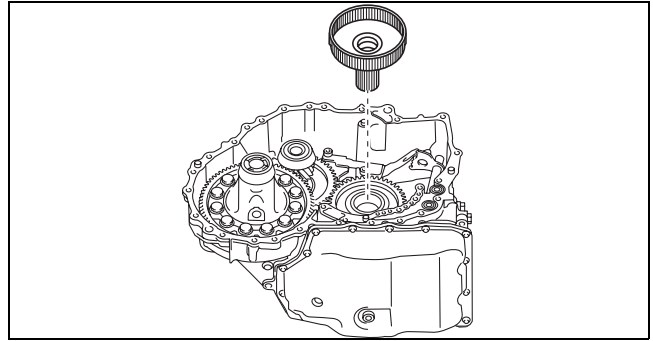

azzjw00000358

16. Remove the thrust needle bearing.

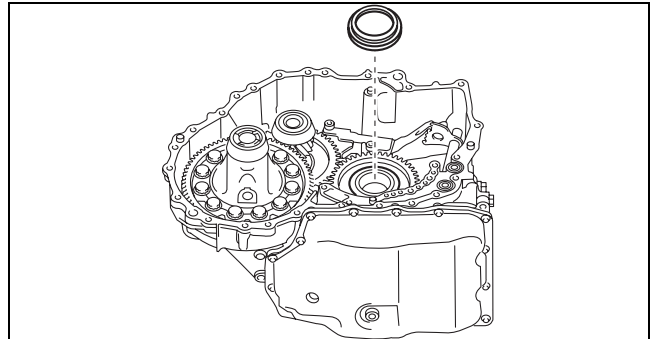

azzjw00000359

17. Remove the ring gear and differential.

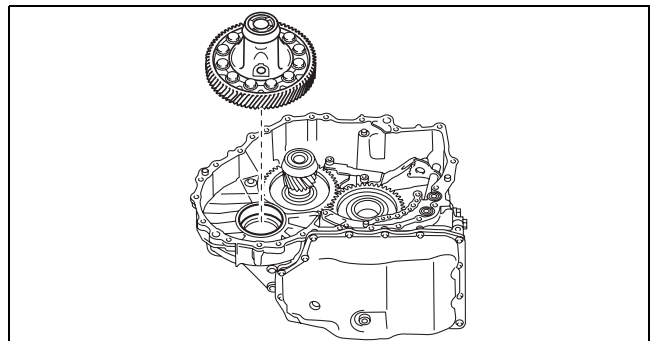

azzjw00000360

18. Remove the oil pipe.

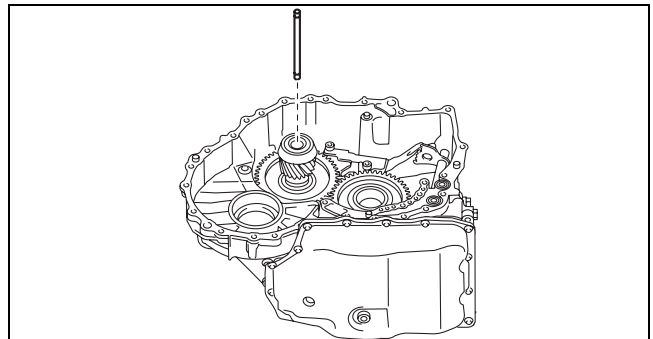

azzjw00000361

AUTOMATIC TRANSAXLE

19. Remove the secondary gear and output gear.

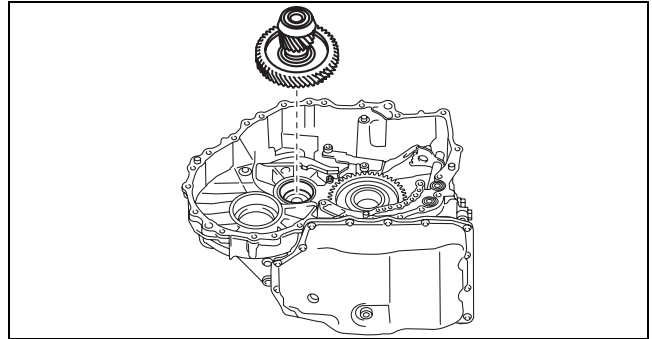

azzjw00000362

05-17

20. Remove the roll pin using the following procedure:

(1) Verify that the parking shift lever component is in the P position.

A : Parking shift lever component

B : Manual plate component

C : Detent bracket component

Caution

- If the parking shift lever component is at a position other than P, shift the parking shift lever component to the P position.

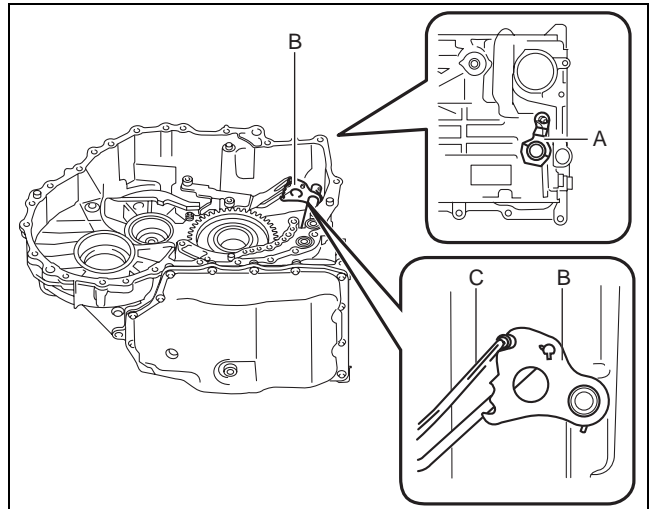

azzjw00001376

(2) Remove the roll pin shown in the figure using a pin punch.

Note

- Use a pin punch with an end outer diameter of 3 mm {0.119 in} or more, and within 4 mm {0.157 in}.

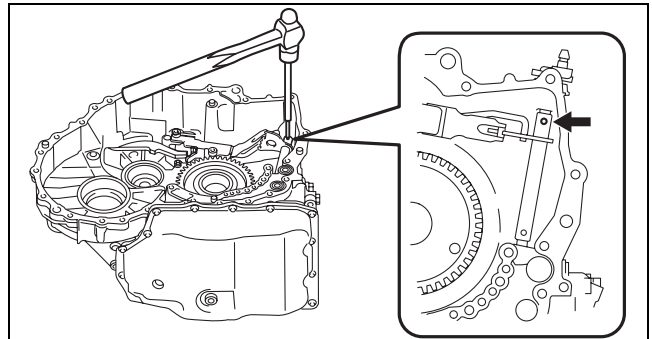

azzjw00001370

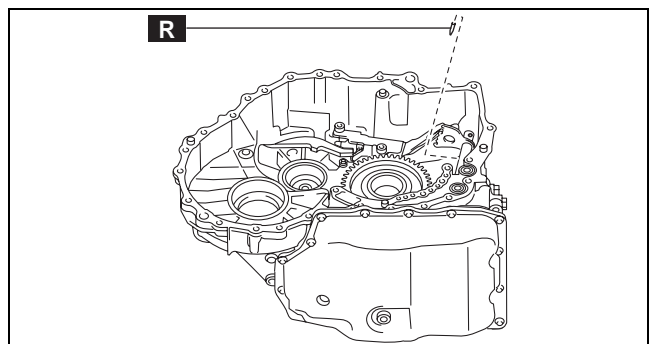

azzjw00001371

AUTOMATIC TRANSAXLE

21. Remove the parking shift lever component.

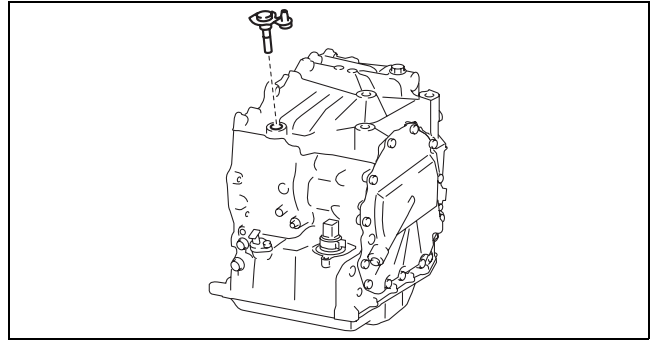

azzjw00000367

22. Remove the oil seal.

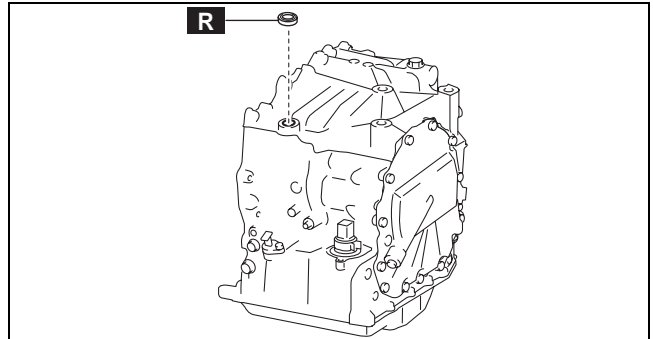

azzjw00000368

Caution

- If the washer comes off together when the oil seal is removed, clean the washer and assemble it.

A: Washer

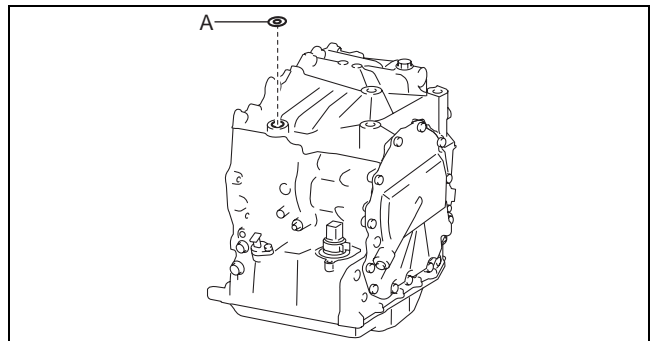

azzjw00001372

AUTOMATIC TRANSAXLE

23. Assemble a new oil seal using the following procedure:

Caution

- If an oil seal is reused it could cause ATF leakage, therefore use a new oil seal.

- (1) Apply ATF (ATF FZ) to the engagement area of the new oil seal and transaxle case.
- (2) Apply ATF (ATF FZ) to the lip of the new oil seal.
- (3) Assemble the new oil seal to the position shown in the figure using the SSTs.

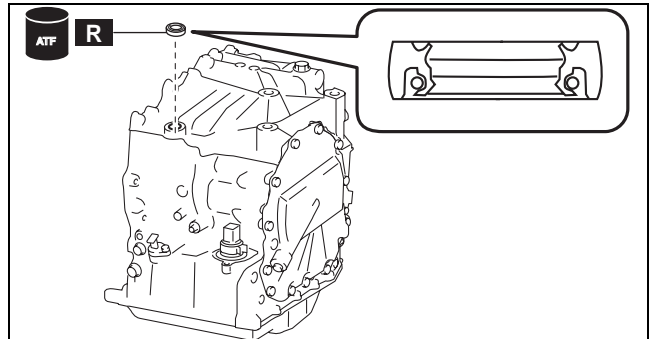

05-17

A : -0.3—0.3 mm {-0.01—0.01 in}

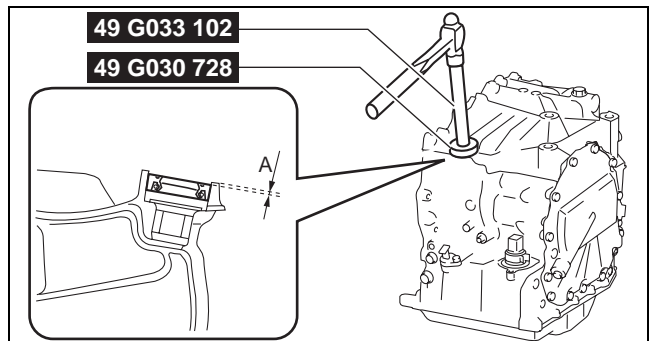

24. Assemble the parking shift lever component.

Note

- Pass the end of the parking shift lever component through the assembly hole (radial needle bearing) of the transaxle case, and assemble it to the manual plate component.

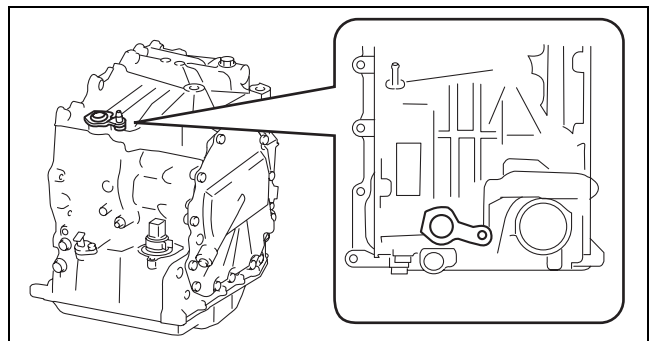
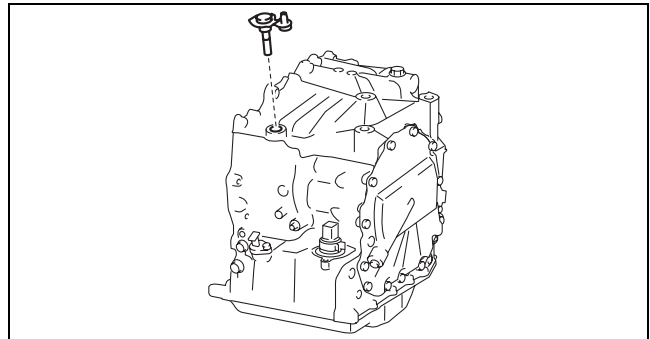

AUTOMATIC TRANSAXLE

25. Assemble a new roll pin using the following procedure:

- (1) Set the manual plate component and parking shift lever component and align with the roll pin hole.

- A : Roll pin hole
B : Manual plate component
C : Parking shift lever component
D : Detent bracket component

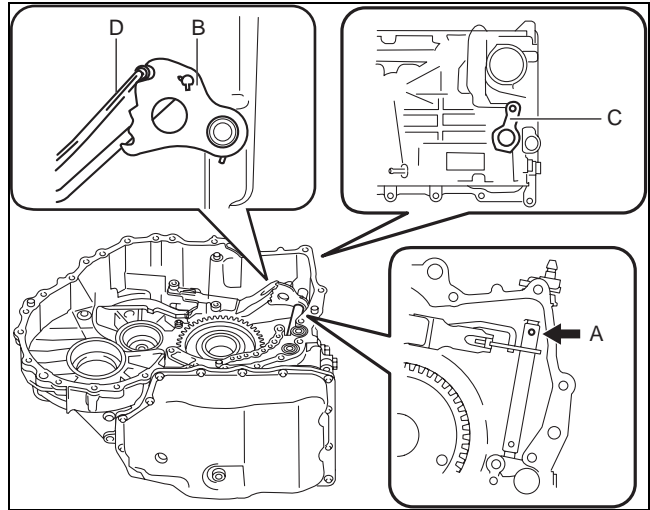

azzjw00001373

- (2) Assemble the new roll pin to the position shown in the figure using a pin punch.

Note

- Use a pin punch with an end outer diameter of 5 mm {0.197 in} or more.

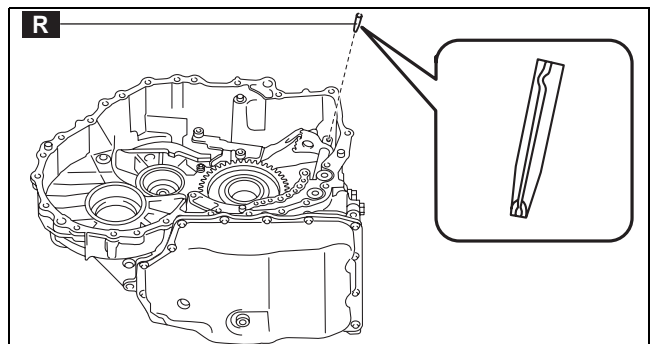

azzjw00001374

A : 0—1 mm {0—0.03 in}

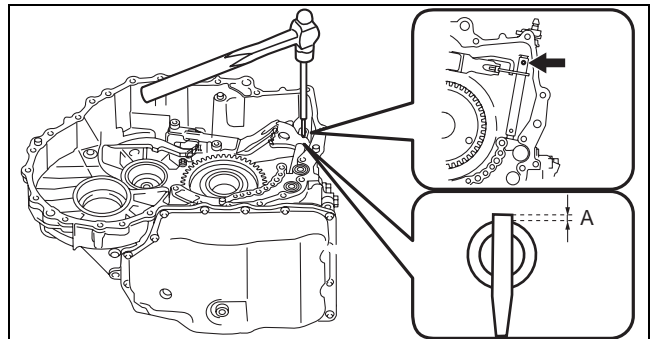

azzjw00001375

AUTOMATIC TRANSAXLE

26. Assemble the secondary gear and output gear.

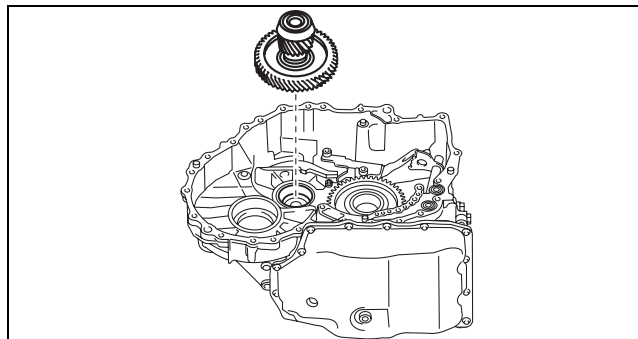

azzjw00000362

05-17

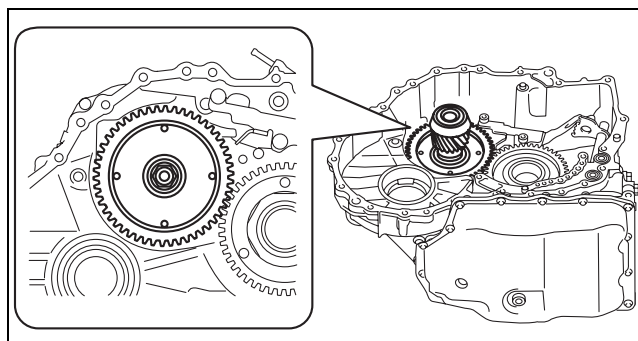

azzjw00000383

27. Assemble the oil pipe.

Caution

- Do not assemble the oil pipe using a tool such as a hammer to prevent damaging the part. For the oil pipe assembly, it is better to only use your hands to put the oil pipe into the output gear.

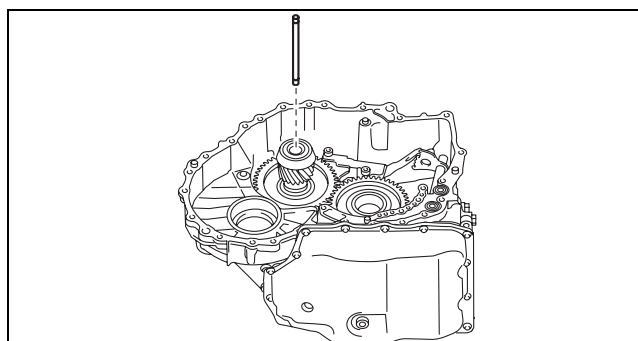

azzjw00000361

28. Assemble the ring gear and differential.

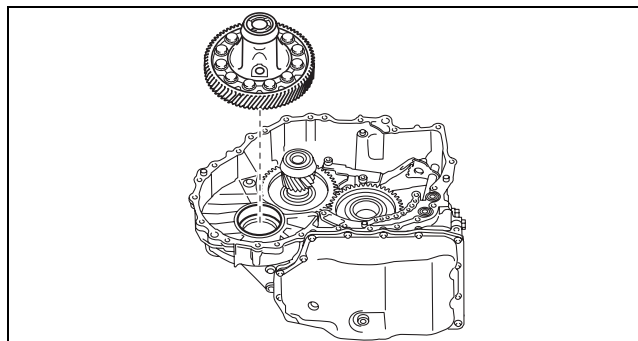

azzjw00000360

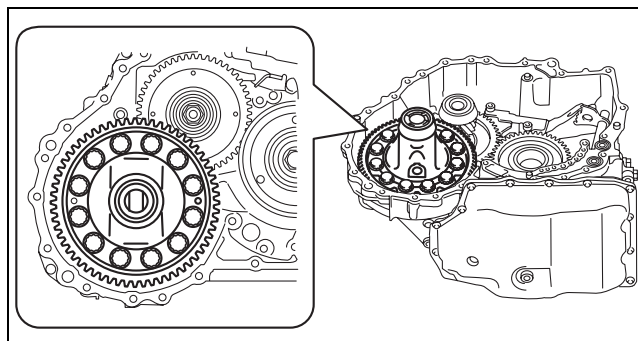

azzjw00000384

AUTOMATIC TRANSAXLE

29. Assemble the thrust needle bearing.

Note

- Thrust needle bearing size: Outer diameter approx. 80.3 mm {3.16 in}

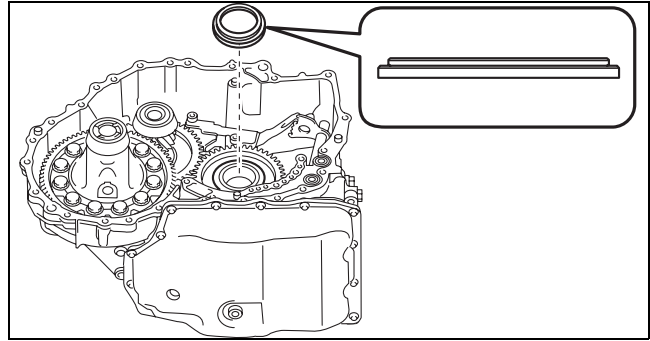

azzjw00000385

30. Assemble a new D-ring and new seal rings to the turbine shaft using the following procedure:

Caution

- If a D-ring is reused it could cause ATF leakage, therefore use a new D-ring.
- If a seal ring is reused it could cause ATF leakage, therefore use a new seal ring.

- (1) Apply ATF (ATF FZ) to the new D-ring and new seal rings.
- (2) Assemble the new D-ring and new seal rings to the turbine shaft using the procedure shown in the figure:

1	Seal ring (outer diameter approx. 24.4 mm {0.961 in}, thickness approx. 1.5 mm {0.059 in})
2	D-ring (outer diameter approx. 16.4 mm {0.646 in}, thickness approx. 2.4 mm {0.094 in})

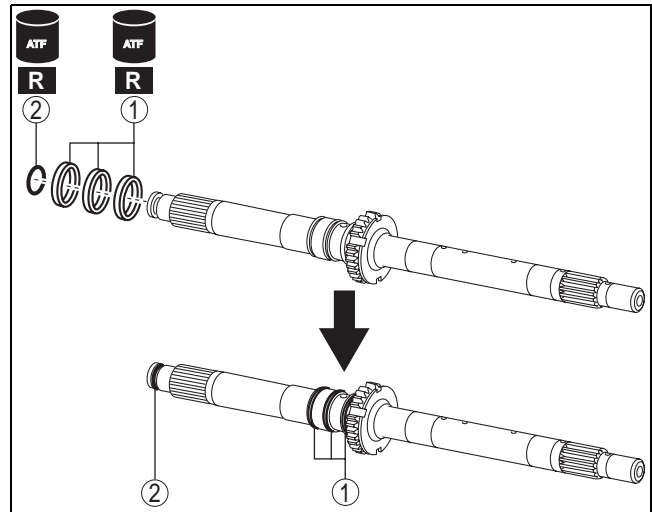

azzjw00000386

31. Assemble together the clutch component, turbine shaft, high clutch hub, low clutch hub, and thrust needle bearing using the following procedure:

- (1) Assemble the parts using the procedure shown in the figure:

1	Clutch component
2	Turbine shaft
3	Thrust needle bearing (outer diameter approx. 37.3 mm {1.47 in})
4	High clutch hub
5	Thrust needle bearing (outer diameter approx. 51.3 mm {2.02 in})
6	Low clutch hub

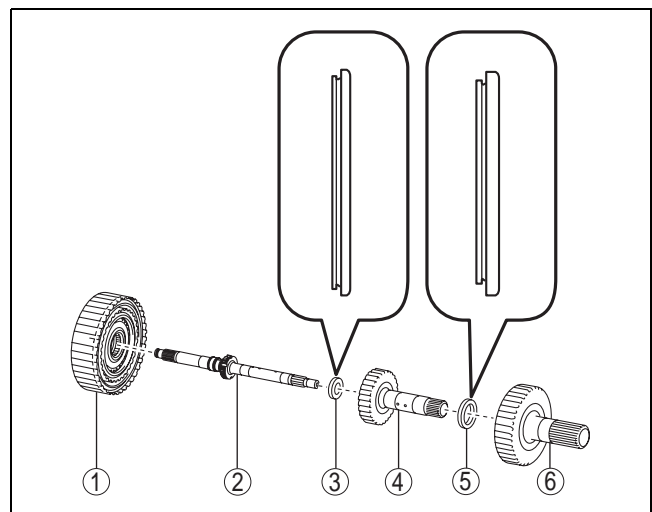

azzjw00001415

Note

- For the high clutch hub and low clutch hub assembly, assembly is easier if the work is performed using the following procedure:

— High clutch hub

1. Place the assembled parts on the workbench with the clutch component situated sideways.

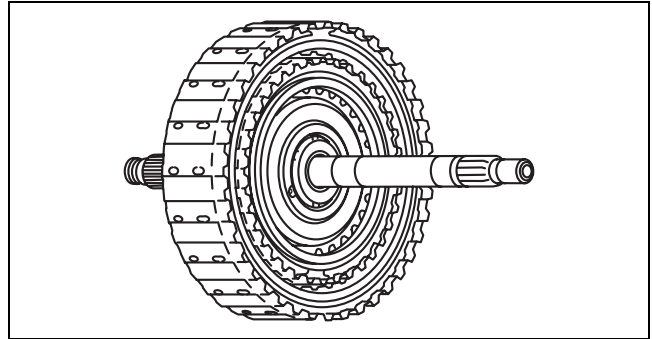

azzjjw00000389

2. While rotating the high clutch hub, engage the splines of each of the high clutch drive plates one by one, and assemble.

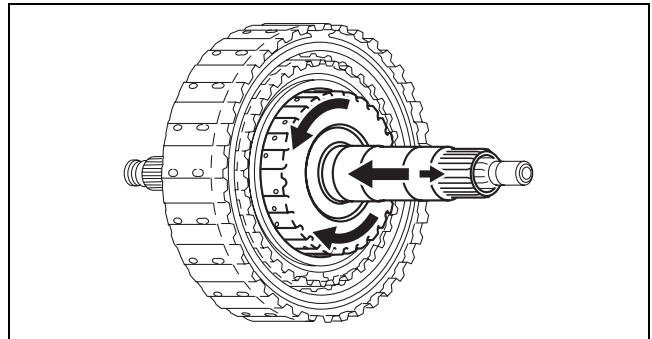

azzjjw00000390

— Low clutch hub

1. Place the assembled parts on the workbench with the clutch component situated sideways.

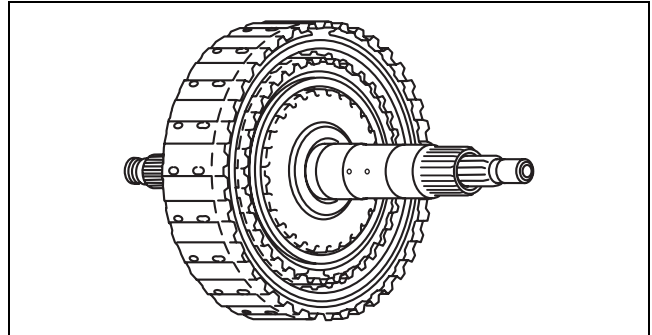

azzjjw00000391

2. While rotating the low clutch hub, engage the splines of each of the low clutch drive plates one by one, and assemble.

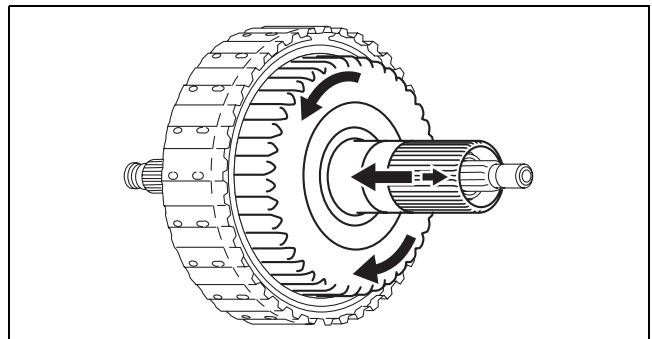

azzjjw00000392

AUTOMATIC TRANSAXLE

- (2) To verify that the parts are securely assembled together, measure the distance shown in the figure.

Note

- Recommended measuring instrument:
Vernier caliper

Specification

63.9—66.0 mm {2.52—2.59 in}

- If not within the specification, disassemble the assembled parts and reassemble.

32. Assemble the parts which were assembled together in Step 31 using the following procedure:

- (1) Assemble the parts assembled together in Step 31.

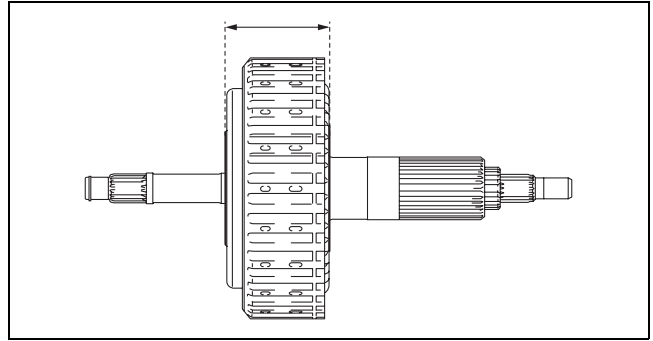

azzjiw00000388

- (2) To verify that the parts are securely assembled, measure the distance shown in the figure.

- A : Transaxle case end (alignment surface with converter housing)
B : Clutch component end

Note

- Recommended measuring instrument:
Depth gauge, straight edge ruler

Specification

11.6—14.8 mm {0.457—0.582 in}

- If not within the specification, remove the parts and perform re-assembly from Step 31.

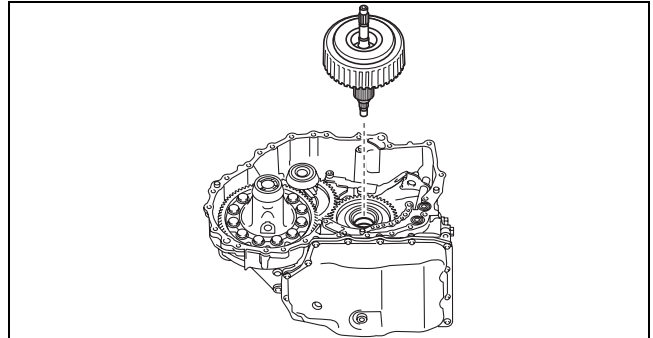

azzjiw00000393

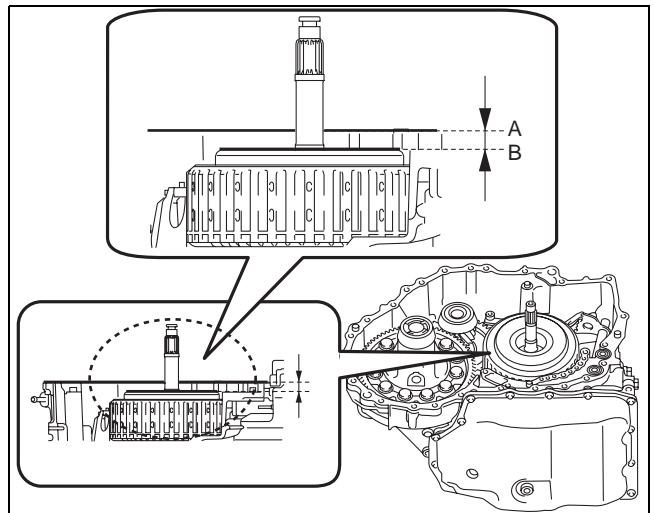

azzjiw00001456

Note

- Measurement method

- 1) Set two straight edge rulers along the alignment surface of the transaxle case with the converter housing as shown in the figure.

A : Straight edge ruler

- 2) Measure the positions (2 locations) shown in the figure using a depth gauge and calculate the average value.
- 3) Subtract the thickness of the straight edge ruler from the average value.

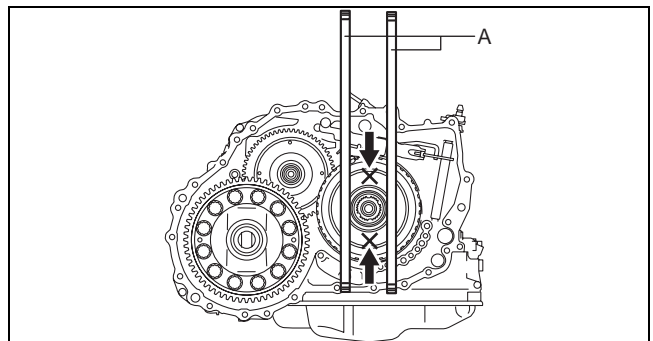

azzjiw00000395

AUTOMATIC TRANSAXLE

33. Assemble the thrust needle bearing.

Note

- Thrust needle bearing size: Outer diameter approx. 72.7 mm {2.86 in}

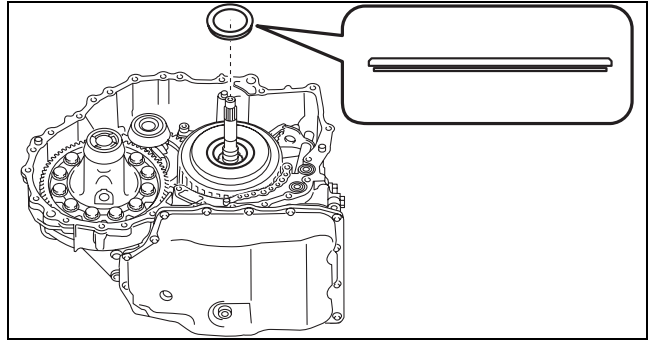

azzjjw00000396

05-17

34. Assemble the oil pump using the following procedure:

1	Oil pump
2	7 bolts (M8×1.25 bolt, length to approx. 31 mm {1.2 in})

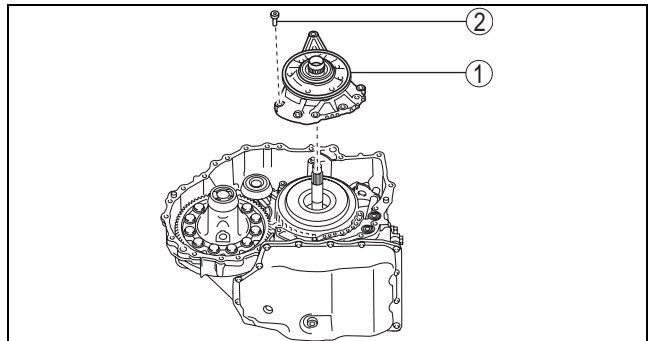

azzjjw00000397

(1) Assemble the oil pump.

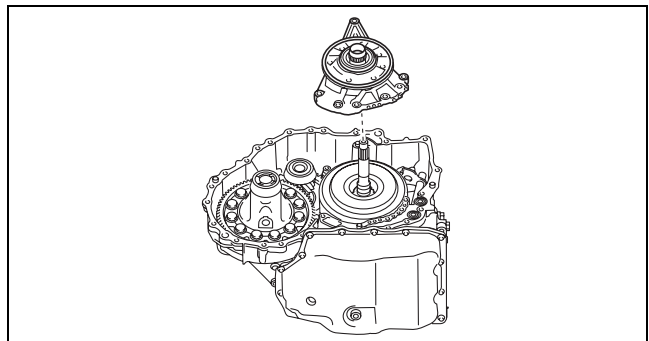

azzjjw00000350

(2) Assemble and tighten the bolts shown in the figure.

Note

- Bolt size: M8×1.25 bolt, length to approx. 31 mm {1.2 in}

Tightening torque

19—25 N·m {2.0—2.5 kgf·m, 15—18 ft·lbf}

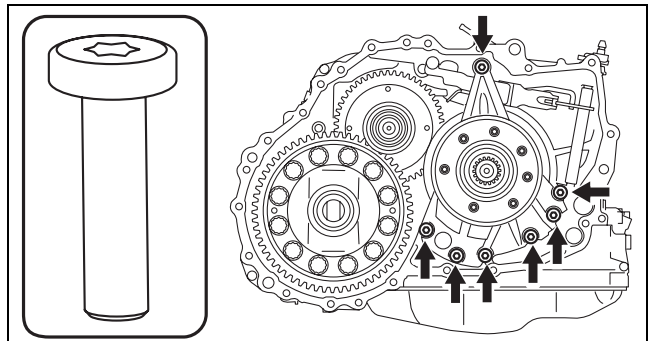

azzjjw00000398

AUTOMATIC TRANSAXLE

35. Assemble the baffle plate.

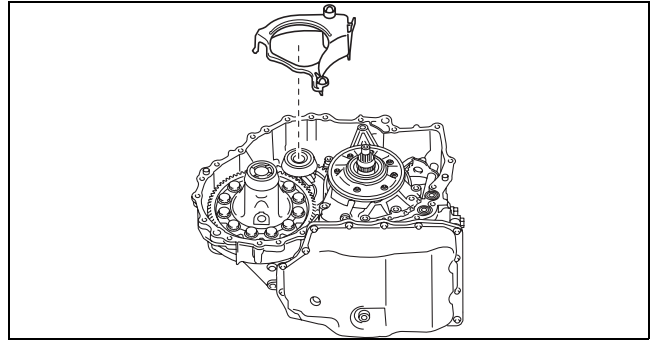

azzijw00000347

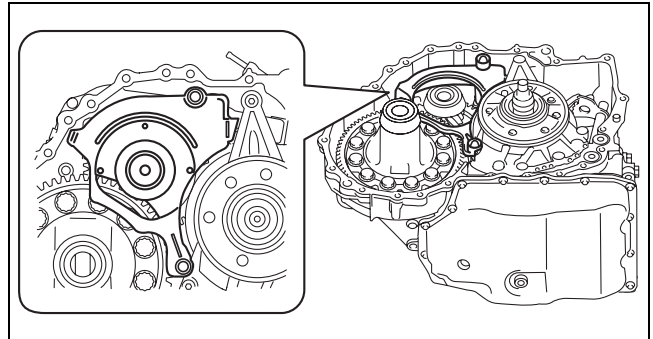

azzijw00000399

36. Assemble the converter housing using the following procedure:

1	O-ring (outer diameter approx. 15.6 mm {0.614 in}, thickness approx. 2.4 mm {0.094 in})
2	O-ring (outer diameter approx. 73.3 mm {2.89 in}, thickness approx. 3.0 mm {0.12 in})
3	Converter housing
4	24 bolts * (M8×1.25 bolt, length to approx. 28 mm {1.1 in})

* : Of the 24 bolts, 6 are applied with sealant

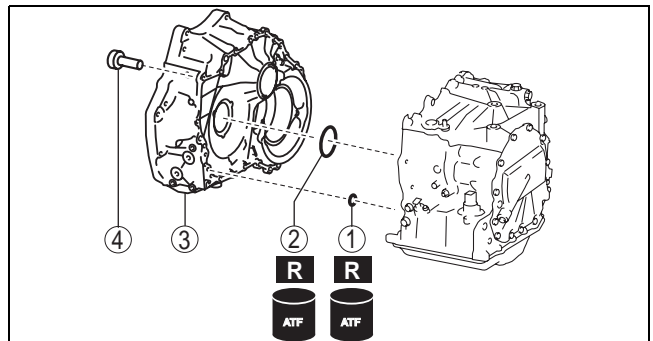

azzijw00000328

AUTOMATIC TRANSAXLE

(1) Assemble new O-rings using the following procedure:

Caution

- If an O-ring is reused it could cause ATF leakage, therefore use a new O-ring.

- 1) Apply ATF (ATF FZ) to the new O-rings.
- 2) Assemble the new O-rings.

1	O-ring (outer diameter approx. 15.6 mm {0.614 in}, thickness approx. 2.4 mm {0.094 in})
2	O-ring (outer diameter approx. 73.3 mm {2.89 in}, thickness approx. 3.0 mm {0.12 in})

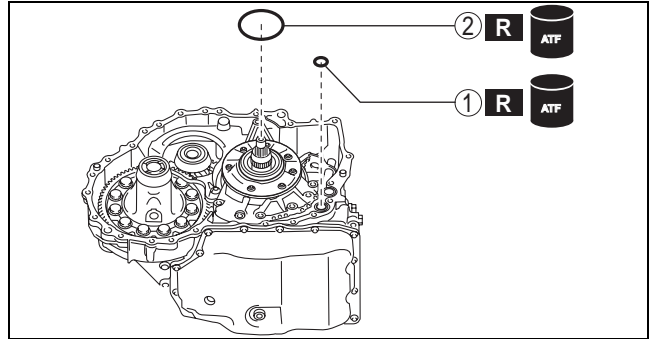

azzjjw00000329

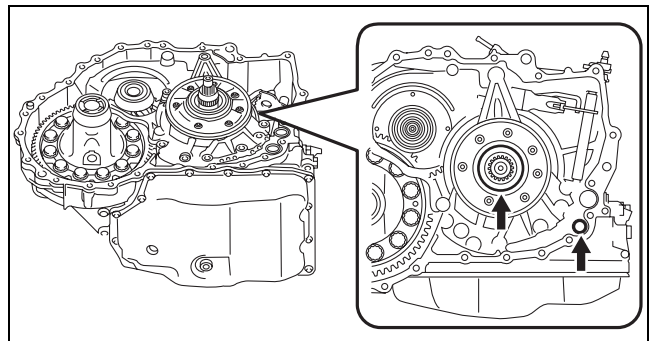

azzjjw00000330

(2) Remove any remaining old sealant on the contact surfaces of the transaxle case and converter housing, and degrease the contact surfaces.

Caution

- When degreasing and if degreaser is used, use a rag saturated with degreaser and be careful not to allow degreaser to penetrate the interior of the transaxle. In addition, after degreasing, visually verify that there is no foreign matter (such as old sealant, cloth fibers) which has penetrated the interior of the transaxle.

(3) Apply sealant (silicone sealant TB1217E) to the transaxle case.

Caution

- If sealant is applied excessively or applied to a part other than the indicated part, the O-ring could deform and the sealant could penetrate the oil passage. Apply an appropriate amount of sealant to the indicated part.

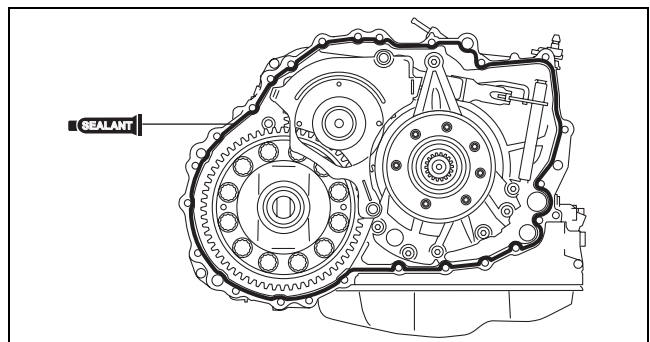

azzjjw00000331

Note

- Sealant application amount (bead thickness): ϕ 1.8—2.5 mm {0.071—0.098 in}

AUTOMATIC TRANSAXLE

- (4) Assemble the converter housing before the applied sealant starts to harden.

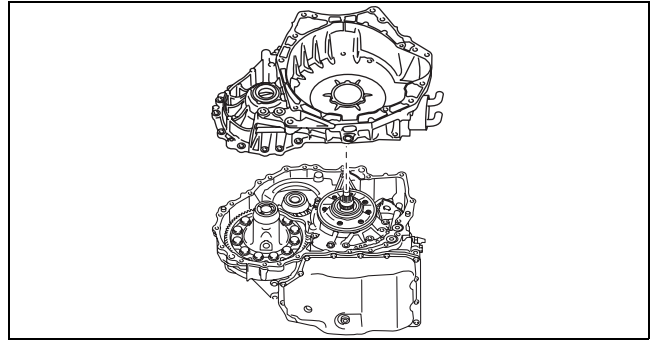

azzjw00000317

- (5) Assemble and temporarily tighten the bolts to the positions shown in the figure.

Note

- Bolt size: M8×1.25 bolt, length to approx. 28 mm {1.1 in}

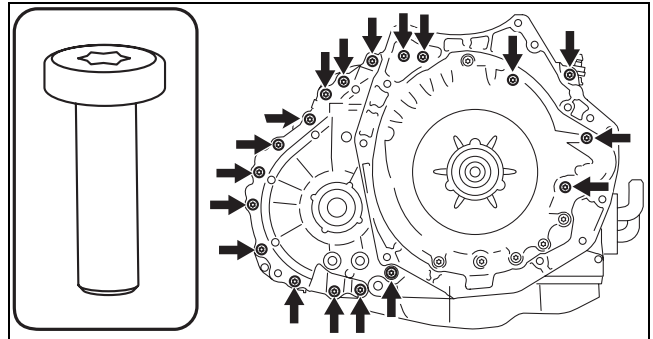

azzjw00000332

- (6) Assemble and temporarily tighten the new bolts to the positions shown in the figure.

Caution

- The bolts for the assembly are applied with sealant. If the bolts are reused it could cause ATF leakage, therefore use new bolts.

Note

- Bolt size: M8×1.25 bolt, length to approx. 28 mm {1.1 in} (with sealant applied)

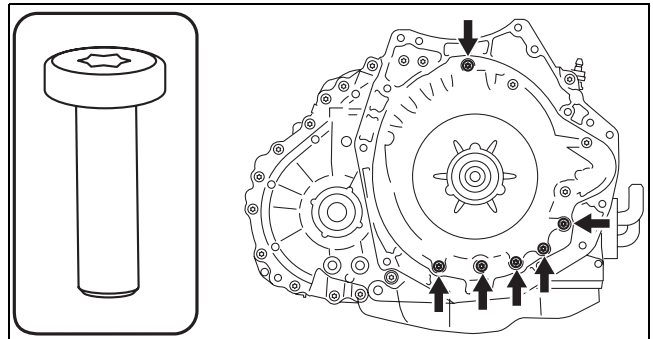

azzjw00000333

- (7) Tighten the bolts shown in the figure.

Tightening torque

19—25 N·m {2.0—2.5 kgf·m, 15—18 ft·lbf}

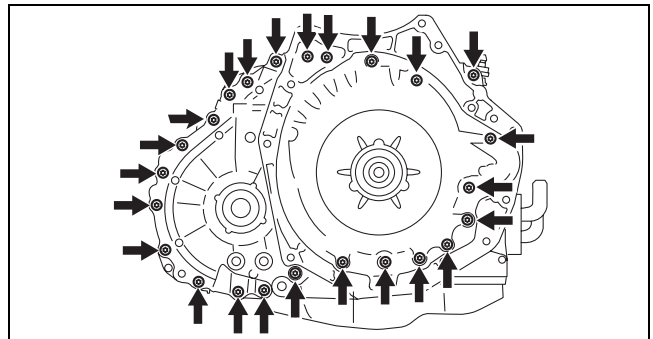

azzjw00000334

AUTOMATIC TRANSAXLE

37. Remove the SSTs from the transaxle using the following procedure:

Caution

- When removing the transaxle from the SST (engine stand) using chain hoists, be careful not to allow the transaxle (oil cooler in particular) to contact the SST (engine stand). If the transaxle contacts the SST, check the areas that made contact and replace damaged parts with new ones.

(1) Assemble the SSTs using part number: 9YA02 1015, or M10×1.5 bolts, length to 35 mm {1.4 in}.

A : Part number: 9YA02 1015, or M10×1.5 bolt, length to 35 mm {1.4 in}

Tightening torque

38—52 N·m {3.9—5.3 kgf·m, 29—38 ft·lbf}

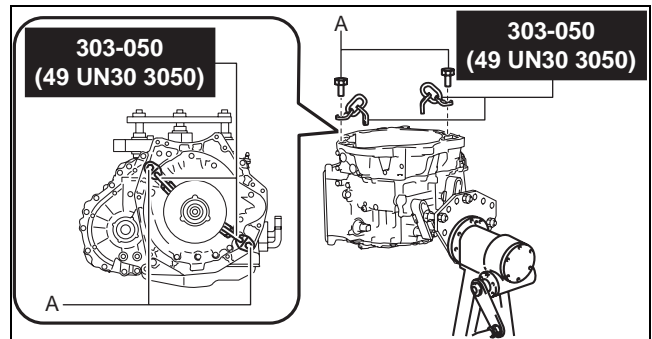

azzjw00000335

(2) Using chain hoists, remove the SST (engine stand) from the transaxle.

A : Part number: 9YA02 A220, or M12×1.75 bolt, length to 40 mm {1.6 in}

Caution

- When removing the transaxle from the SST (engine stand) using chain hoists, be careful not to allow the transaxle (oil cooler in particular) to contact the SST (engine stand). If the transaxle contacts the SST, check the areas that made contact and replace damaged parts with new ones.

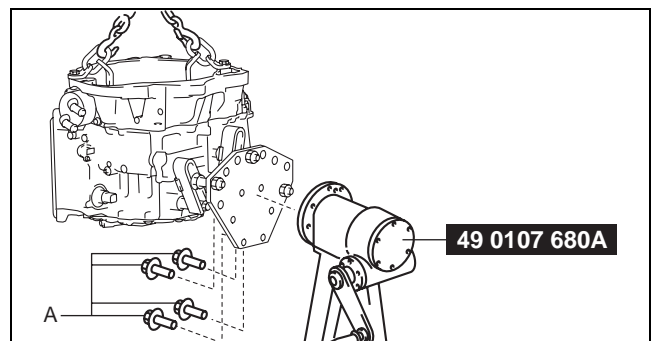

azzjw00000311

(3) Remove the SSTs.

A : Part number: 9YA02 1015, or M10×1.5 bolt, length to 35 mm {1.4 in}

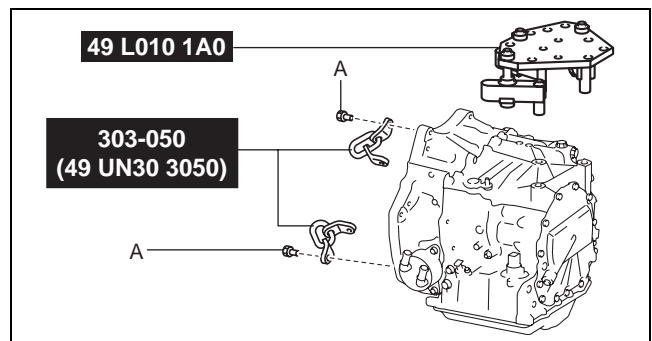

azzjw00000336

05-17

AUTOMATIC TRANSAXLE

(4) Disassemble the SST.

A : Part number: 9YA02 1440, or M14×1.5 bolt,
length to 100 mm {3.94 in}

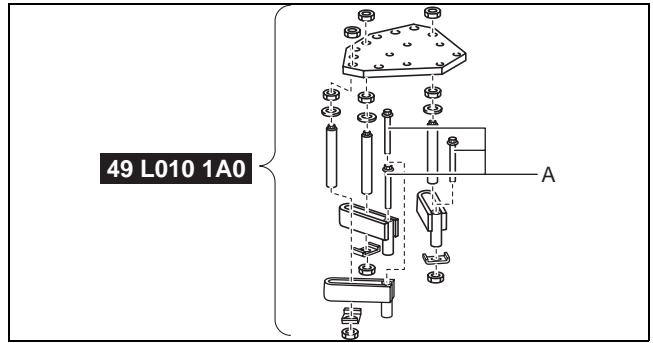

azzjiw00000337

38. Assemble the torque converter using the following procedure:

(1) Apply ATF (ATF FZ) to the end of the starter shaft of the oil pump shown in the figure.

Caution

- Accurately perform to protect the torque converter internal parts.

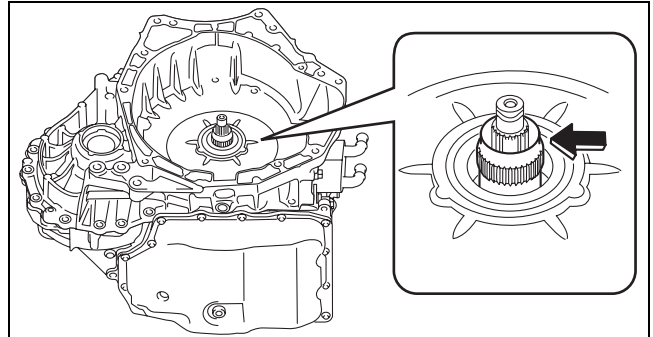

azzzcw00000083

(2) Assemble the torque converter so that the two surfaces of the notch on the end of the torque converter engage the inner rotor of the oil pump.

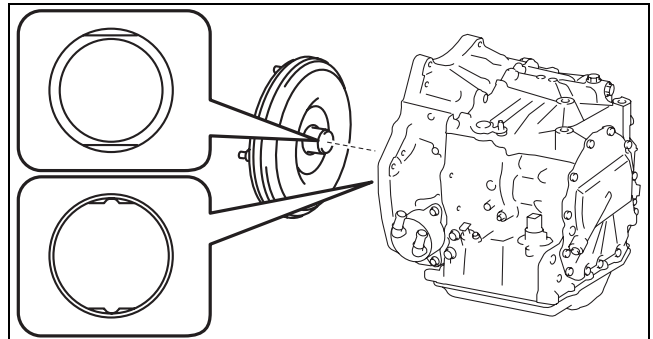

azzjiw00000338

(3) To verify that the torque converter is securely assembled, measure the distance shown in the figure.

A : Converter housing end (alignment surface with engine)

B : Torque converter stud bolt seat

Note

- Recommended measuring instrument:
Depth gauge, straight edge ruler

Specification

14.6 mm {0.575 in} or more

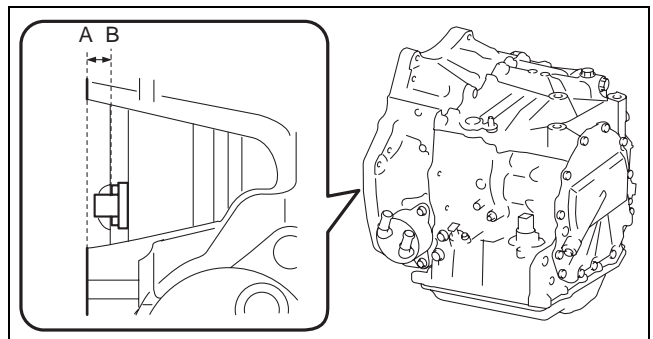

azzjiw00001418

- If not within the specification, remove the torque converter and reassemble.

Note

- Measurement method

- 1) Set two straight edge rulers along the alignment surface of the converter housing with the engine as shown in the figure.

A : Straight edge ruler

- 2) Measure the positions (2 locations) shown in the figure using a depth gauge and calculate the average value.
- 3) Subtract the thickness of the straight edge ruler from the average value.

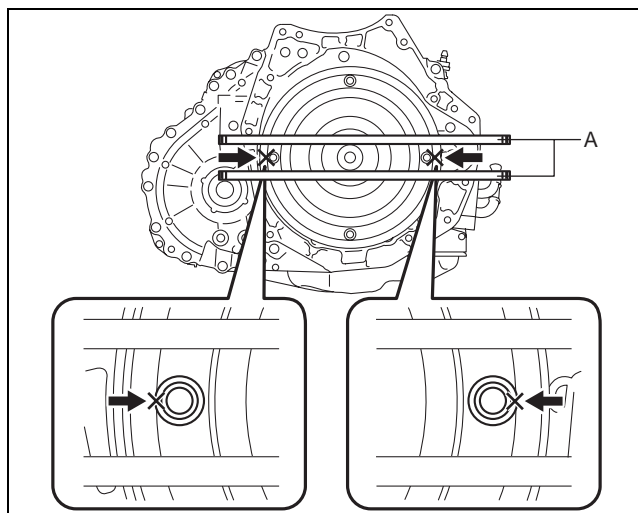

azzjw00000340

39. Assemble and tighten the stud bolts.

Tightening torque

15—25 N·m {1.6—2.5 kgf·m, 12—18 ft·lbf}

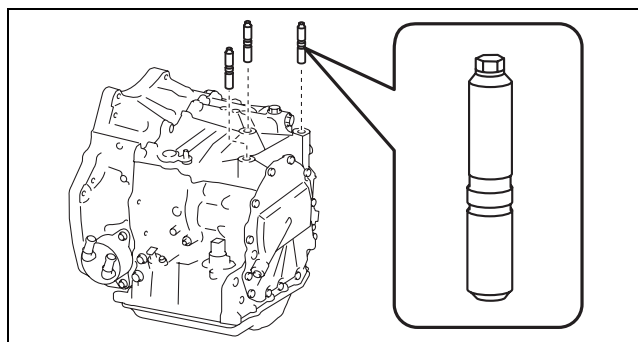

azzjw00000341

AUTOMATIC TRANSAXLE

AUTOMATIC TRANSAXLE DISASSEMBLY

id051700660600

Structural View Automatic transaxle 1

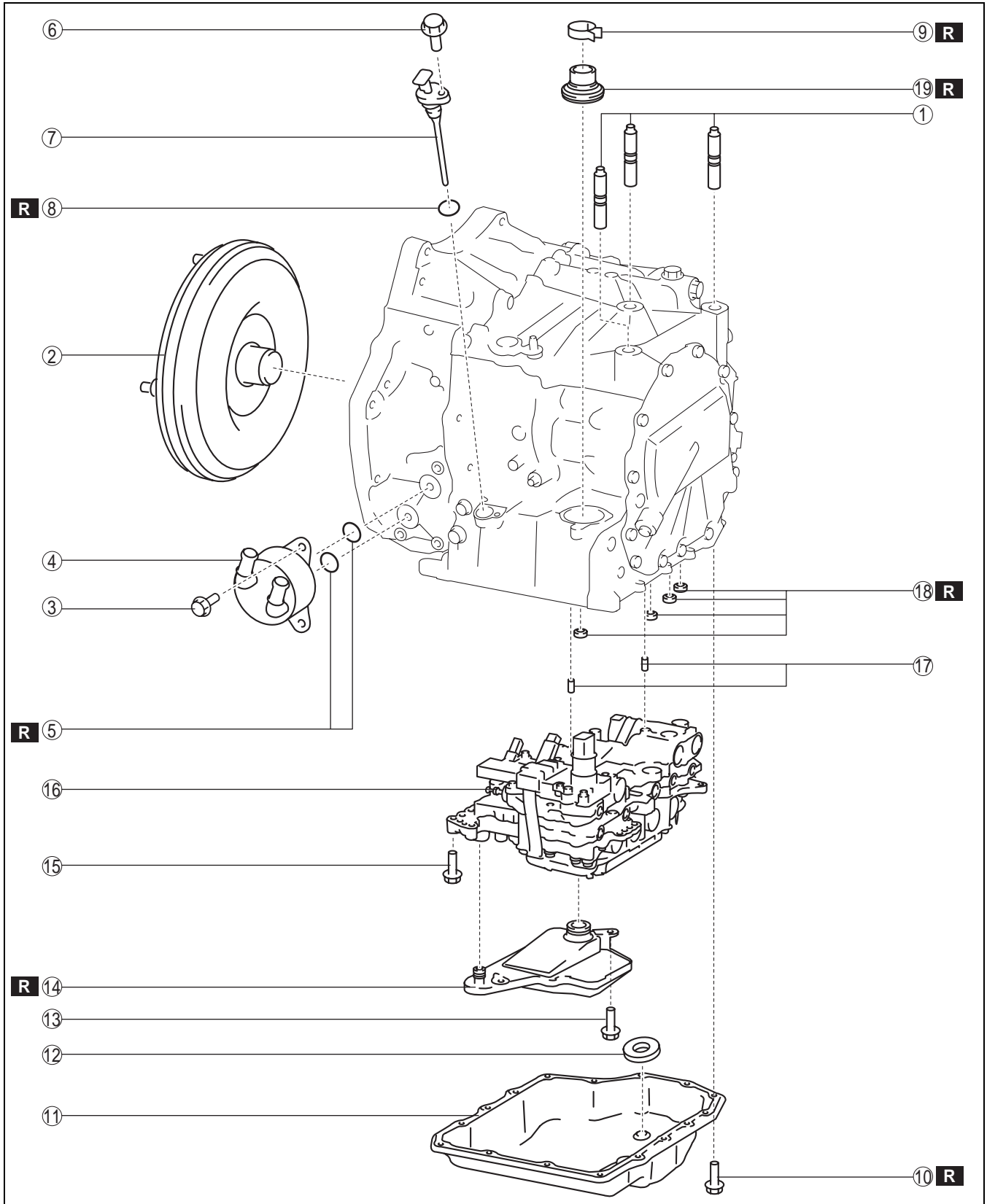

bfw1ua00000001

AUTOMATIC TRANSAXLE

1	Stud bolt
2	Torque converter
3	3 bolts
4	Oil cooler
5	O-ring
6	Bolt
7	Dipstick
8	O-ring
9	Hose clamp
10	16 bolts

11	Oil pan
12	Magnet
13	2 bolts
14	Oil strainer
15	11 bolts
16	Control valve body
17	Dowel pin
18	Gasket
19	Oil seal

05-17

Automatic transaxle 2

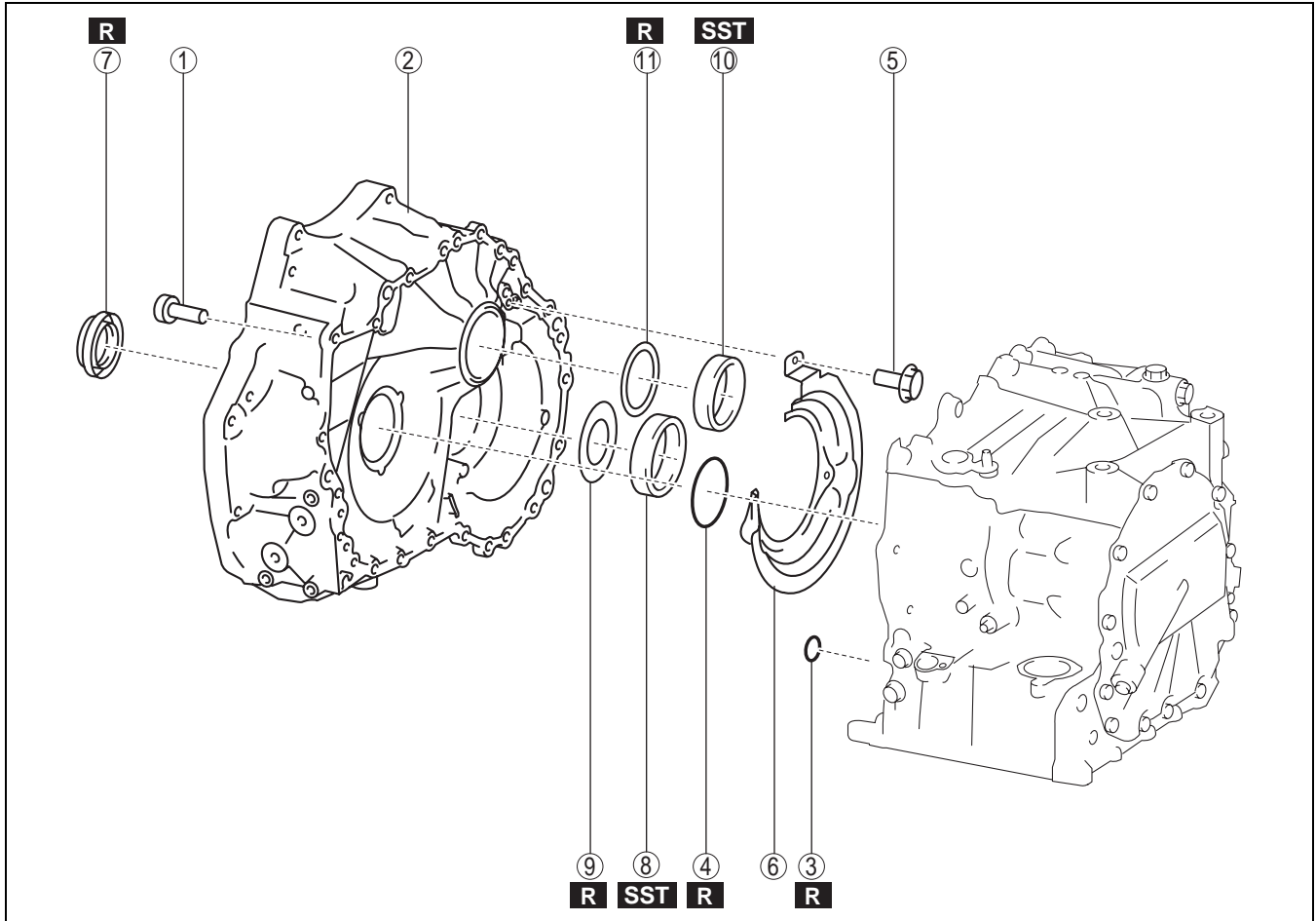

azzjjw00001420

1	24 bolts
2	Converter housing
3	O-ring
4	O-ring
5	3 bolts
6	Baffle plate

7	Oil seal
8	Bearing race
9	Shim
10	Bearing race
11	Shim

AUTOMATIC TRANSAXLE

Automatic transaxle 3

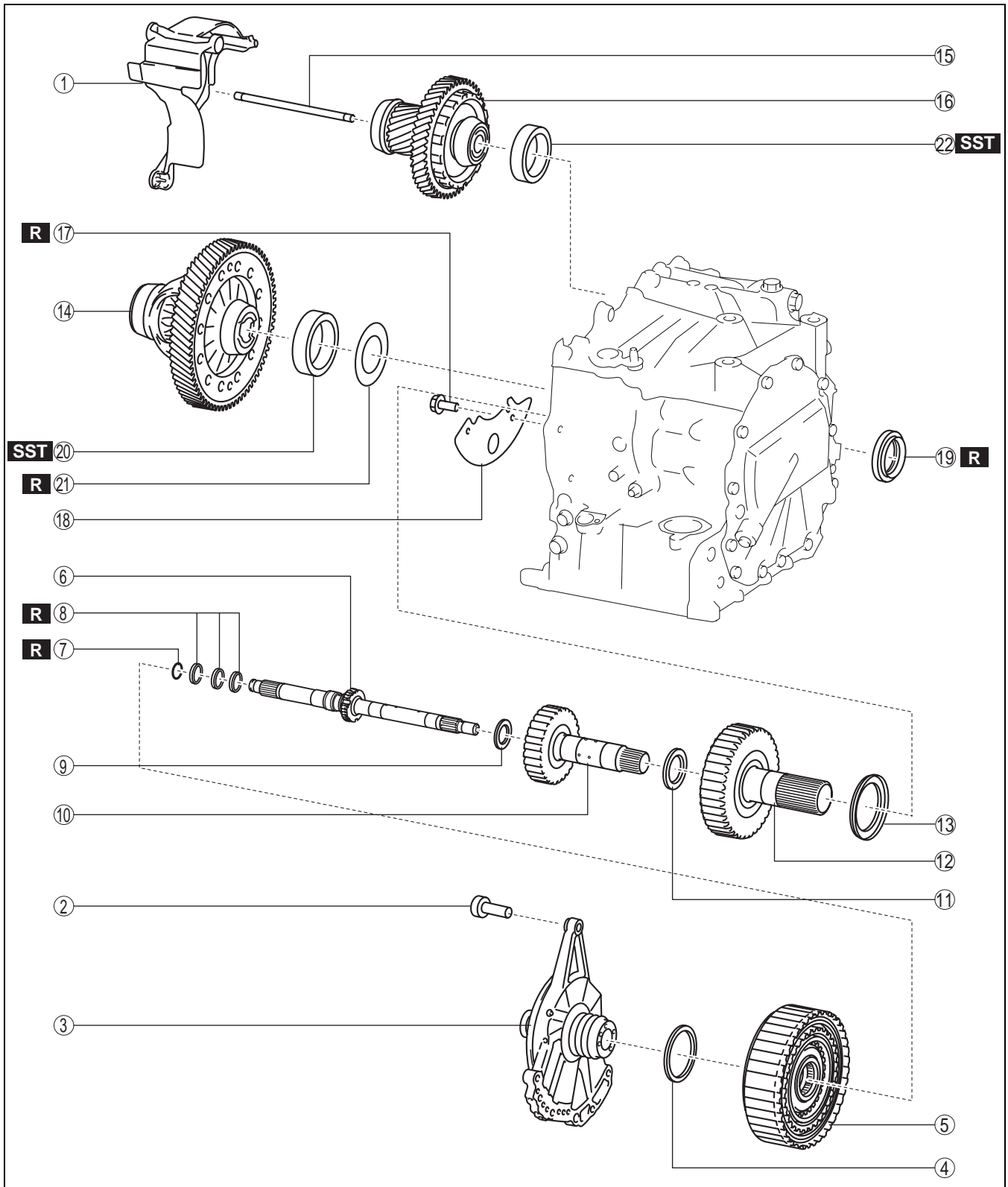

azzjiw00001421

1	Baffle plate
2	7 bolts
3	Oil pump
4	Thrust needle bearing
5	Clutch component
6	Turbine shaft

7	D-ring
8	Seal ring
9	Thrust needle bearing
10	High clutch hub
11	Thrust needle bearing
12	Low clutch hub

AUTOMATIC TRANSAXLE

13	Thrust needle bearing
14	Ring gear and differential
15	Oil pipe
16	Secondary gear and output gear
17	2 bolts

18	Baffle plate
19	Oil seal
20	Bearing race
21	Shim
22	Bearing race

05-17

Automatic transaxle 4

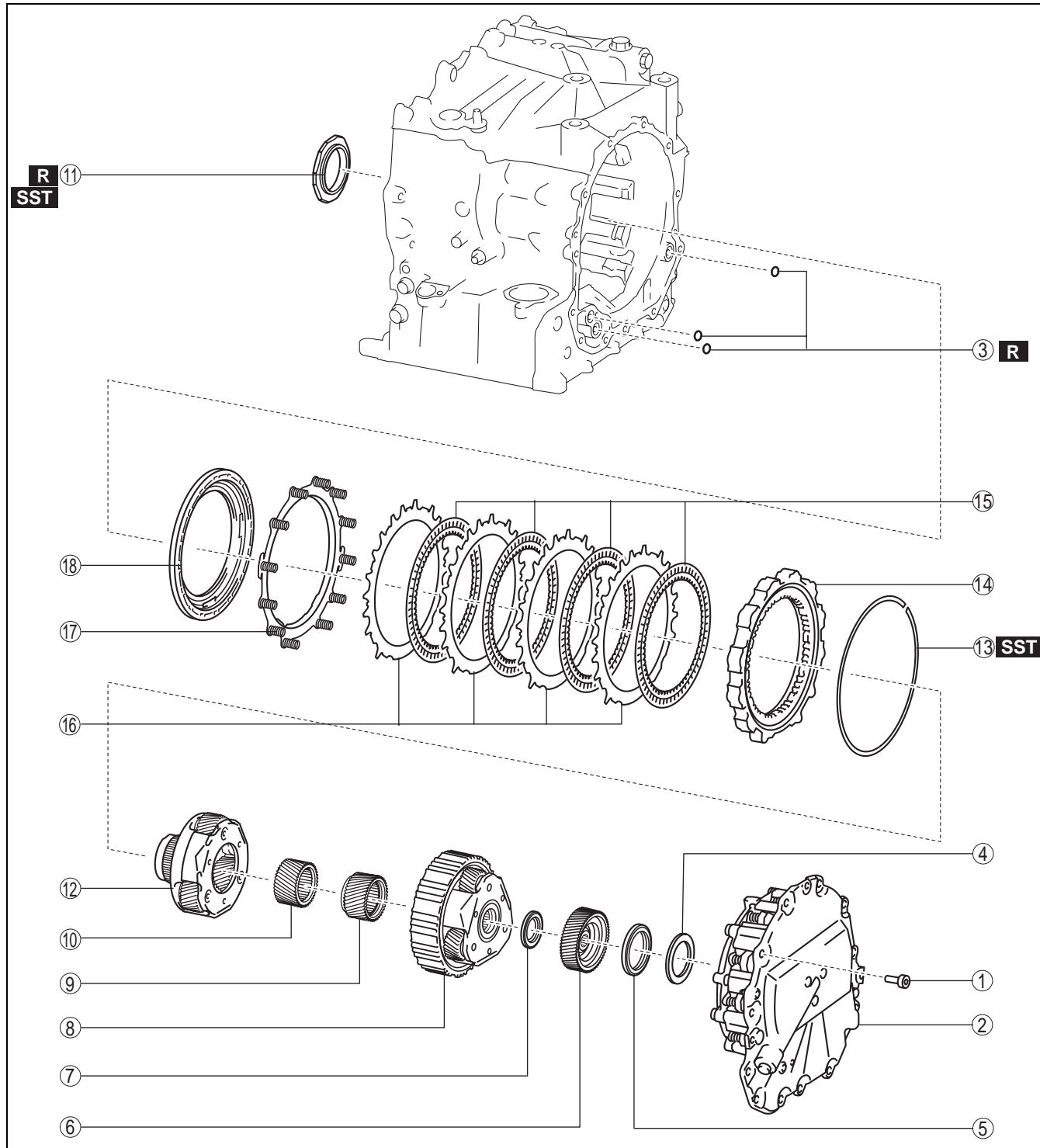

azzjjw00001422

AUTOMATIC TRANSAXLE

1	12 bolts
2	End cover component
3	O-ring
4	Shim
5	Thrust needle bearing
6	Reduction sun gear
7	Thrust needle bearing
8	Rear planetary gear
9	Rear sun gear

10	Front sun gear
11	Locknut
12	Front planetary gear
13	Snap ring
14	One-way clutch
15	Drive plate
16	Driven plate
17	Springs and retainer component
18	Low and reverse brake piston

Automatic transaxle 5

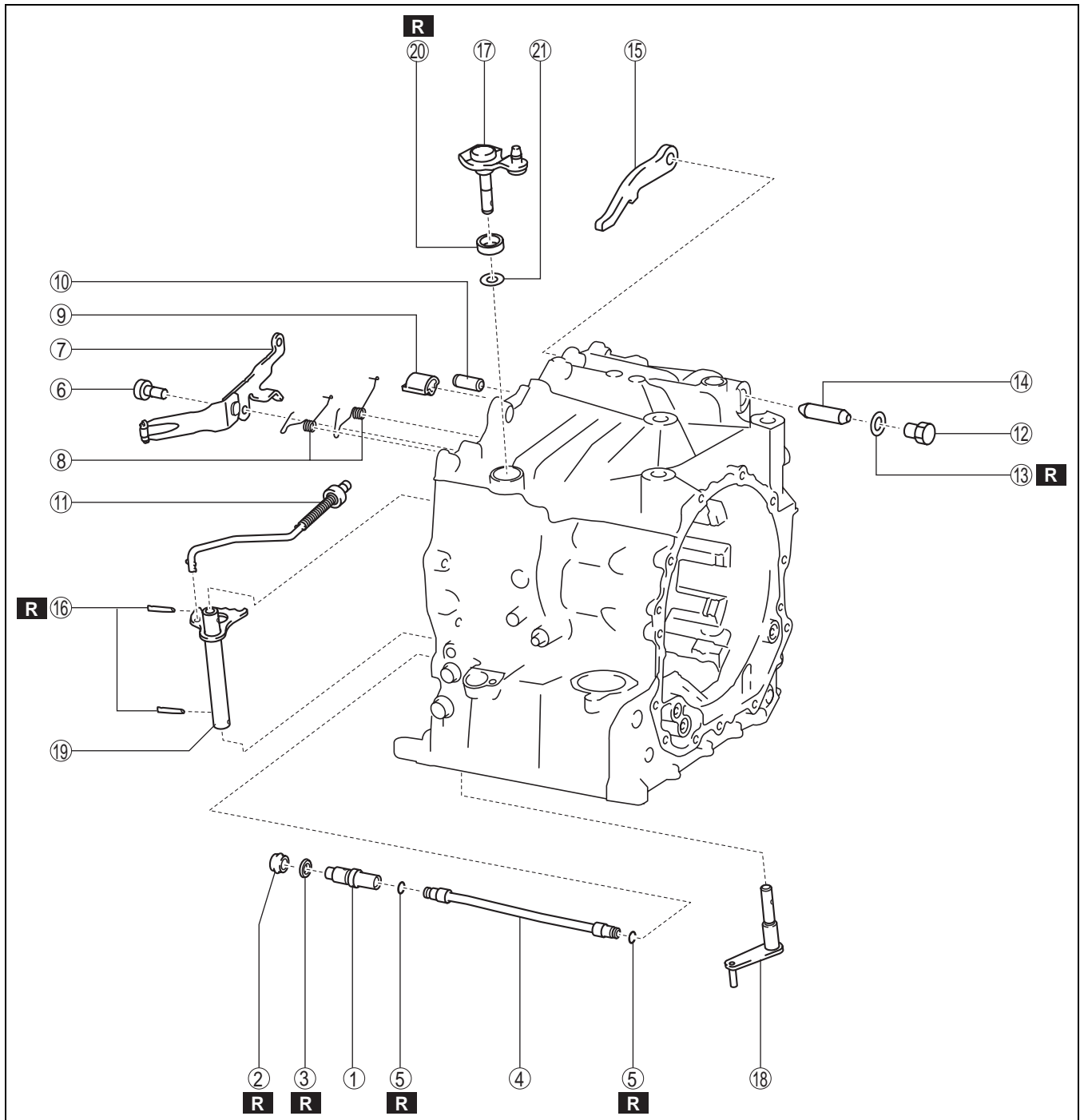

azzjw00001423

AUTOMATIC TRANSAXLE

1	Connector
2	Gasket
3	Gasket
4	Oil pipe
5	O-ring
6	2 bolts
7	Detent bracket component
8	Pawl return spring
9	Support actuator
10	Parking pawl pin
11	Parking rod component

12	Plug
13	Gasket
14	Parking pawl shaft
15	Parking pawl
16	Roll pin
17	Parking shift lever component
18	Parking assist lever component
19	Manual plate component
20	Oil seal
21	Washer

05-17

Automatic transaxle 6

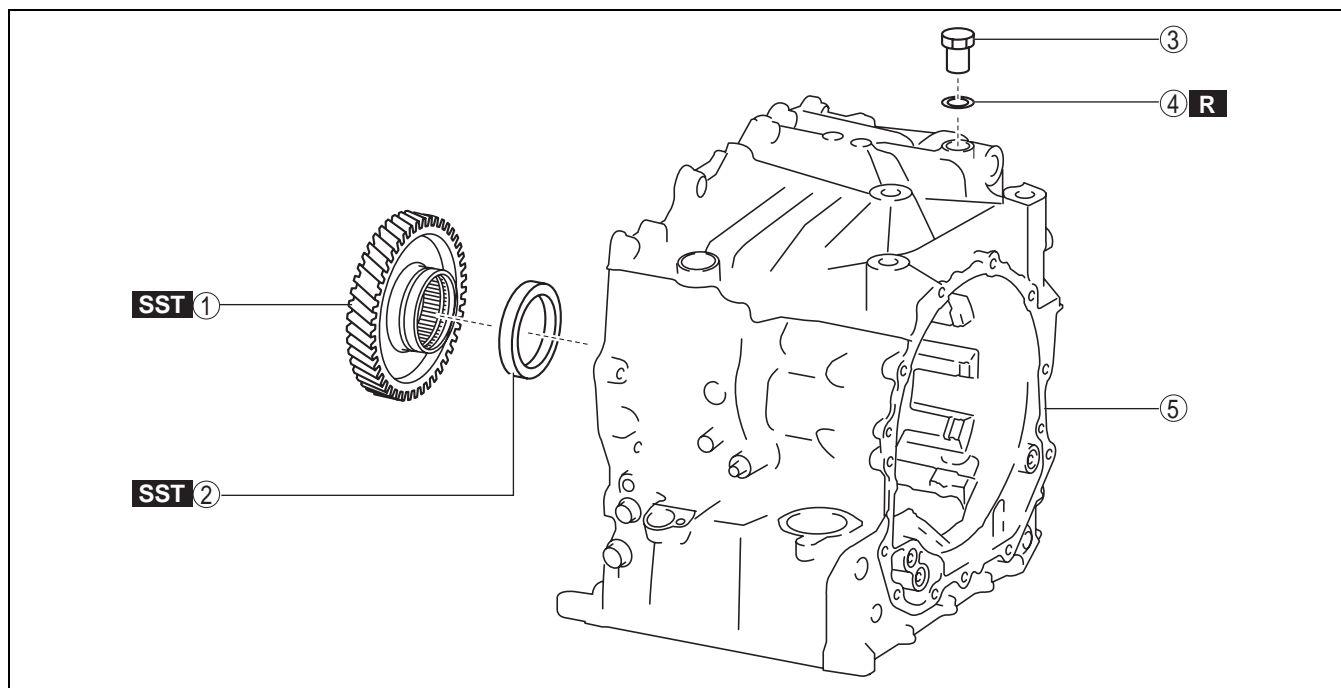

azzjjw00001463

1	Primary gear
2	Angular contact ball bearing
3	Plug

4	Gasket
5	Transaxle case

AUTOMATIC TRANSAXLE

Disassembly Procedure

1. Clean the outside of the transaxle. (See 05-17-26 AUTOMATIC TRANSAXLE CLEANING.)
2. Remove the stud bolts.

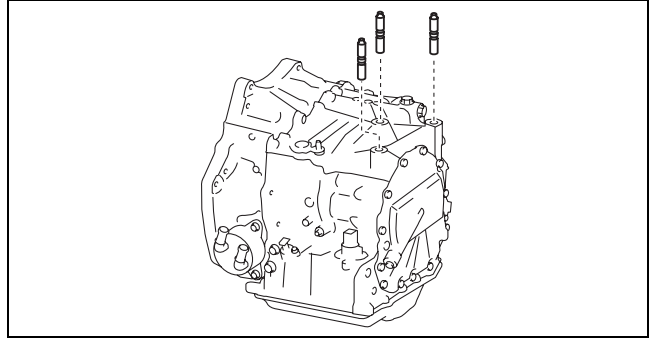

azzjw00000410

3. Remove the torque converter.

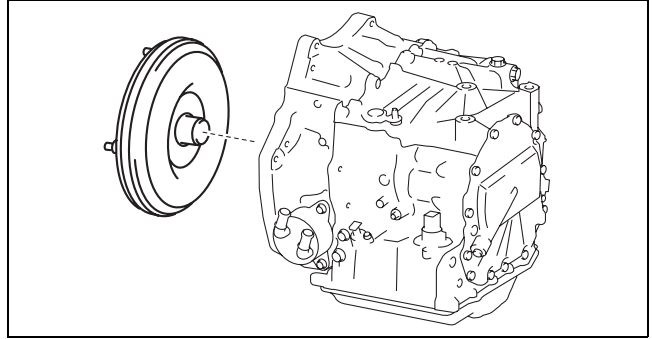

azzjw00000411

4. Remove the oil cooler in the order shown in the figure.

1	Bolt
2	Oil cooler
3	O-ring

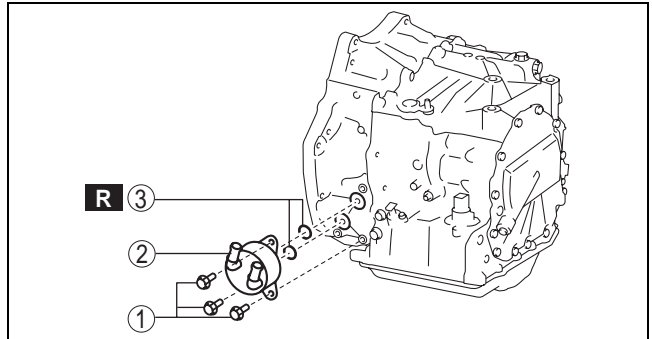

azzjw00000412

5. Remove the dipstick in the order shown in the figure.

1	Bolt
2	Dipstick
3	O-ring

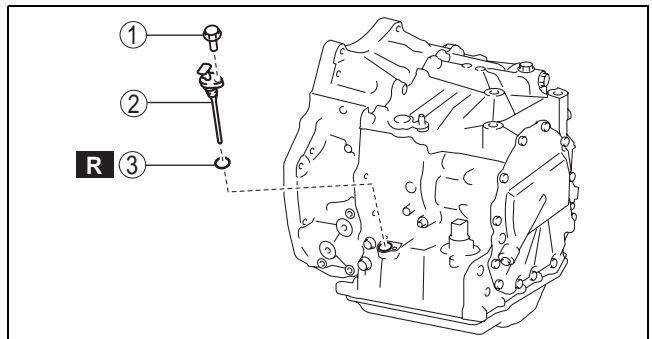

azzjw00000413

AUTOMATIC TRANSAXLE

6. Remove the hose clamp.

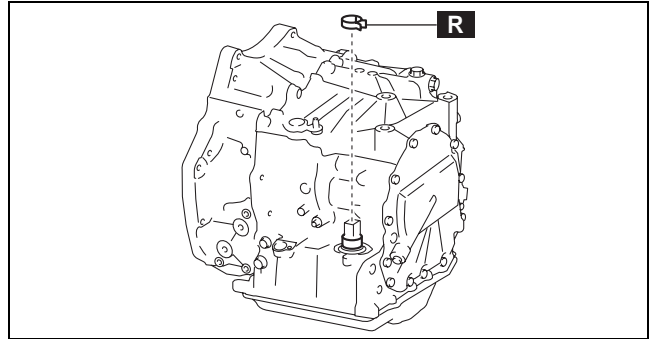

azzjw00000414

05-17

7. Install the transaxle to the SST (engine stand) using the following procedure:

Caution

- When installing the transaxle to the SST (engine stand) using chain hoists, be careful not to allow the transaxle to contact the SST (engine stand). If the transaxle contacts the SST, check the areas that made contact and replace damaged parts with new ones.

(1) Install the SSTs to the transaxle using the following procedure.

Note

- When installing the SST (49 L010 1A0) to the transaxle (stud bolt holes), use part number: 9YA02 1440 or M14×1.5 bolts, length to 100 mm {3.94 in}.
- When installing the SST (49 UN30 3050) to the transaxle, use part number: 9YA02 1015, or M10×1.5 bolts, length to 35 mm {1.4 in}.

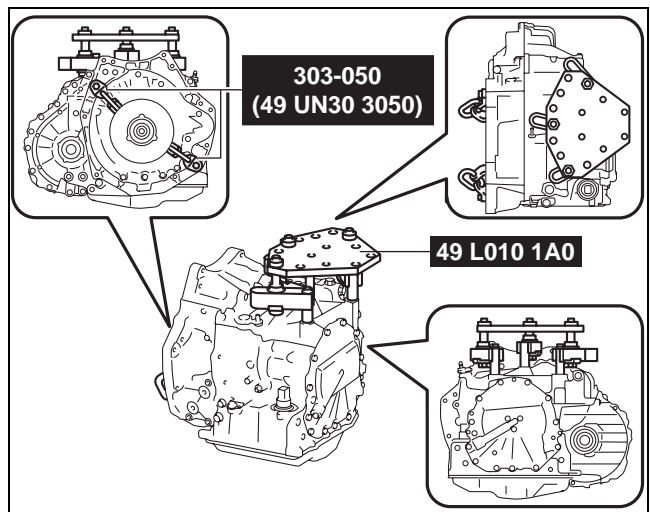

azzjw00000415

1) Temporarily install the arms (49 L010 102) using part number: 9YA02 1440, or M14×1.5 bolts, length to 100 mm {3.94 in}.

A : Part number: 9YA02 1440, or M14×1.5 bolt, length to 100 mm {3.94 in}

Note

- To adjust the installation position of the SST in Step 3), temporarily tighten the bolts.

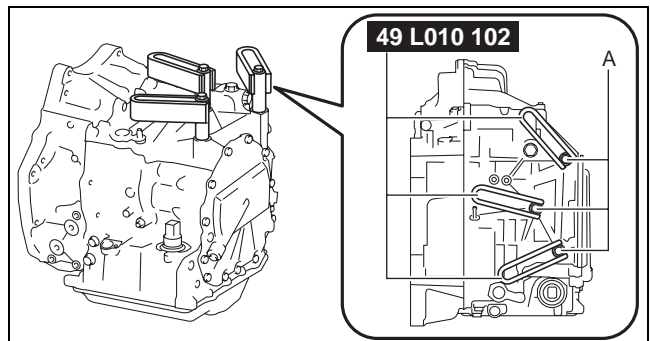

azzjw00000416

AUTOMATIC TRANSAXLE

2) Assemble the SST (49 L010 1A0).

- A : Washer
B : Approx. 20 mm {0.79 in}
C : Approx. 26 mm {1.0 in}
D : Approx. 47 mm {1.9 in}

Note

- Use bolts (49 L010 105) with a length of 138 mm {5.43 in}.

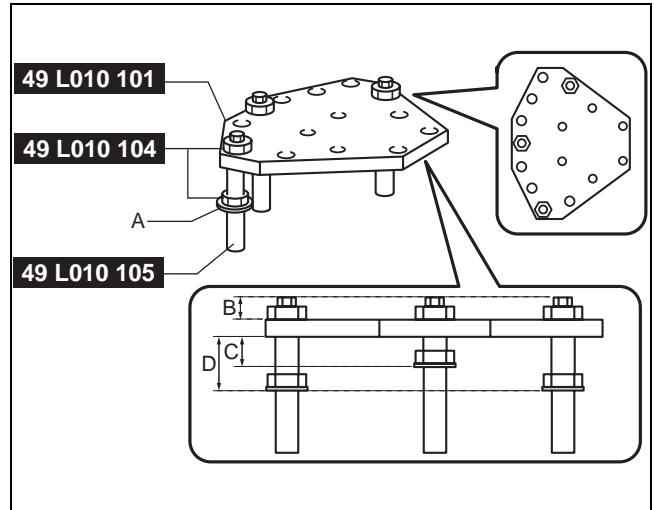

3) Install the SST assembled in Step 2).

- A : Washer
B : Level out

Note

- Adjust so that the plate (49 L010 101) and arms (49 L010 102) are level, and install.

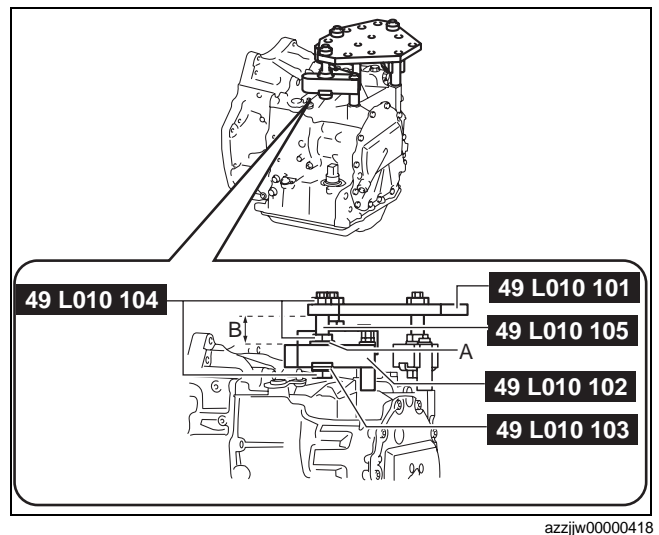

4) Verify that nothing other than the SST arms (49 L010 102) installation area contacts the transaxle.

Caution

- If something other than the SST arms (49 L010 102) installation area contacts the transaxle, readjust the SST to prevent damaging the part.

5) Tighten the nuts and bolts.

Tightening torque

- Bolt: Part number: 9YA02 1440, or M14×1.5 bolt, length to 100 mm {3.94 in}
40—52 N·m {4.1—5.3 kgf·m, 30—38 ft·lbf}
- Nut: 49 L010 104
140—160 N·m {15—16 kgf·m, 104—118 ft·lbf}

AUTOMATIC TRANSAXLE

- 6) Assemble the SSTs using part number: 9YA02 1015, or M10×1.5 bolts, length to 35 mm {1.4 in}.

A : Part number: 9YA02 1015, or M10×1.5 bolt, length to 35 mm {1.4 in}

Tightening torque

38—52 N·m {3.9—5.3 kgf·m, 29—38 ft·lbf}

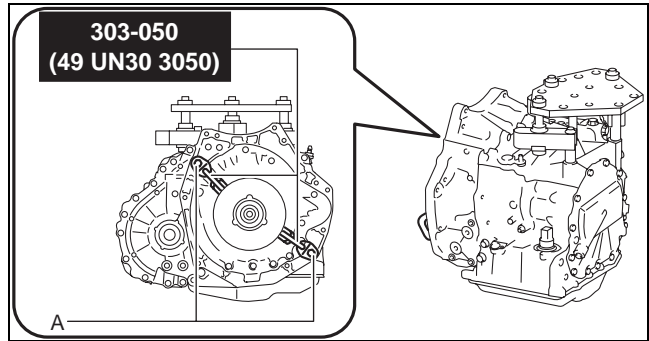

05-17

- (2) Using chain hoists, install the transaxle to the SST (engine stand) using part number: 9YA02 A220, or M12×1.75 bolts, length to 40 mm {1.6 in}.

A : Part number: 9YA02 A220, or M12×1.75 bolt, length to 40 mm {1.6 in}

Caution

- When installing the transaxle to the SST (engine stand) using chain hoists, be careful not to allow the transaxle to contact the SST (engine stand). If the transaxle contacts the SST, check the areas that made contact and replace damaged parts with new ones.

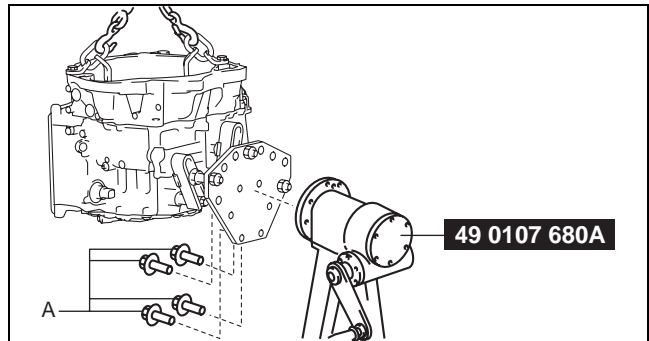

Note

- Tighten the four locations with bolts and securely install the transaxle to the SST (engine stand).

Tightening torque

88—118 N·m {9.0—12 kgf·m, 65—87 ft·lbf}

- (3) Remove the SSTs.

A : Part number: 9YA02 1015, or M10×1.5 bolt, length to 35 mm {1.4 in}

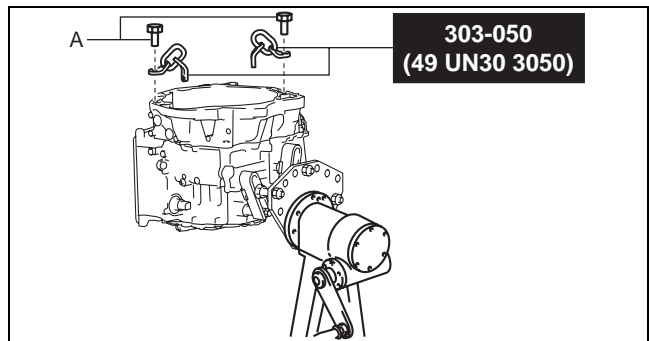

AUTOMATIC TRANSAXLE

8. Remove the oil pan and magnet using the following procedure:

1	16 bolts
2	Oil pan
3	Magnet

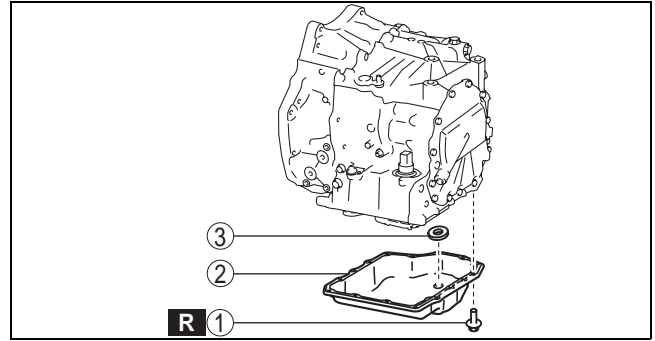

azzjw00001425

(1) Remove the bolts shown in the figure.

Caution

- If the removed bolts with spring washers are reused it could loosen the bolts due to spring weakness, therefore when performing the automatic transaxle assembly, use new bolts.

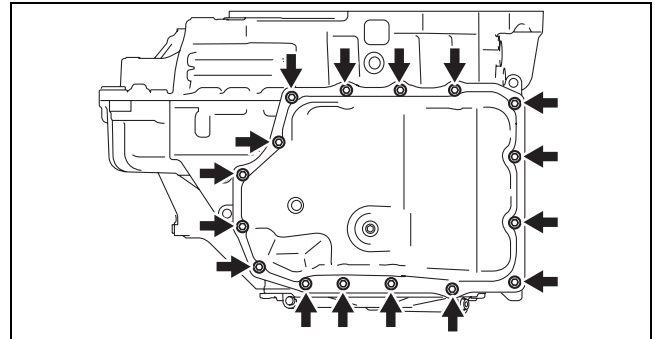

azzjw00000423

(2) Remove the oil pan using the separator tool.

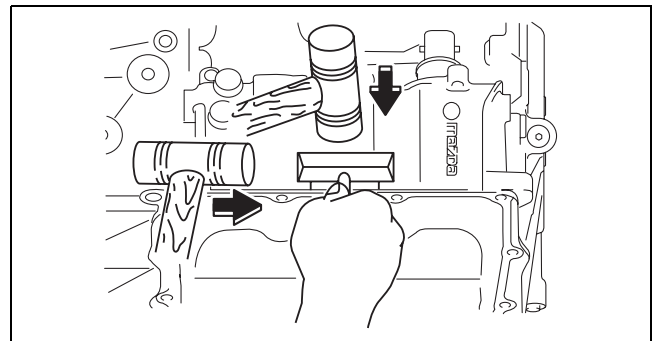

azzjw00000424

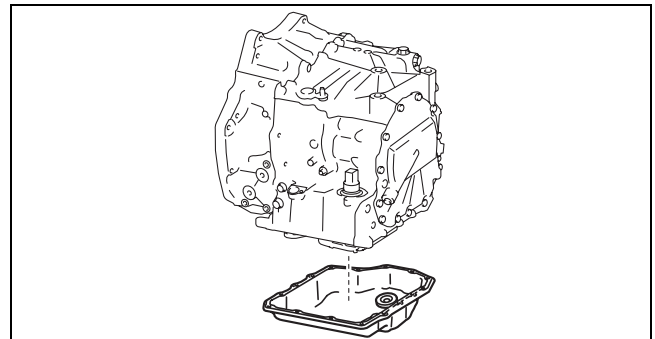

azzjw00000425

AUTOMATIC TRANSAXLE

(3) Remove the magnet.

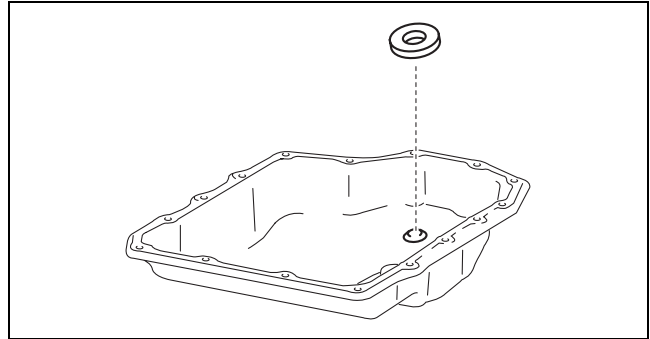

azzjw00000426

05-17

9. Remove the oil strainer in the order shown in the figure..

1	Bolt
2	Oil strainer

Caution

- If the oil strainer is reused while containing excessive foreign matter, it could cause an operation malfunction, therefore when performing the automatic transaxle assembly, use a new oil strainer.

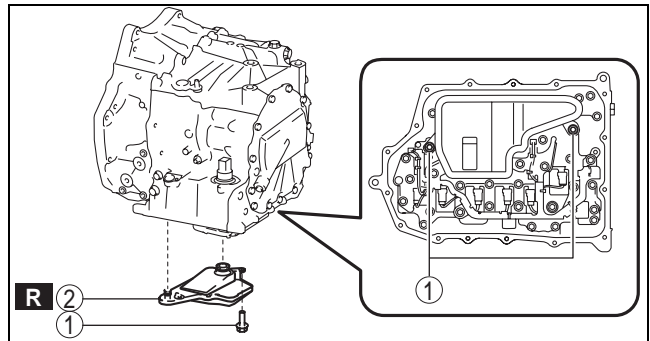

azzjw00001600

10. Remove the control valve body using the following procedure:.

1	11 bolts
2	Control valve body
3	Dowel pin
4	Gasket

Caution

- Place the removed control valve body with the TCM side pointing upward on a workbench. If placing it with the TCM side pointing downward on a workbench, the TCM could be damaged.
- Do not drop or apply an impact to the control valve body. Replace the control valve body with a new one if it was dropped or received an impact.

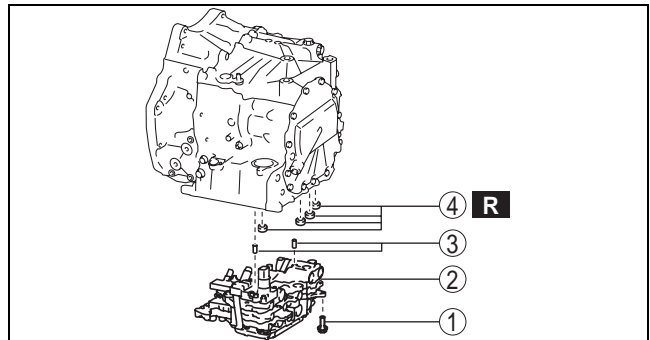

azzjw00000428

(1) Remove the bolts shown in the figure.

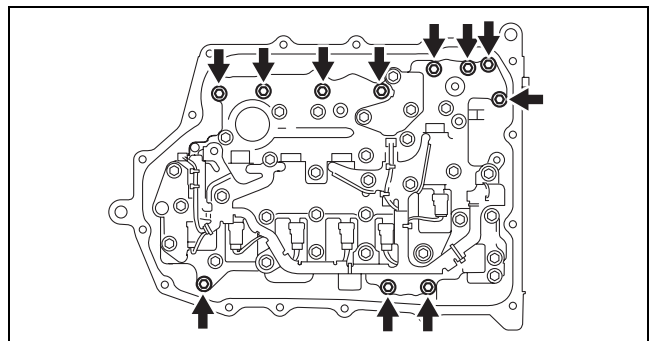

azzjw00000429

AUTOMATIC TRANSAXLE

(2) Remove the control valve body.

Caution

- Remove the control valve body straight so that force is not applied to the control valve body connector in the lateral direction.

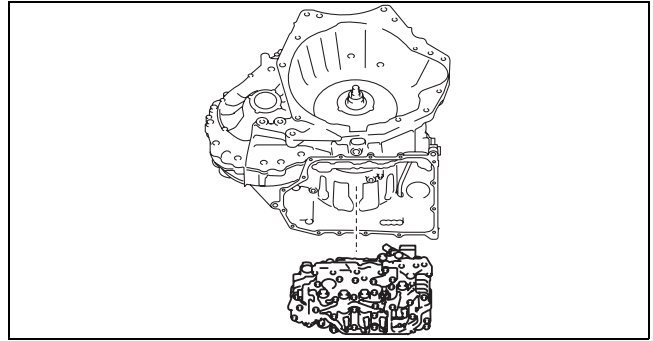

azzjw00000430

(3) Place the removed control valve body with the TCM side pointing upward on a workbench.

A : TCM

Caution

- Place the removed control valve body with the TCM side pointing upward on a workbench. If placing it with the TCM side pointing downward on a workbench, the TCM could be damaged.

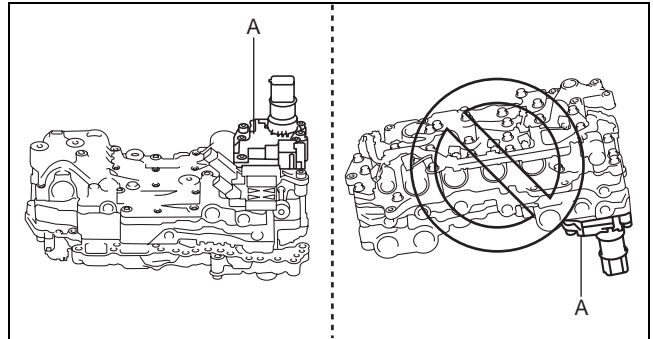

azzjw00000431

(4) Remove the dowel pins.

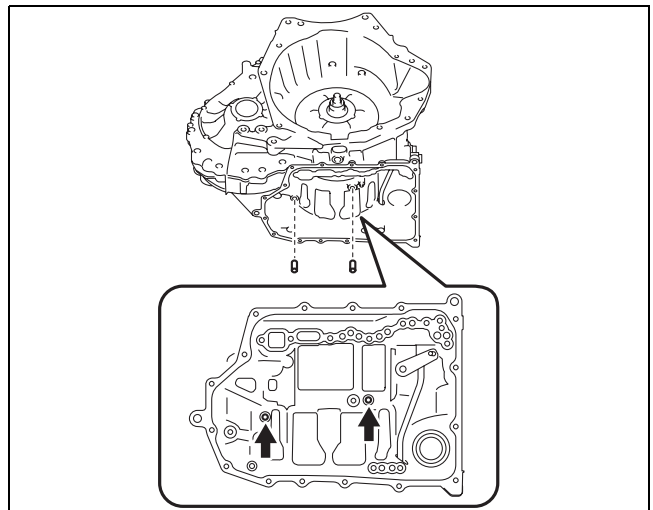

azzjw00000432

AUTOMATIC TRANSAXLE

(5) Remove the gaskets.

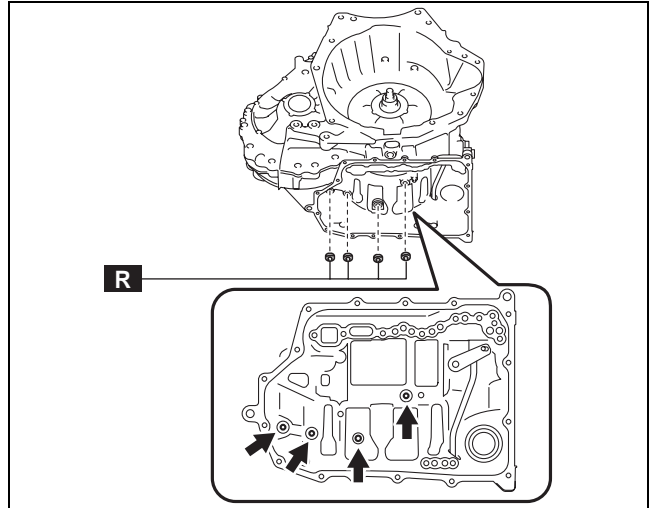

azzjjw00000433

05-17

11. Remove the oil seal.

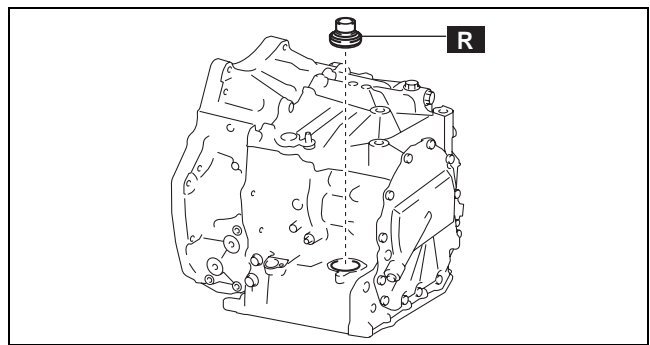

azzjjw00000434

12. Remove the converter housing using the following procedure:

1	24 bolts
2	Converter housing
3	O-ring (oil pump)
4	O-ring (oil cooler oil passage)

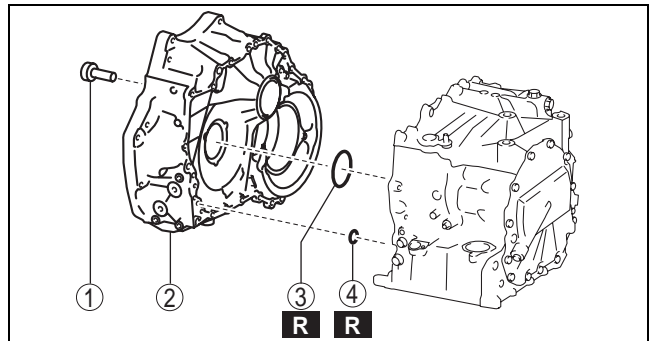

azzjjw00000435

(1) Remove the bolts shown in the figure.

Caution

- Sealant has been applied to the removed bolts. If the bolts are reused it could cause ATF leakage, therefore when performing the automatic transaxle assembly, use new bolts.

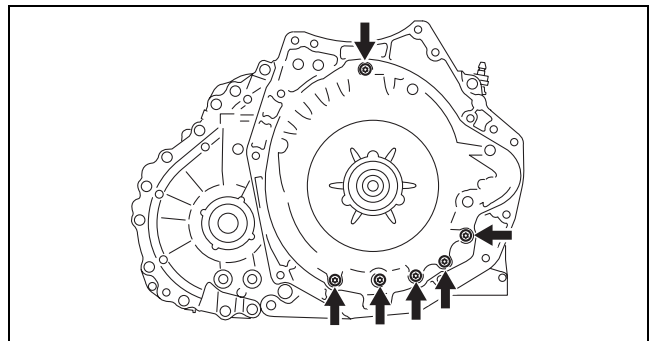

azzjjw00000436

AUTOMATIC TRANSAXLE

(2) Remove the bolts shown in the figure.

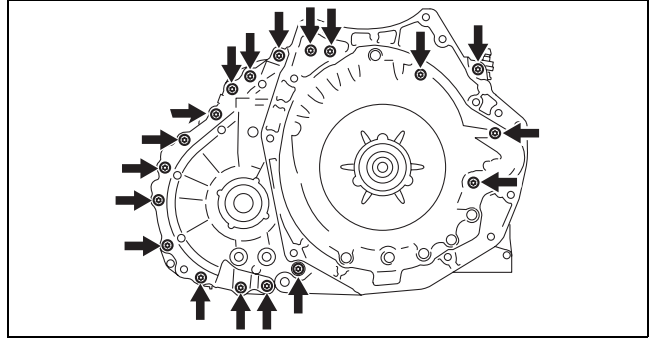

azzjw00000437

(3) Lightly tap the converter housing using a plastic hammer to remove it.

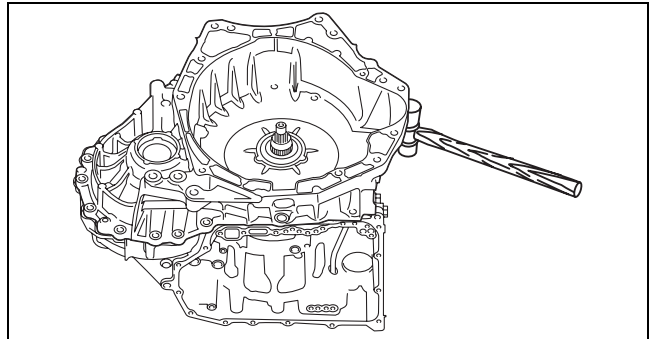

azzjw00000438

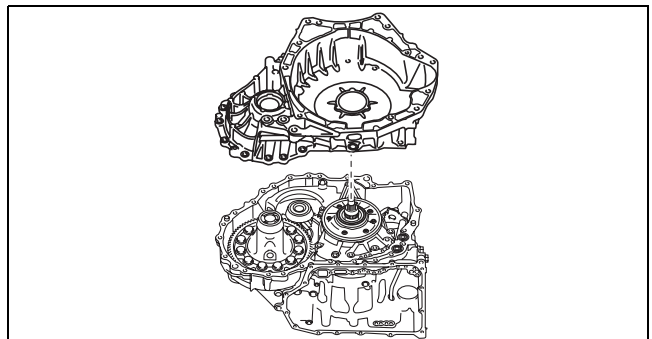

azzjw00000439

(4) Remove the O-rings.

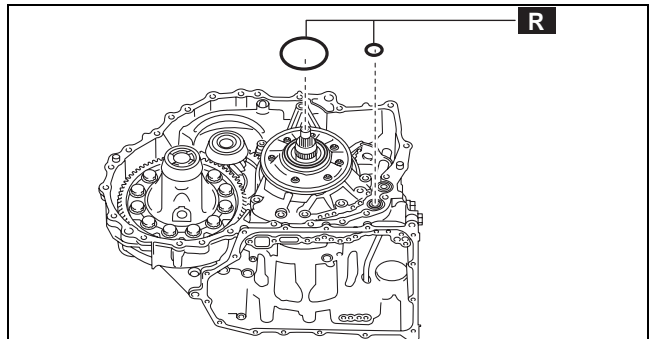

azzjw00000440

AUTOMATIC TRANSAXLE

13. Remove the accessories from the converter housing using the following procedure:

(1) Remove the baffle plate using the procedure shown in the figure.

1	Bolt
2	Baffle plate

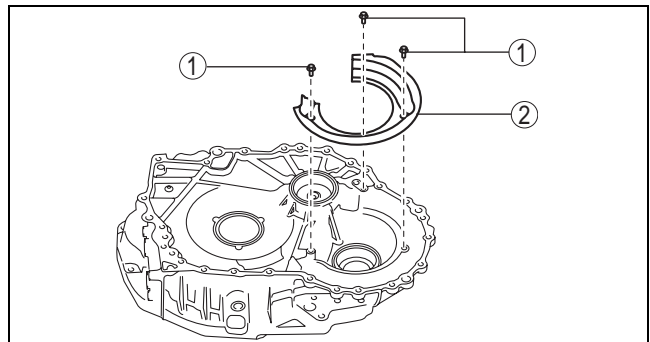

azzjw00000441

(2) Remove the oil seal.

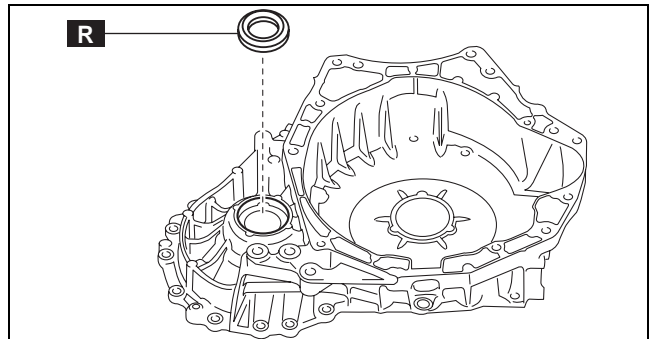

azzjw00000442

(3) Remove the bearing race and shim using the SSTs and procedure shown in the figure.

Caution

- Because the shim will deform when removing the bearing race, use a new shim when performing the automatic transaxle assembly.

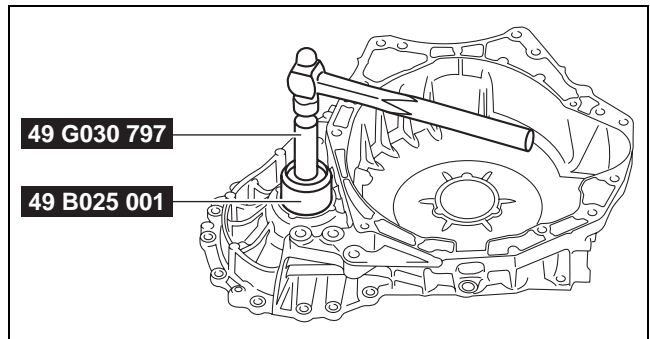

azzjw00000443

1	Bearing race
2	Shim

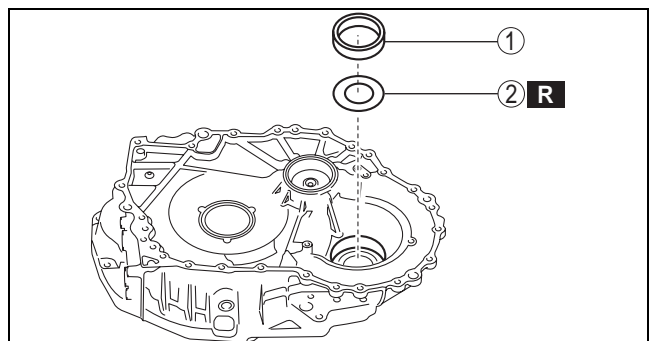

azzjw00000444

AUTOMATIC TRANSAXLE

(4) Remove the bearing race and shim using the SST and procedure shown in the figure.

Caution

- Because the shim will deform when removing the bearing race, use a new shim when performing the automatic transaxle assembly.

1	Bearing race
2	Shim

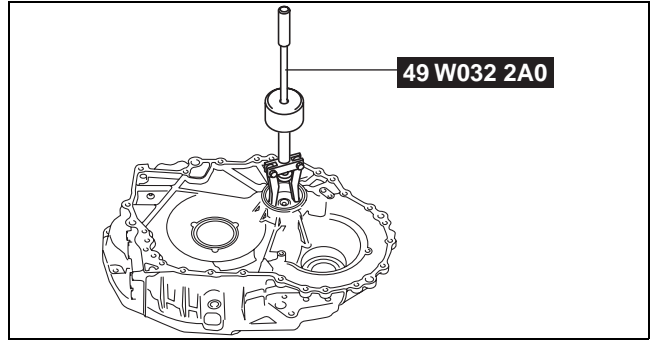

azzjw00000445

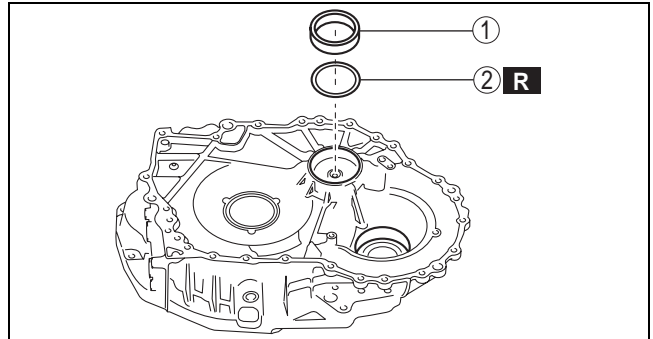

azzjw00000446

14. Remove the baffle plate.

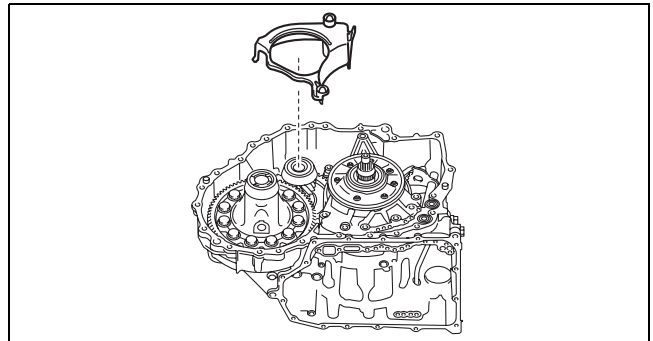

azzjw00000447

15. Remove the oil pump using the following procedure:

1	7 bolts
2	Oil pump

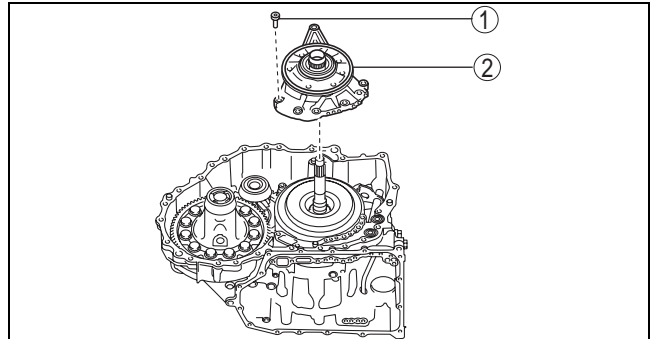

azzjw00000448

AUTOMATIC TRANSAXLE

(1) Remove the bolts shown in the figure.

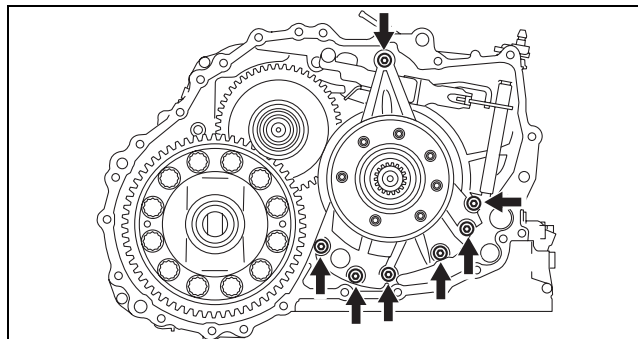

azzjw00000449

05-17

(2) Remove the oil pump.

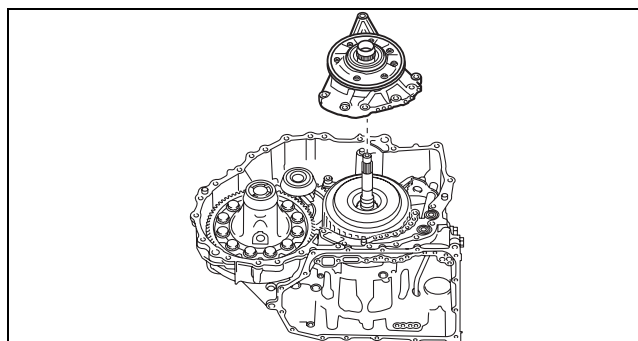

azzjw00000450

16. Remove the thrust needle bearing.

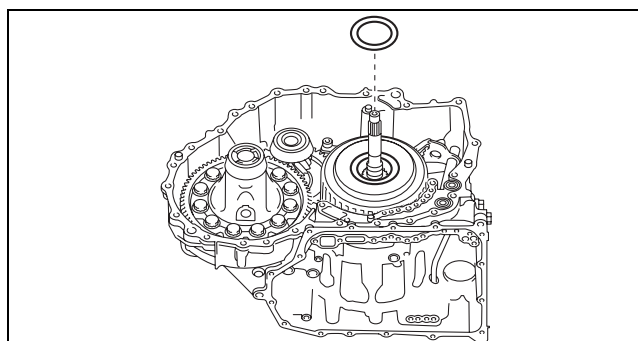

azzjw00000451

17. Remove the clutch component.

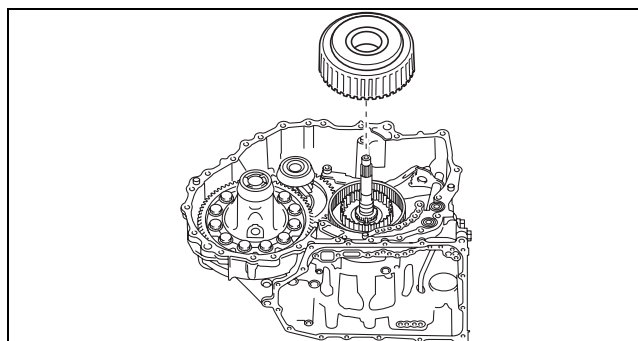

azzjw00000452

AUTOMATIC TRANSAXLE

18. Remove the turbine shaft.

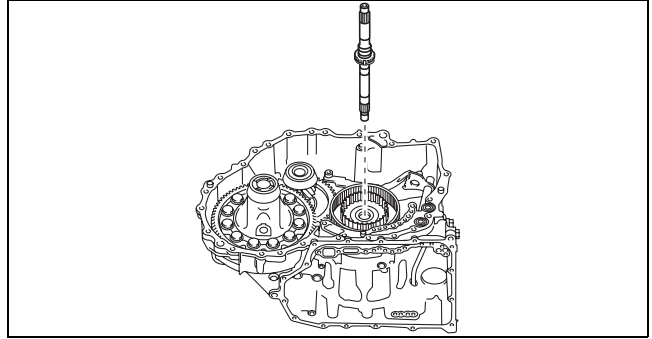

azzjw00000453

19. Remove the D-ring and seal rings from the turbine shaft using the procedure in the figure:

1	D-ring
2	Seal ring

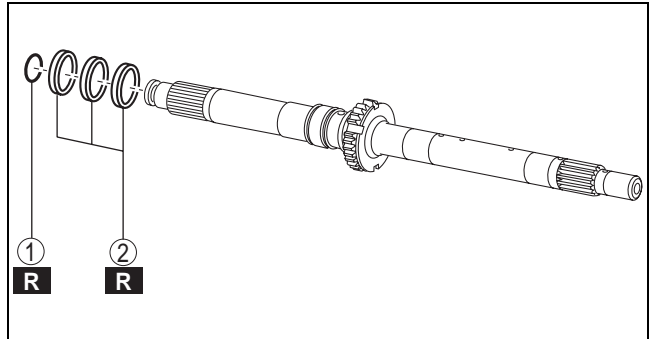

azzjw00000454

20. Remove the thrust needle bearing.

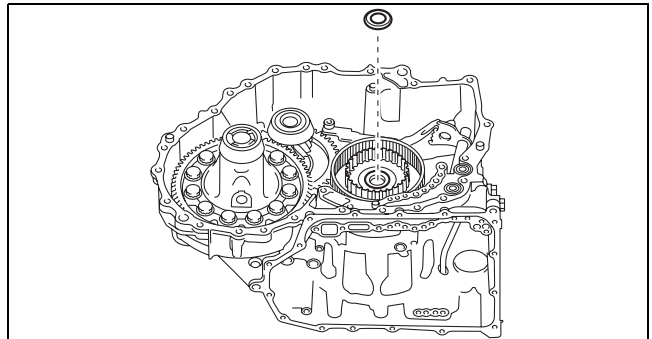

azzjw00000455

21. Remove the high clutch hub.

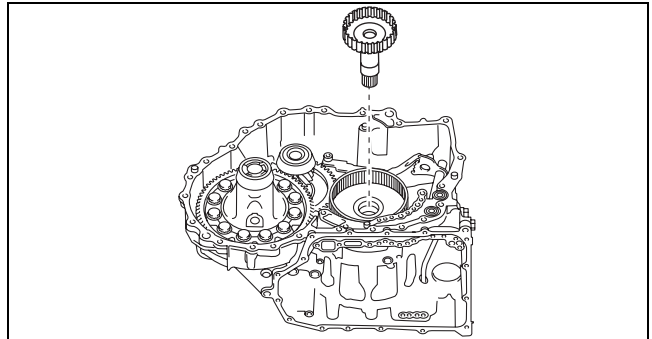

azzjw00000456

AUTOMATIC TRANSAXLE

22. Remove the thrust needle bearing.

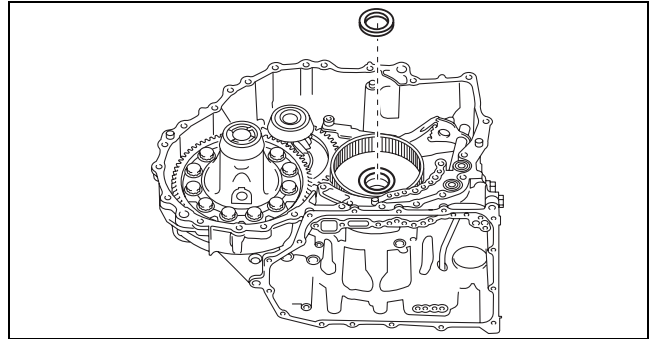

azzjw00000457

05-17

23. Remove the low clutch hub.

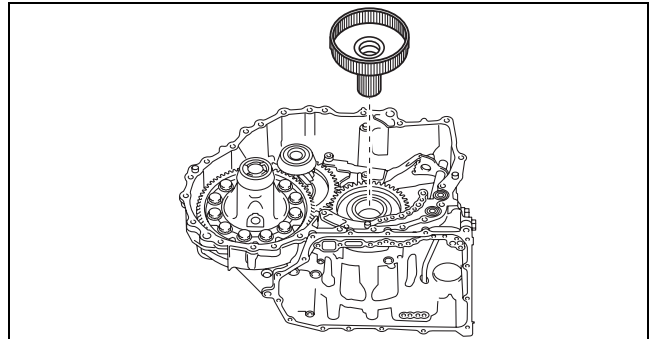

azzjw00000458

24. Remove the thrust needle bearing.

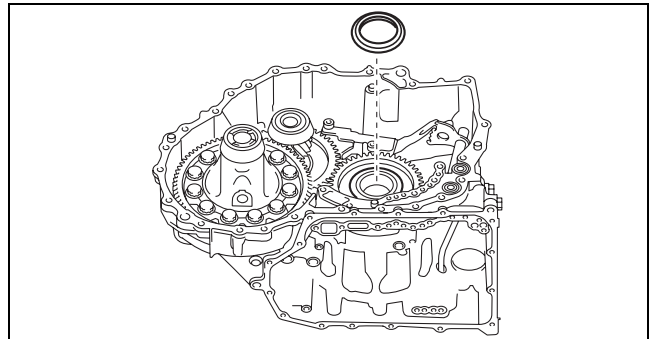

azzjw00000459

25. Remove the ring gear and differential.

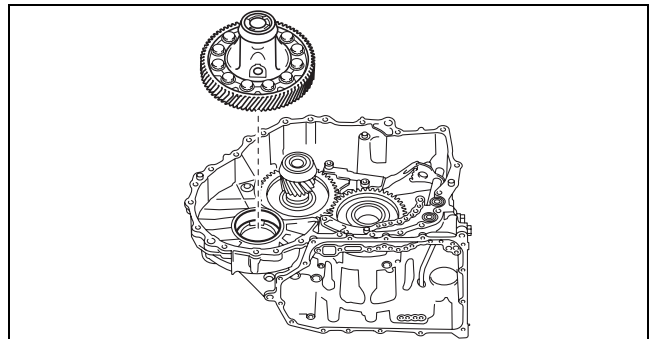

azzjw00000460

AUTOMATIC TRANSAXLE

26. Remove the oil pipe.

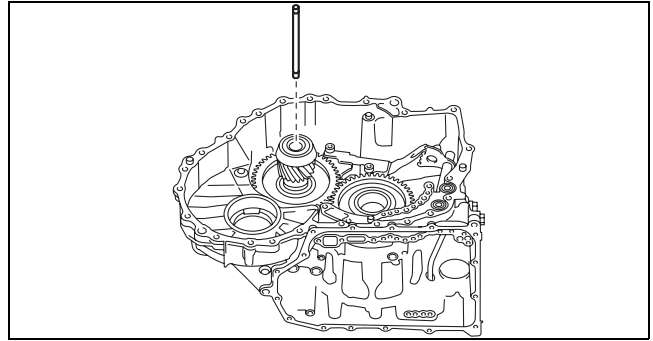

azzjiw00000461

27. Remove the secondary gear and output gear.

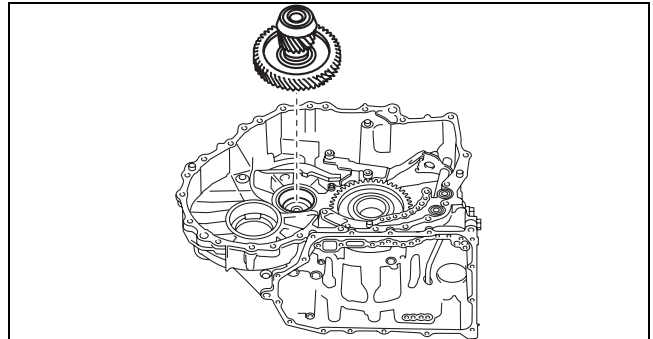

azzjiw00000462

28. Remove the baffle plate using the procedure shown in the figure..

1	Bolt
2	Baffle plate

Caution

- The bolts for the baffle plate assembly are applied with thread-locking compound. If the bolts are reused it could loosen the bolts, therefore when performing the automatic transaxle assembly, use new bolts.

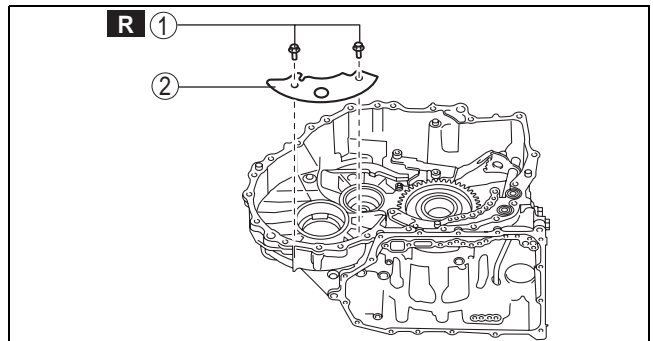

azzjiw00000463

29. Remove the oil seal.

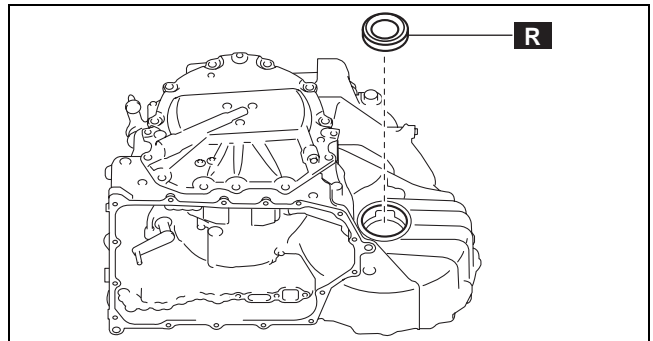

azzjiw00000464

AUTOMATIC TRANSAXLE

30. Remove the bearing race and shim using the following procedure:

- (1) When removing the bearing race and shim using the SST, place a rag as an impact-absorbing material on the oil catch area of the SST (engine stand) because the bearing race and shim will drop when removed.

A : Impact-absorbing material (rag)

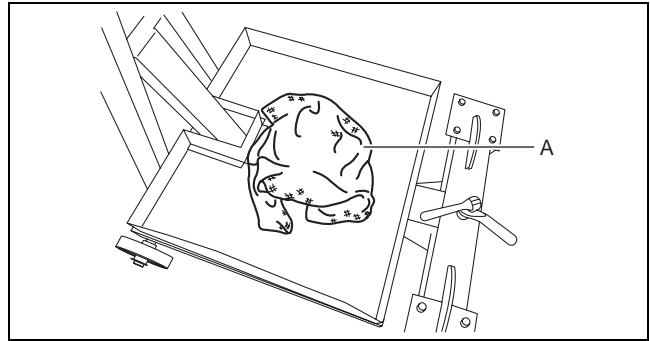

azzjw00000465

- (2) Remove the bearing race and shim using the SSTs and procedure shown in the figure.

Caution

- Because the shim will deform when removing the bearing race, use a new shim when performing the automatic transaxle assembly.

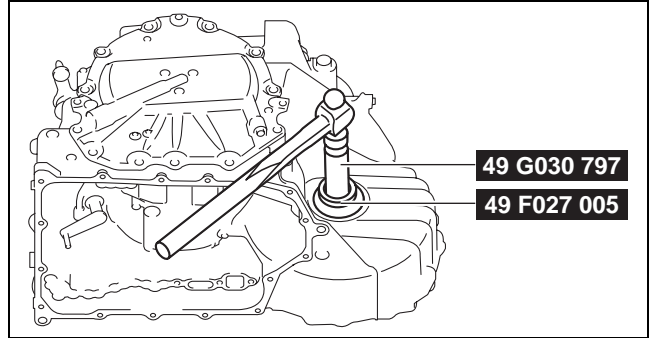

azzjw00000466

1	Bearing race
2	Shim

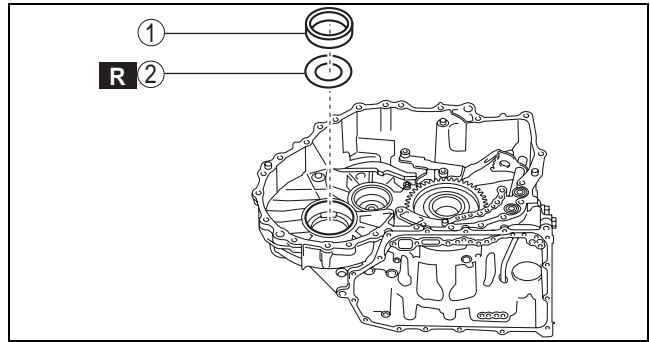

azzjw00000467

- (3) Remove the rag placed on the oil catch area of the SST (engine stand) used as an impact-absorbing material.

05-17

AUTOMATIC TRANSAXLE

31. Remove the bearing race using the SST.

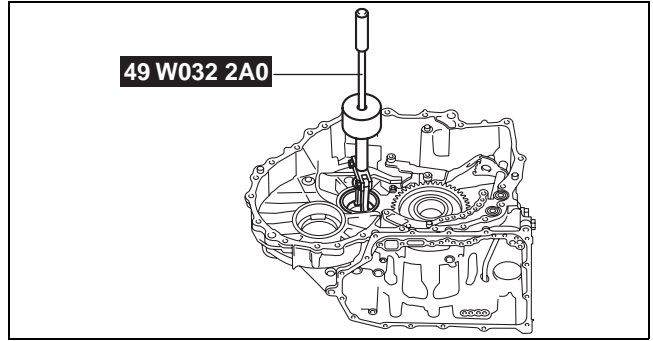

azzjw00000468

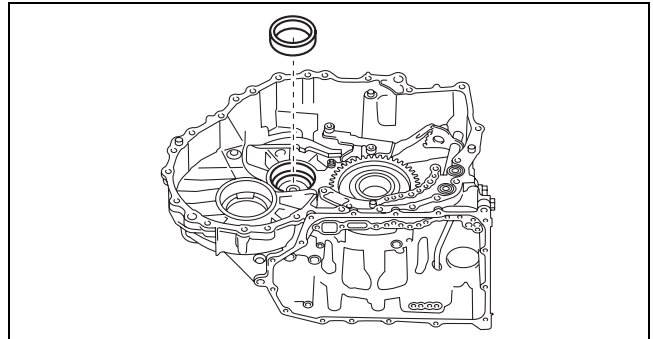

azzjw00000469

32. Remove end cover component using the following procedure:

1	12 bolts
2	End cover component
3	O-ring

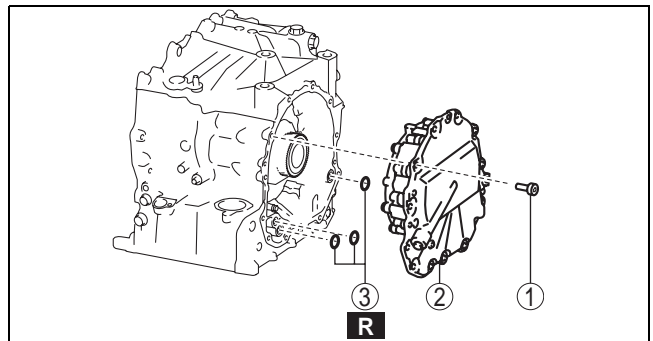

azzjw00000470

(1) Remove the bolts shown in the figure.

Caution

- Sealant has been applied to the removed bolts. If the bolts are reused it could cause ATF leakage, therefore when performing the automatic transaxle assembly, use new bolts.

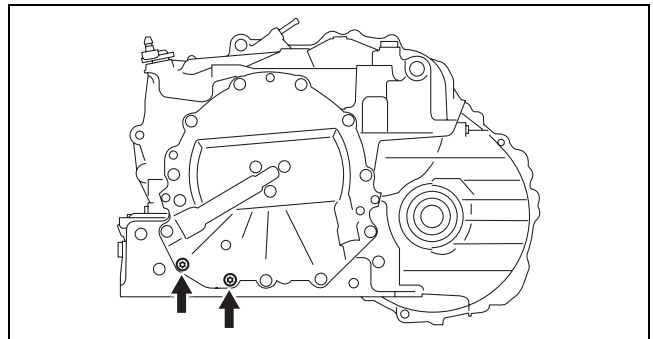

azzjw00000471

AUTOMATIC TRANSAXLE

(2) Remove the bolts shown in the figure.

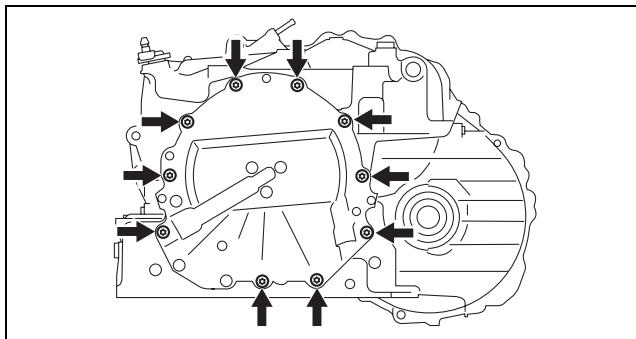

azzjjw00000472

(3) Lightly tap the end cover component using a plastic hammer to remove it.

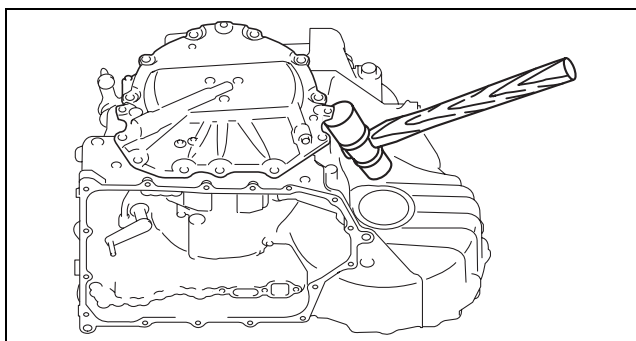

azzjjw00000473

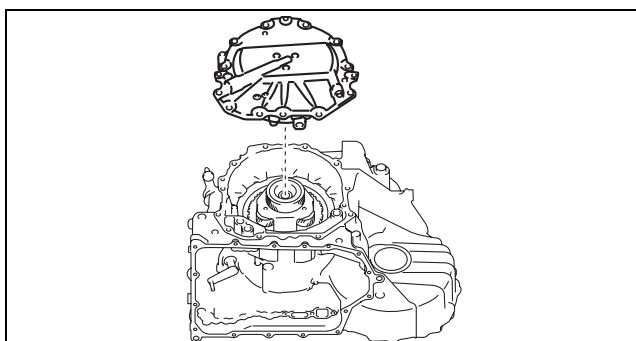

azzjjw00000474

(4) Remove the O-rings.

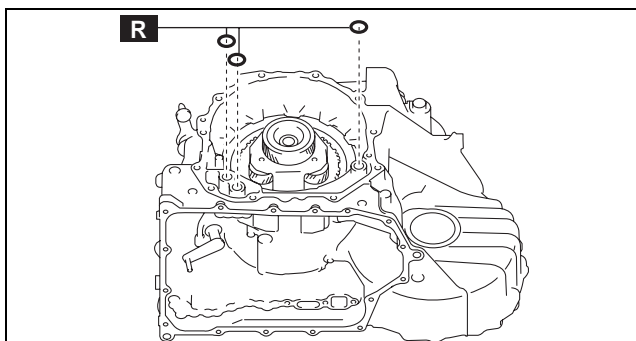

azzjjw00000475

05-17

AUTOMATIC TRANSAXLE

33. Remove the shim.

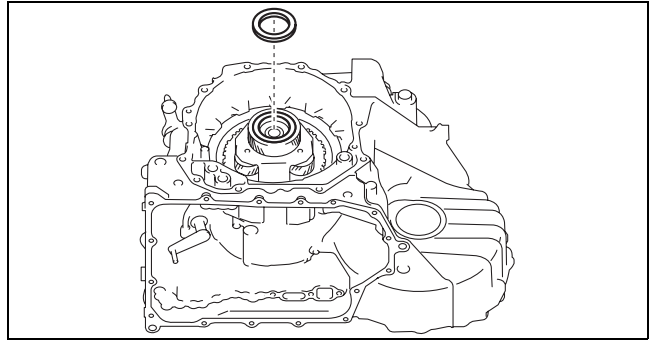

azzjw00000476

34. Remove the thrust needle bearing.

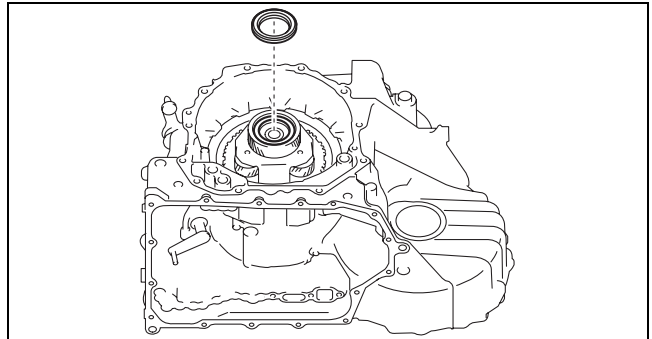

azzjw00000477

35. Remove the reduction sun gear.

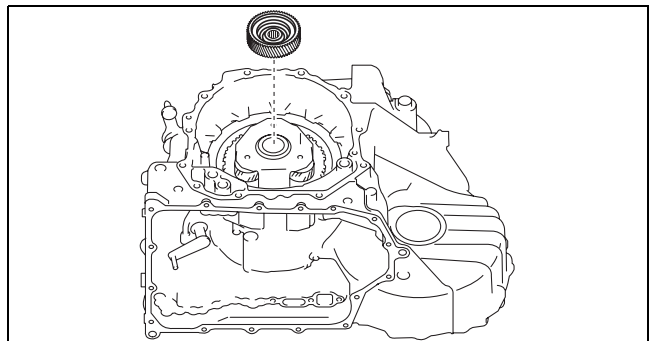

azzjw00000478

36. Remove the thrust needle bearing.

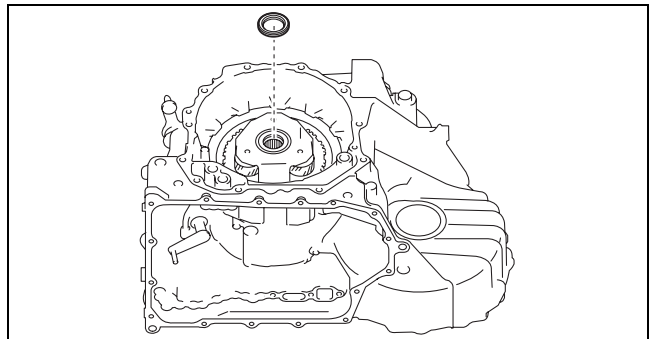

azzjw00000479

AUTOMATIC TRANSAXLE

37. Remove the rear planetary gear.

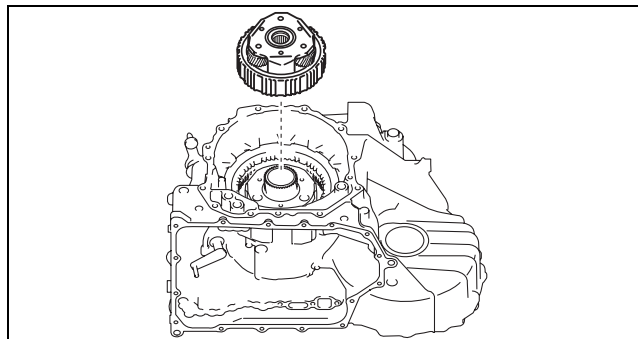

azzjw00000480

38. Remove the rear sun gear.

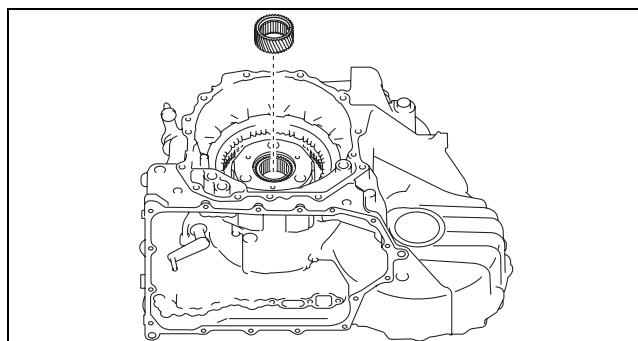

azzjw00000481

39. Remove the front sun gear.

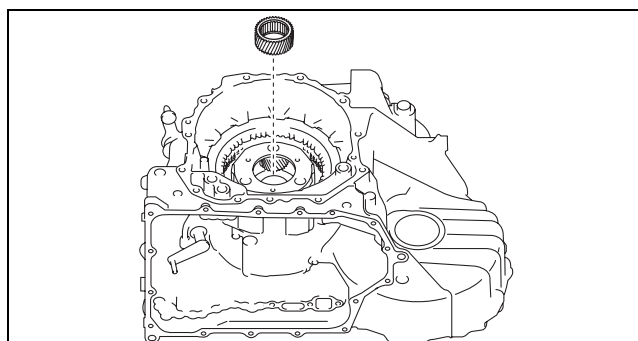

azzjw00000482

40. Inspect the transaxle case, primary gear, and the angular contact ball bearing using the following procedure:

- (1) Visually inspect the transaxle case and primary gear. (See 05-17-151 VISUAL INSPECTION OF PARTS.)
- (2) Rotate the primary gear by hand and verify that there is no malfunction in the angular contact ball bearing (rotation sticking).
 - If there is a malfunction, remove the primary gear in Step 63 and replace the malfunctioning parts with new ones as when performing the automatic transaxle assembly.

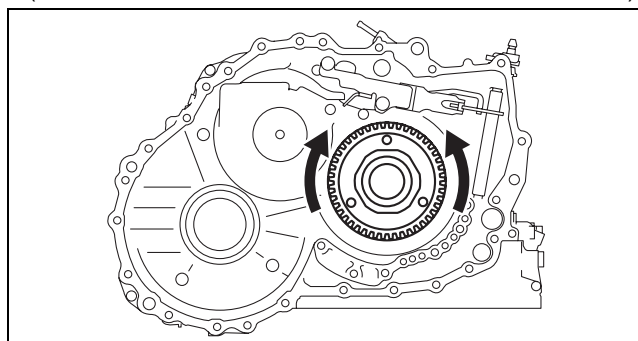

azzjw00000483

05-17

AUTOMATIC TRANSAXLE

41. Remove the locknut using the following procedure:

Caution

- Rotate and adjust the rotation handle of the engine stand so that the end cover side is situated sideways and remove the locknut. If the locknut is removed with the end cover side pointed downward, the front planetary gear will drop.
- Torque of approx. 500 N·m {51 kgf·m, 369 ft·lbf} is required to loosen the locknut. For safety purposes, perform the procedure using two people, one loosens the locknut and the other supports the engine stand.

- (1) Rotate and adjust the rotation handle of the engine stand so that the end cover side is situated sideways.

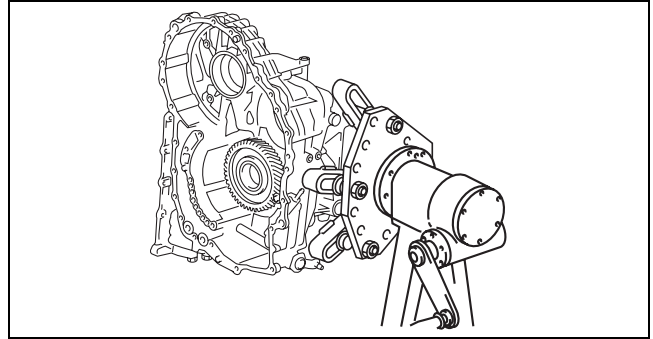

azzjiw00000484

- (2) Install the SSTs.

- A : Extension bar
B : Bolt supplied with SST (49 B019 029) or M8×1.25, length to 18 mm {0.71 in}

Note

- Engage the three projections of the SST (49 B019 028) to the three holes of the primary gear.
- When installing the SST (49 B019 029), use the bolts supplied with the SST (49 B019 029), or M8×1.25 bolts, length to 18 mm {0.71 in}.

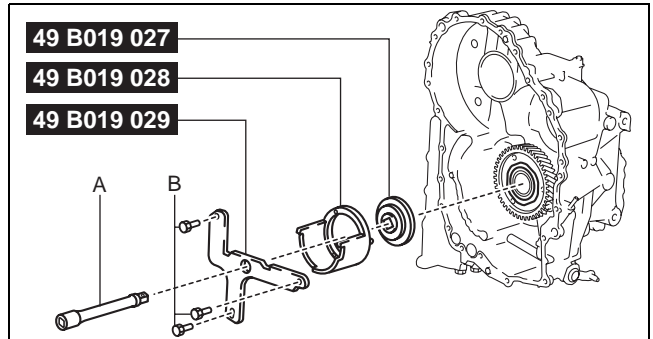

azzjiw00000485

- A : Extension bar
B : Bolt supplied with SST (49 B019 029) or M8×1.25, length to 18 mm {0.71 in}

SST installation bolt tightening torque
19—25 N·m {2.0—2.5 kgf·m, 15—18 ft·lbf}

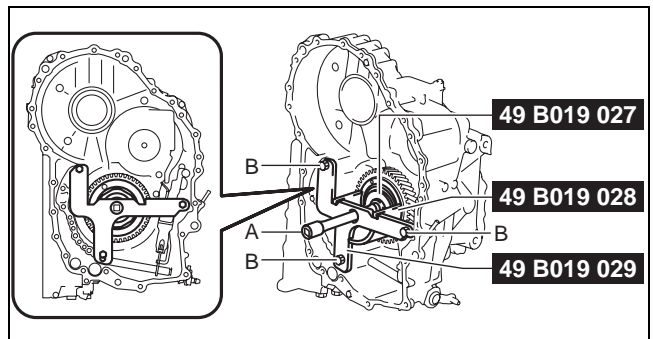

azzjiw00000486

AUTOMATIC TRANSAXLE

(3) Loosen the locknut and remove it.

Caution

- Torque of approx. 500 N·m {51 kgf·m, 369 ft·lbf} is required to loosen the locknut. For safety purposes, perform the procedure using two people, one loosens the locknut and the other supports the engine stand.

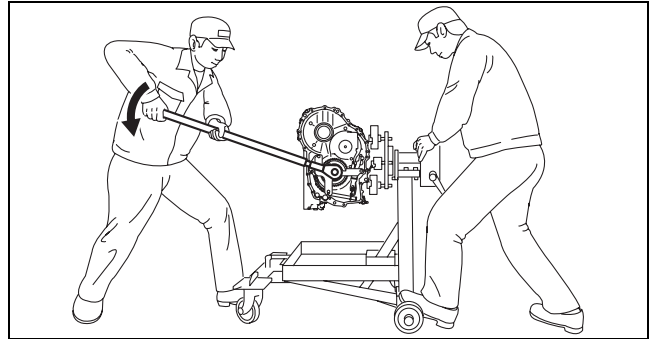

azzjw00000487

05-17

(4) Remove the SSTs.

- A : Extension bar
B : Bolt supplied with SST (49 B019 029) or M8×1.25, length to 18 mm {0.71 in}

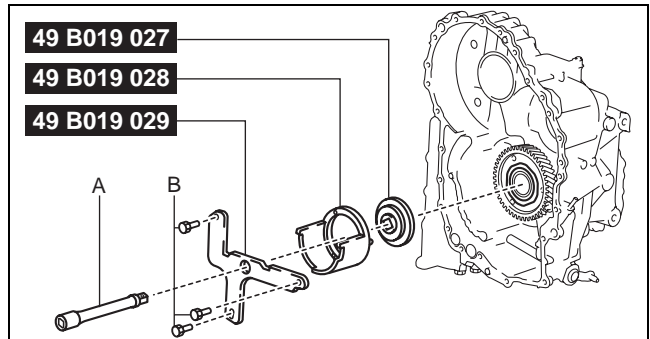

azzjw00000485

(5) Remove the locknut from the front planetary gear.

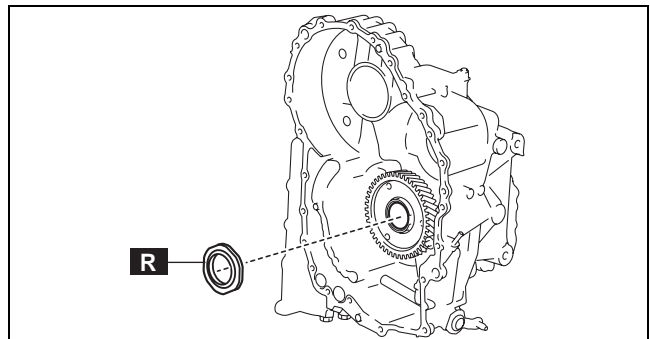

azzjw00000488

42. Remove the front planetary gear.

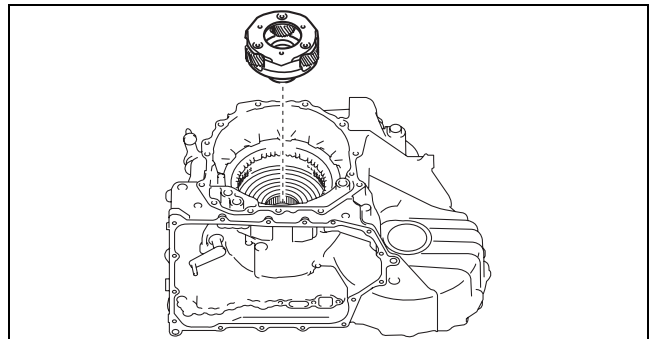

azzjw00000489

AUTOMATIC TRANSAXLE

43. Perform a simple inspection of the low and reverse brake using the following procedure:

- (1) Blow compressed air into the oil passage shown in the figure and verify the operation condition of the low and reverse brake.

Warning

- Always wear protective eye wear when using the air compressor. Otherwise, ATF or dirt particles blown off by the air compressor could get into the eyes.

Caution

- To prevent damage to parts, always use an air compressor which is adjusted to the indicated pressure.

Compressed air pressure

0.39—0.44 MPa {4.0—4.4 kgf/cm²,
57—63 psi}

- If there is a malfunction, verify the cause and repair the applicable part after disassembly.

44. Remove the snap ring using the following procedure:

- (1) Install the SSTs.

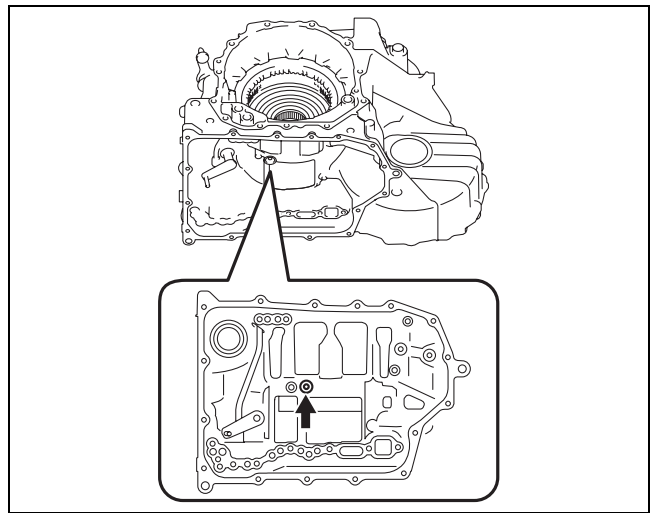

azzjiw00000490

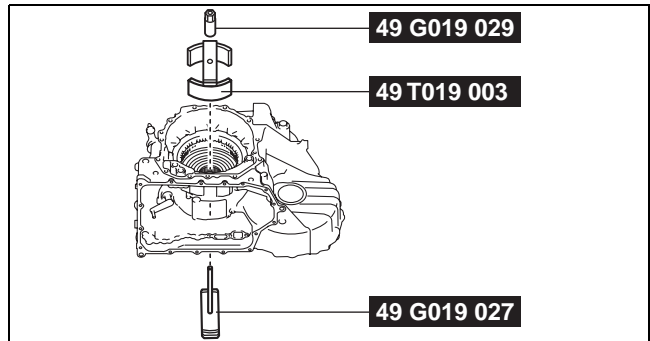

azzjiw00000491

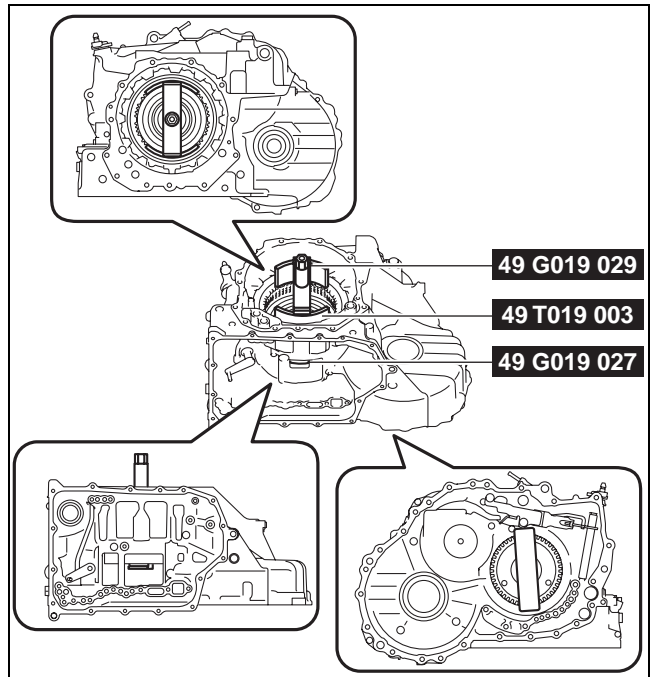

azzjiw00000492

AUTOMATIC TRANSAXLE

- (2) Tighten the SST (49 G019 029) until there is no longer any spring force from the springs and retainer component applied to the snap ring.

A : Snap ring
B : One-way clutch
C : Gap

Caution

- If the SST (49 G019 029) is tightened with excessive force, surrounding parts could be damaged. Stop tightening if a gap appears between the snap ring and one-way clutch.

Note

- Lock the SST (49 G019 027) against rotation using a flathead screwdriver and tighten the SST (49 G019 029).

- (3) Remove the snap ring.

- (4) Loosen the SST (49 G019 029) and remove the SSTs.

Note

- Lock the SST (49 G019 027) against rotation using a flathead screwdriver and loosen the SST (49 G019 029).

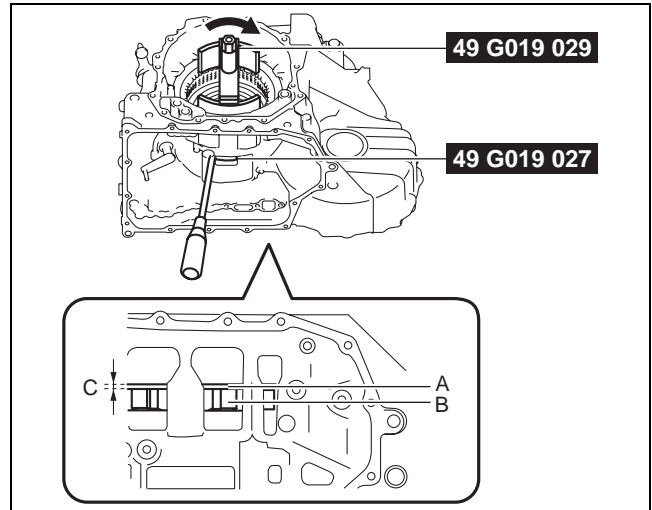

azzjjw00000493

05-17

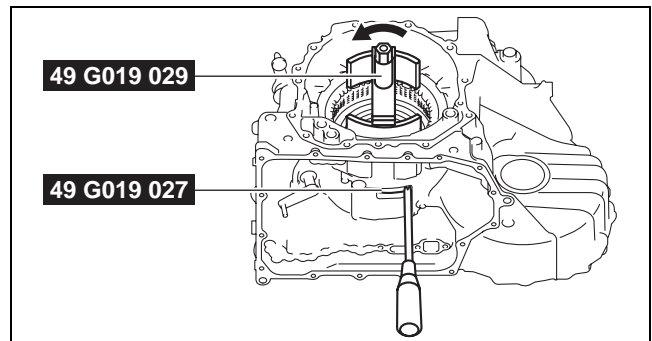
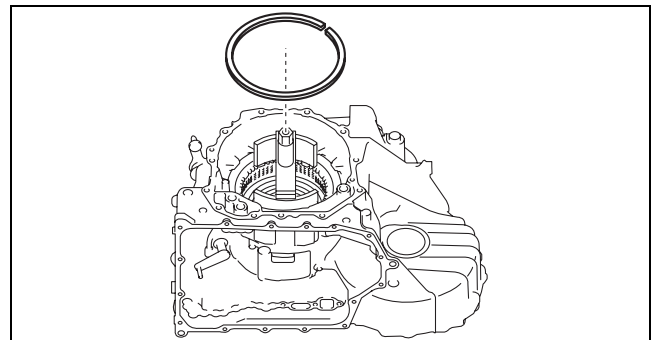

azzjjw00000495

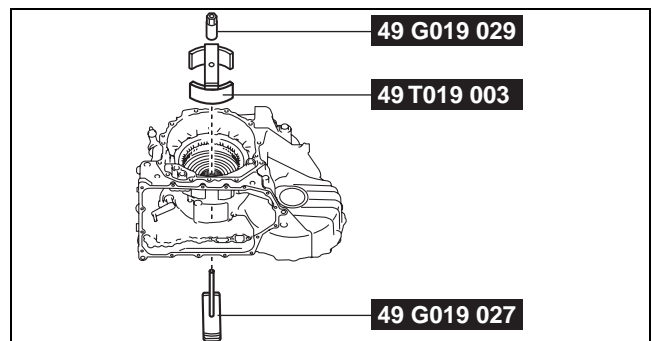

azzjjw00000491

AUTOMATIC TRANSAXLE

45. Remove the one-way clutch.

Caution

- Do not disassemble the one-way clutch. If it has been disassembled, replace the one-way clutch with a new one.

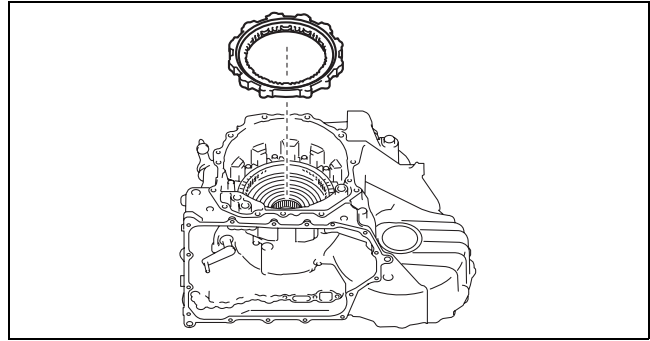

azzjiw00000496

46. Remove the drive plates and driven plates.

- A : Drive plate
B : Driven plate

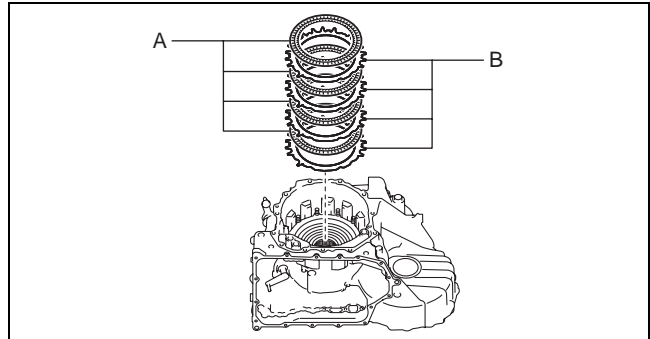

azzjiw00000497

47. Remove the springs and retainer component.

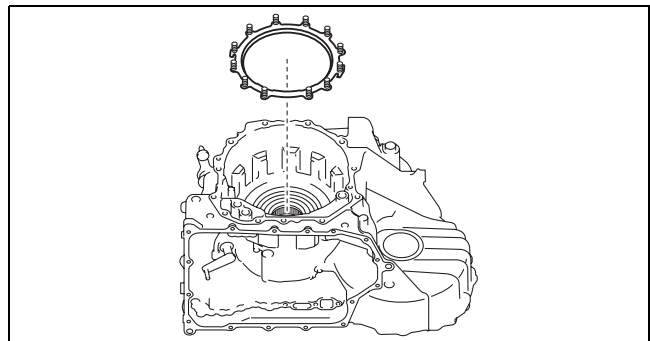

azzjiw00000498

48. Remove the low and reverse brake piston using the following procedure:

- (1) Blow compressed air into the oil passage shown in the figure.

Warning

- Always wear protective eye wear when using the air compressor. Otherwise, ATF or dirt particles blown off by the air compressor could get into the eyes.

Caution

- To prevent damage to parts, always use an air compressor which is adjusted to the indicated pressure.

Compressed air pressure

0.39—0.44 MPa {4.0—4.4 kgf/cm²,
57—63 psi}

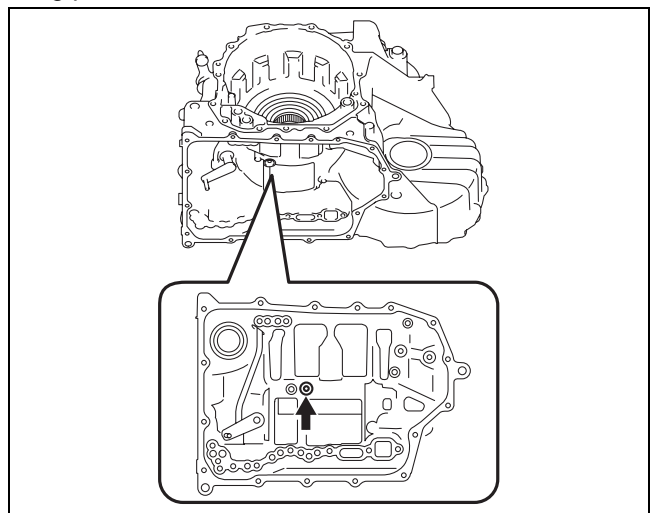

azzjiw00000499

AUTOMATIC TRANSAXLE

(2) Remove the low and reverse brake piston removed from the transaxle case.

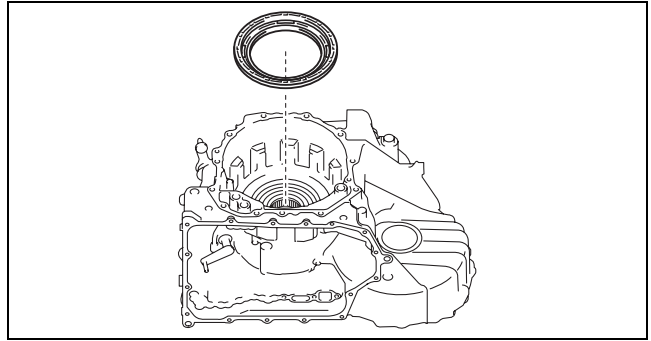

azzjw00000500

05-17

49. Remove the connector, gaskets, oil pipe, and the O-rings in the order shown in the figure.

1	Connector
2	Gasket
3	Oil pipe
4	O-ring

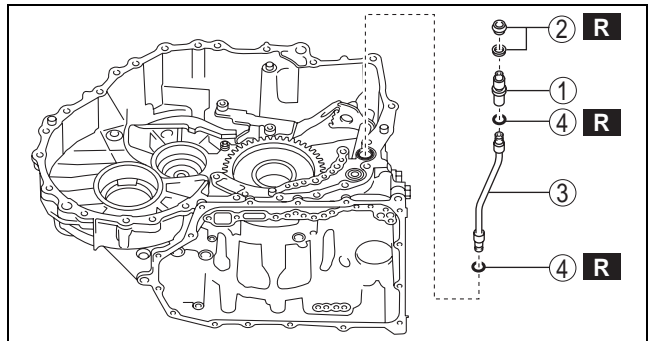

azzjw00000501

50. Remove the detent bracket component in the order shown in the figure.

1	Bolt
2	Detent bracket component

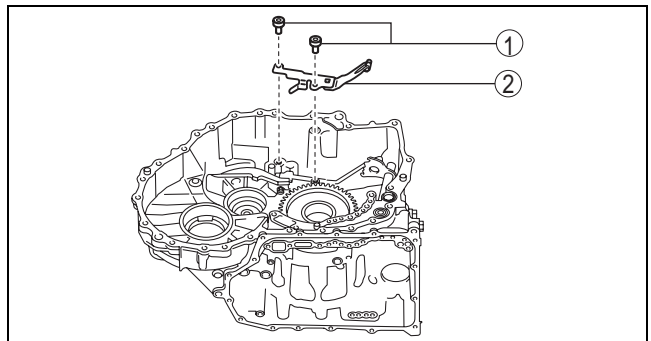

azzjw00000502

51. Remove the pawl return springs.

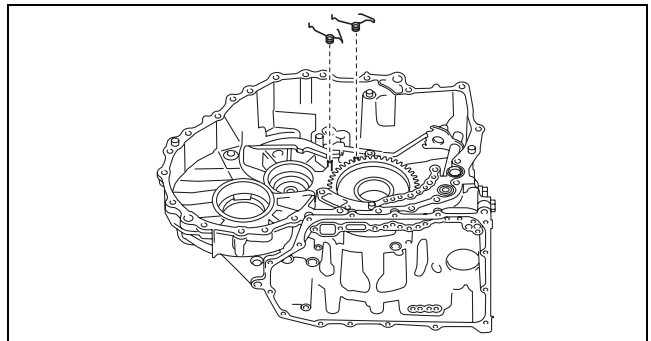

azzjw00000503

AUTOMATIC TRANSAXLE

52. Remove the support actuator.

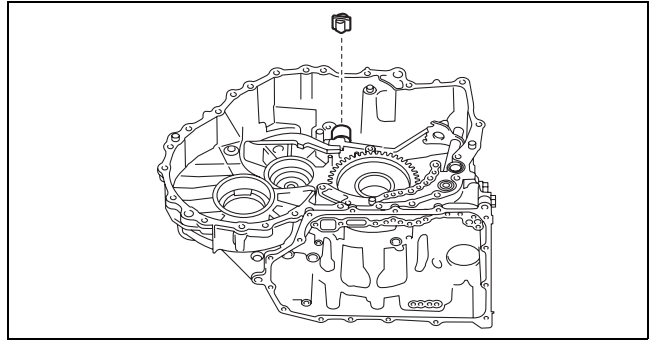

azzjw00000504

53. Remove the parking pawl pin.

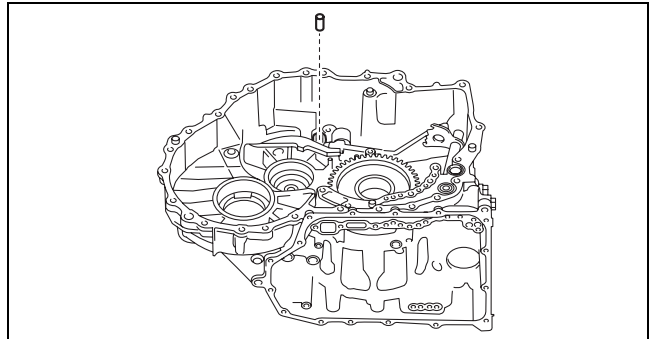

azzjw00000505

54. Remove the parking rod component using the following procedure:

- (1) Rotate the parking rod component as shown in the figure and align the parking rod component projection with the keyhole of the manual plate component.

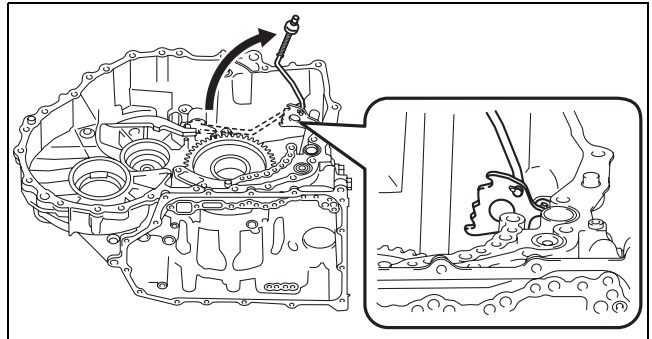

azzjw00000506

- (2) Remove the parking rod component.

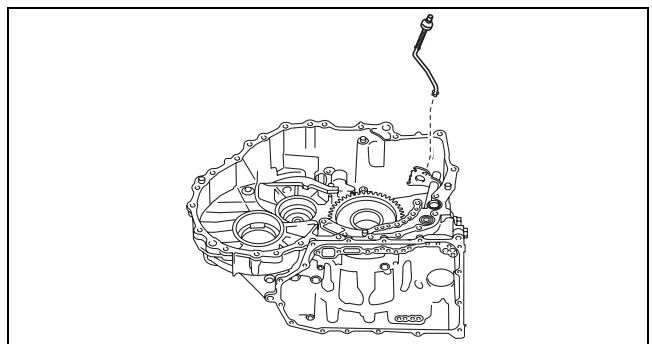

azzjw00000507

AUTOMATIC TRANSAXLE

55. Remove the parking pawl shaft in the order shown in the figure.

1	Plug
2	Gasket
3	Parking pawl shaft

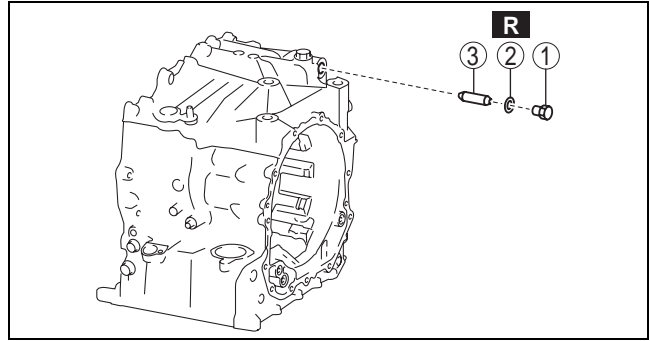

azzjw00000508

56. Remove the parking pawl.

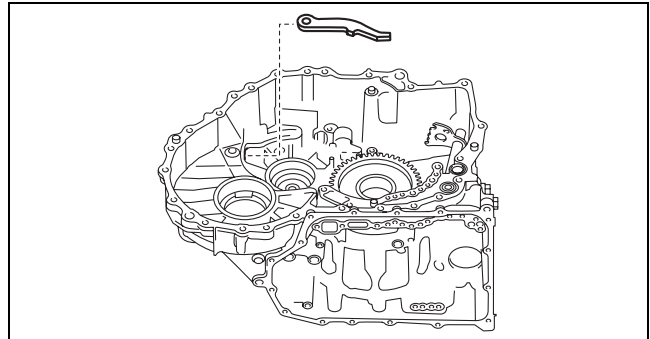

azzjw00000509

57. Remove the roll pins shown in the figure using a pin punch.

Note

- Use a pin punch with an end outer diameter of 3 mm {0.119 in} or more, and within 4 mm {0.157 in}.

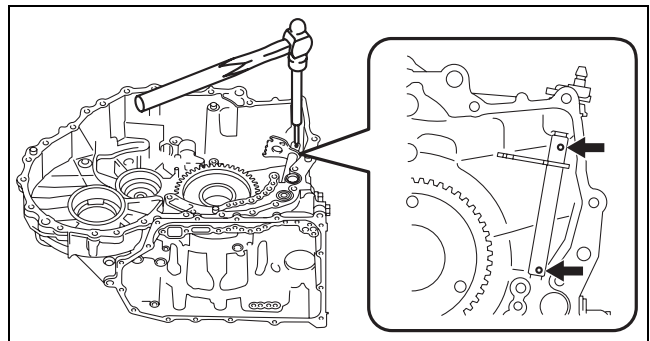

azzjw00000510

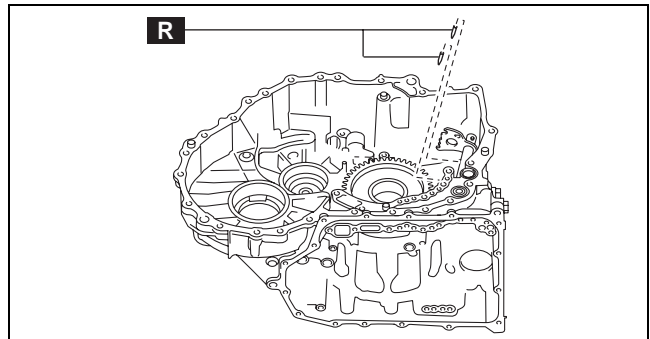

azzjw00001498

AUTOMATIC TRANSAXLE

58. Remove the parking shift lever component.

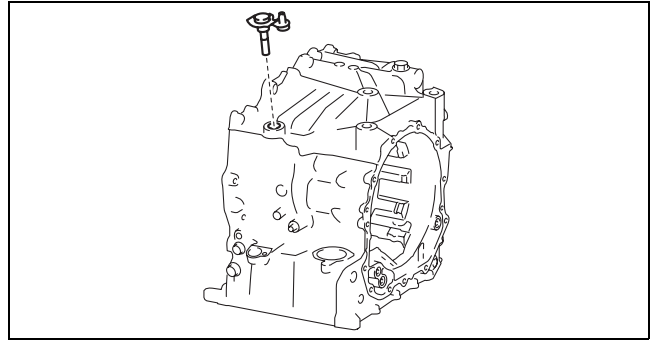

azzjw00000512

59. Remove the parking assist lever component.

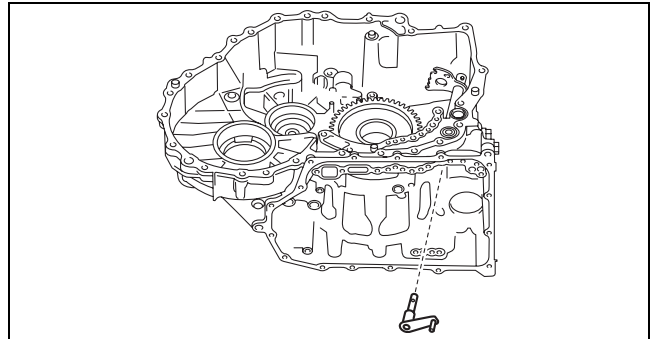

azzjw00000513

60. Remove the manual plate component.

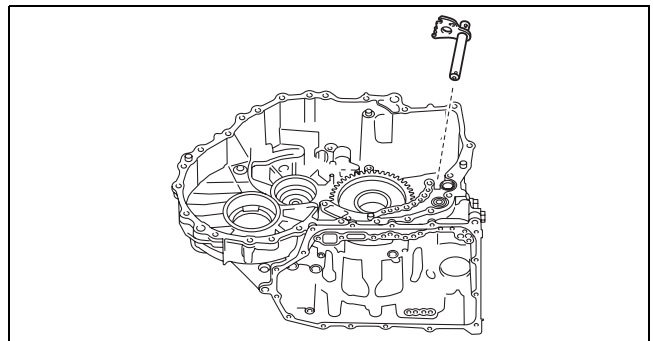

azzjw00000514

61. Remove the oil seal.

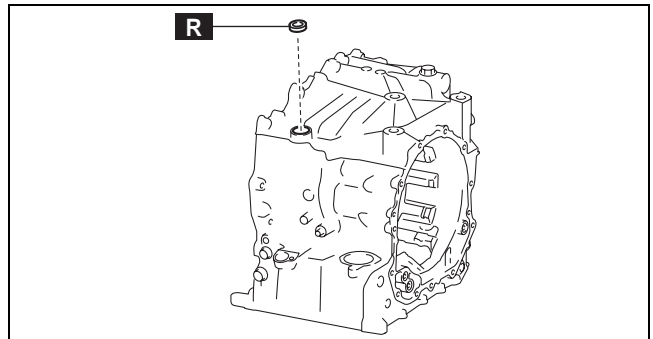

azzjw00000515

AUTOMATIC TRANSAXLE

62. Remove the washer.

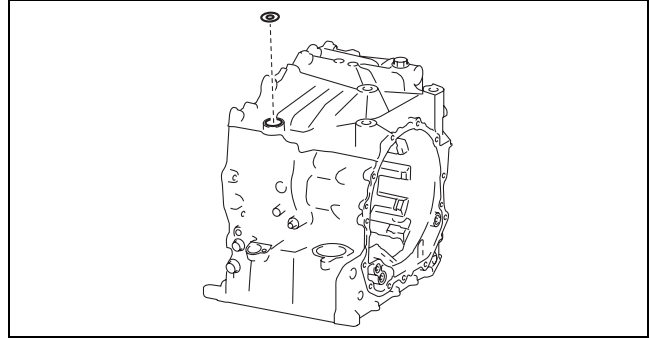

azzjjw00000516

05-17

63. Perform the following procedure only if there is a malfunction found in the Step 40 inspection.

(1) Remove the primary gear using the following procedure:

Caution

- Because the angular contact ball bearing will be damaged if the primary gear is removed, remove the primary gear only if there is a malfunction found in the Step 40 inspection.
- Because the angular contact ball bearing is integrated with the transaxle case, if the primary gear is removed, replace the transaxle case with a new one as when performing the automatic transaxle assembly.

1) When removing the primary gear using the SST, place a rag as an impact-absorbing material on the oil catch area of the SST (engine stand) because the primary gear will drop when removed.

A : Impact-absorbing material (rag)

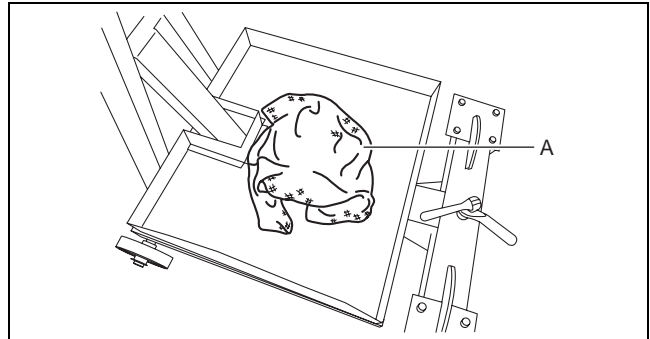

azzjjw00000465

2) Remove the primary gear using the SSTs.

Note

- Use a plastic hammer.

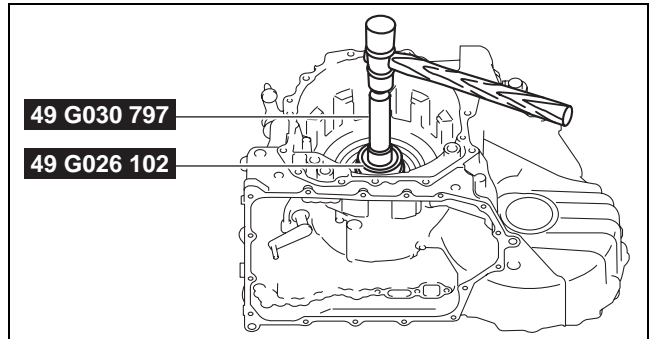

azzjjw00000517

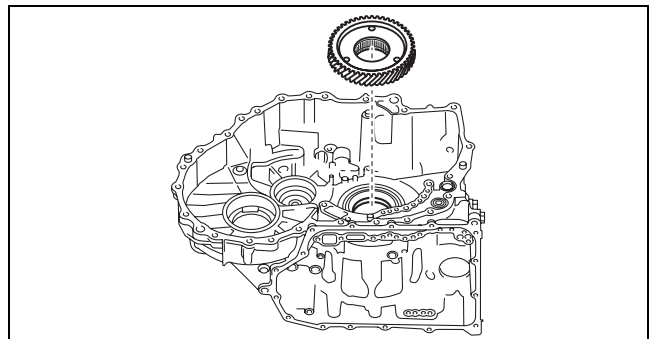

azzjjw00000518

3) Remove the rag placed on the oil catch area of the SST (engine stand) used as an impact-absorbing material.

AUTOMATIC TRANSAXLE

(2) Remove the angular contact ball bearing from the primary gear using the following procedure:

Note

- When removing the primary gear, if the angular contact ball bearing remains in the transaxle case and only the primary gear is removed, the following angular contact ball bearing removal procedure is not necessary.

- 1) Pry the angular contact ball bearing evenly using two flathead screwdrivers to create a gap between the primary gear end and the angular contact ball bearing end until the tab of the SST (49 0839 425C) is inserted.

A : Gap

Note

- If there is already a gap between the primary gear end and the angular contact ball bearing end in which the tab of the SST (49 0839 425C) is inserted when removing the primary gear, this procedure is not necessary.

- 2) Secure the primary gear in a vise.

A : Vise

Caution

- Insert a protective plate between the vise and the part so as not to damage the part.

- 3) Remove the angular contact ball bearing using the SSTs.

A : Vise

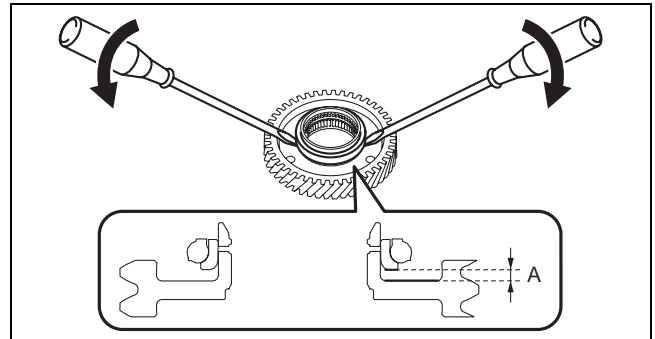

azzjiw00001205

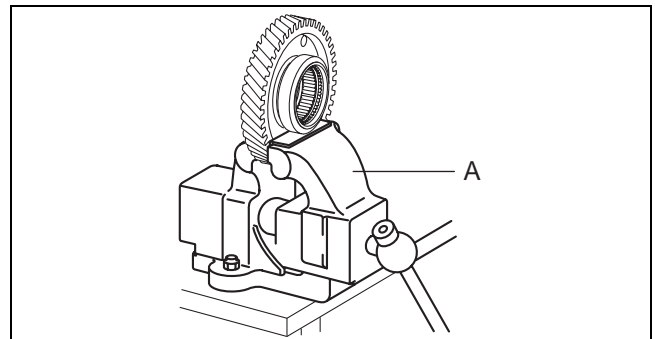

azzjiw00001206

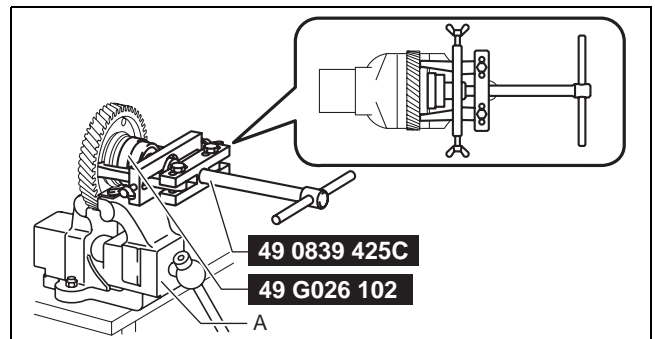

azzjiw00001207

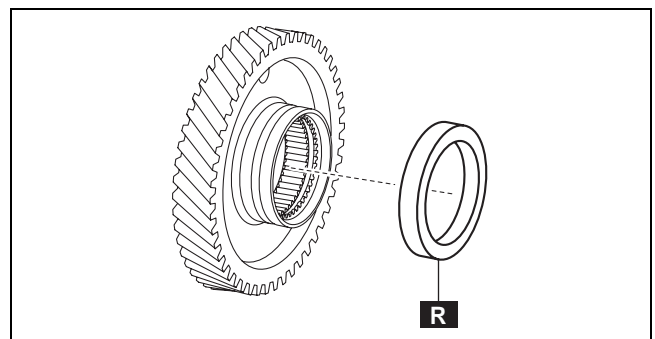

azzjiw00000520

AUTOMATIC TRANSAXLE

4) Remove the primary gear from the vise.

A : Vise

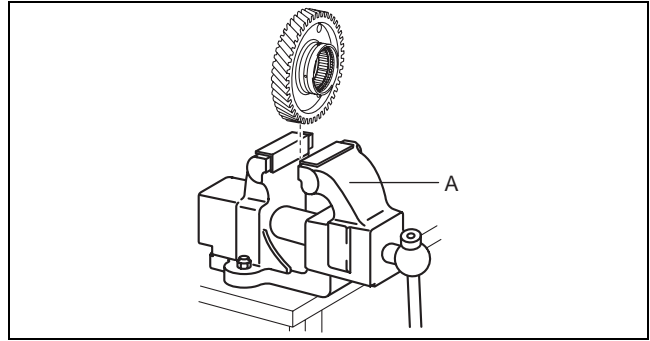

azzjjw00001208

05-17

(3) Remove the plug and gasket in the order shown in the figure.

1	Plug
2	Gasket

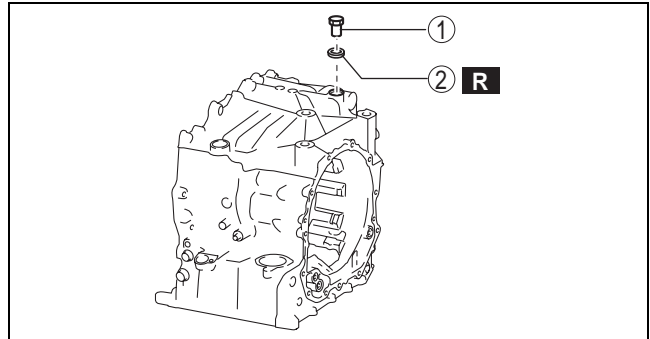

azzjjw00000917

64. Remove the SST from the transaxle case using the following procedure:

(1) Remove the transaxle case from the SST (engine stand).

Caution

- For safety purposes, perform the procedure using two people, one removes the transaxle case from the SST and the other supports the transaxle case.

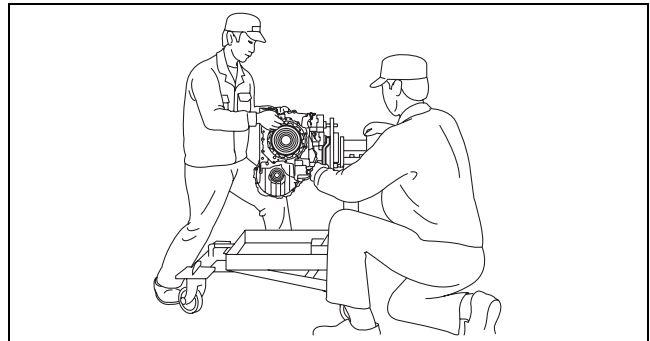

azzjjw00000521

A : Part number: 9YA02 A220, or M12×1.75 bolt, length to 40 mm {1.6 in}

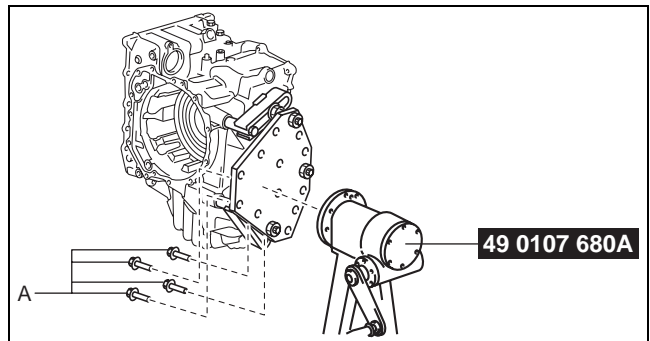

azzjjw00000522

AUTOMATIC TRANSAXLE

(2) Remove the SST from the transaxle case.

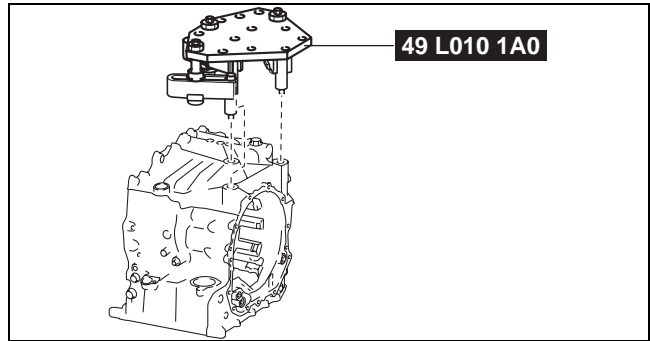

azzjw00000523

(3) Disassemble the SST.

A : Part number: 9YA02 1440, or M14×1.5 bolt,
length to 100 mm {3.94 in}

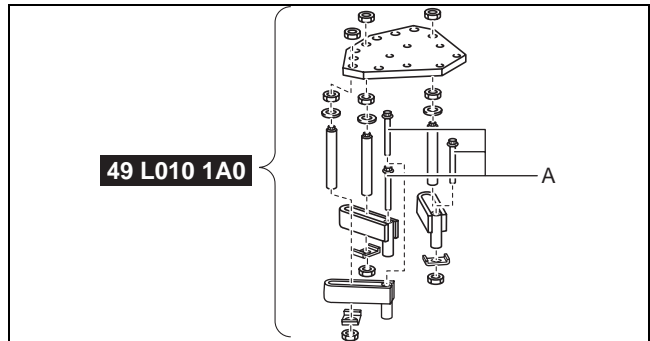

azzjw00000524

65. Disassemble the parts in the following order.

Note

- Disassemble the parts in the following order because the parts in the transaxle may be used for inspection, measurement, or adjustment.

- (1) Clutch component (See 05-17-104 CLUTCH COMPONENT DISASSEMBLY)
- (2) Oil pump (See 05-17-115 OIL PUMP DISASSEMBLY)
- (3) Rear planetary gear (See 05-17-117 REAR PLANETARY GEAR DISASSEMBLY)
- (4) Secondary gear and output gear (See 05-17-119 SECONDARY GEAR AND OUTPUT GEAR DISASSEMBLY)
- (5) Ring gear and differential (See 05-17-121 RING GEAR AND DIFFERENTIAL DISASSEMBLY)
- (6) End cover component (See 05-17-128 END COVER COMPONENT DISASSEMBLY)
- (7) Reduction planetary gear (See 05-17-136 REDUCTION PLANETARY GEAR DISASSEMBLY)
- (8) Control valve body (See 05-17-138 CONTROL VALVE BODY DISASSEMBLY)

66. Clean away the remaining silicone sealant on the transaxle case, converter housing, end cover, and the oil pan.

67. Clean the disassembled parts. (See 05-17-26 AUTOMATIC TRANSAXLE CLEANING.)

AUTOMATIC TRANSAXLE

68. Perform the following inspection and replace a malfunctioning part with a new one.
- Visual inspection of parts (See 05-17-151 VISUAL INSPECTION OF PARTS)
 - Torque converter inspection (See 05-17-154 TORQUE CONVERTER INSPECTION)
 - Thrust needle bearing inspection (See 05-17-155 THRUST NEEDLE BEARING INSPECTION)
 - Front planetary gear inspection (See 05-17-155 FRONT PLANETARY GEAR INSPECTION)
 - Rear planetary gear inspection (See 05-17-158 REAR PLANETARY GEAR INSPECTION)
 - Reduction planetary gear inspection (See 05-17-161 REDUCTION PLANETARY GEAR INSPECTION)
 - Secondary gear and output gear inspection (See 05-17-163 SECONDARY GEAR AND OUTPUT GEAR INSPECTION)
 - Ring gear and differential inspection (See 05-17-165 RING GEAR AND DIFFERENTIAL INSPECTION)
 - Low clutch inspection (See 05-17-169 LOW CLUTCH INSPECTION)
 - High clutch inspection (See 05-17-169 HIGH CLUTCH INSPECTION)
 - Low and reverse brake inspection (See 05-17-170 LOW AND REVERSE BRAKE INSPECTION)
 - 2-6 brake inspection (See 05-17-171 2-6 BRAKE INSPECTION)
 - R-3-5 brake inspection (See 05-17-171 R-3-5 BRAKE INSPECTION)
 - One-way clutch inspection (See 05-17-172 ONE-WAY CLUTCH INSPECTION)
 - Low clutch hub inspection (See 05-17-173 LOW CLUTCH HUB INSPECTION)
 - High clutch hub inspection (See 05-17-173 HIGH CLUTCH HUB INSPECTION)
 - Oil pump inspection (See 05-17-174 OIL PUMP INSPECTION)
 - End cover inspection (See 05-17-177 END COVER INSPECTION)
 - Oil cooler inspection (See 05-17-177 OIL COOLER INSPECTION)

05-17

AUTOMATIC TRANSAXLE

CLUTCH COMPONENT DISASSEMBLY

id051700660700

Structural View

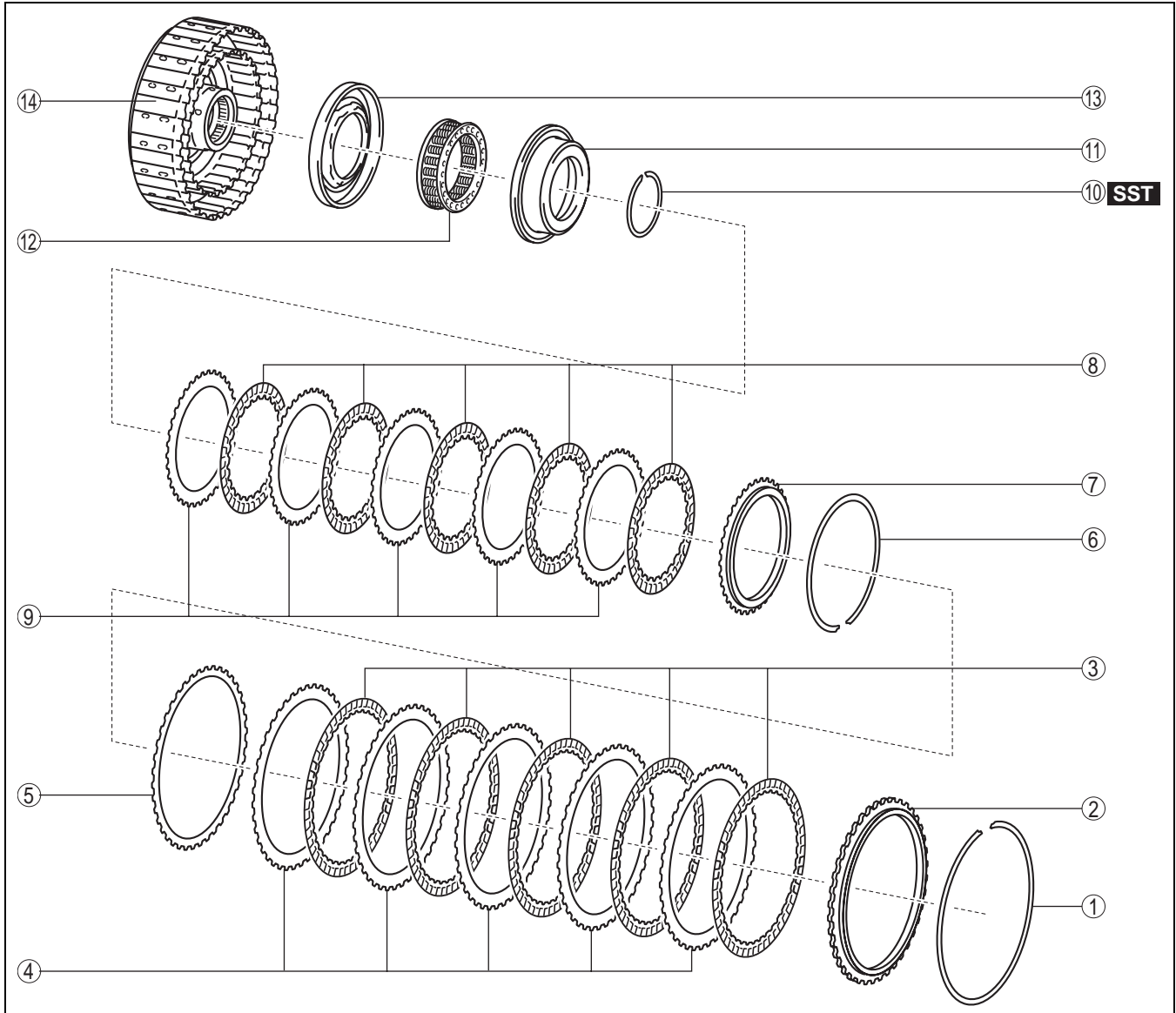

azzjw00001430

1	Snap ring
2	Retaining plate
3	Drive plate
4	Driven plate
5	Wave spring
6	Snap ring
7	Retaining plate

8	Drive plate
9	Driven plate
10	Snap ring
11	Seal plate
12	Springs and retainer component
13	High clutch piston
14	High clutch drum component

AUTOMATIC TRANSAXLE

Disassembly Procedure

1. Perform a simple inspection of the low clutch and high clutch using the following procedure:

- (1) Set the oil pump on the workbench as shown in the figure.

A : Rubber plate

Note

- Using the rubber plates, adjust the alignment surface of the oil pump with the transaxle case so that it is level.

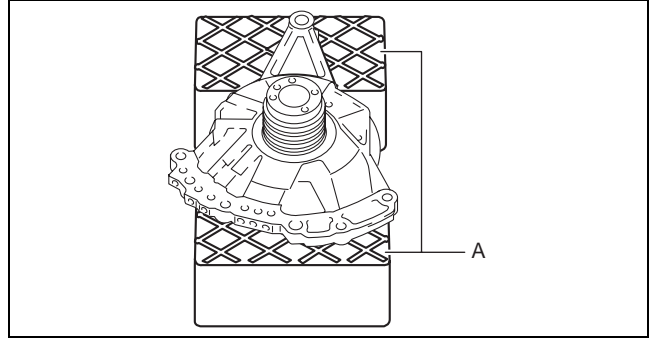

azzjjw00000802

05-17

(2) Assemble the thrust needle bearing to the clutch component using the following procedure:

Note

- Thrust needle bearing size: Outer diameter approx. 72.7 mm {2.86 in}
- 1) To prevent the thrust needle bearing from dropping out, apply ATF (ATF FZ) to the thrust needle bearing.
 - 2) Assemble the thrust needle bearing.

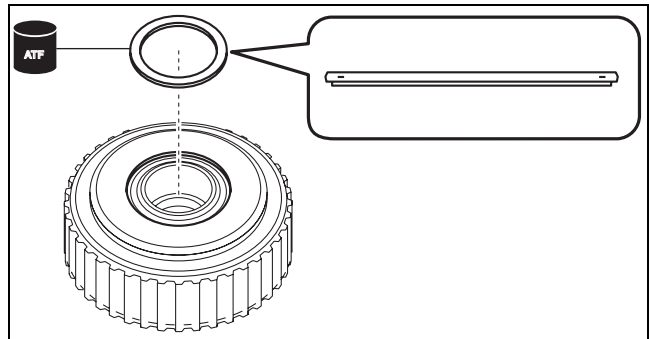

azzjjw00000803

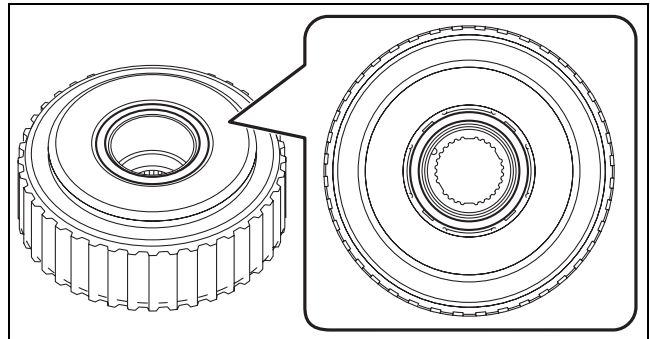

azzjjw00000804

AUTOMATIC TRANSAXLE

- (3) Assemble the parts assembled together in Step (2) to the oil pump.

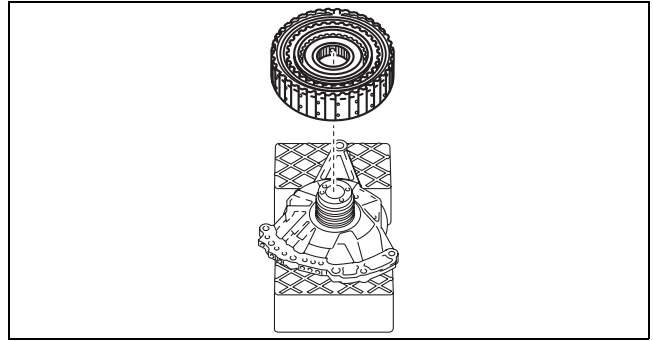

azzjw00000805

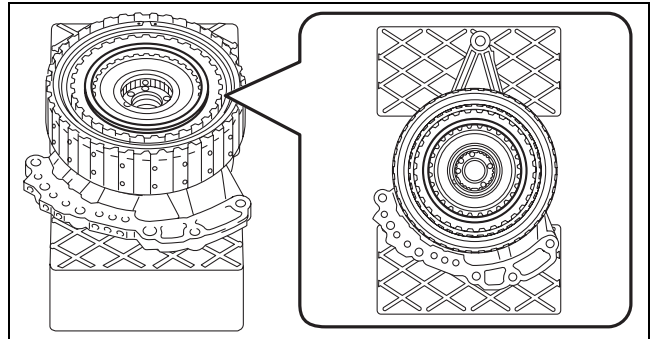

azzjw00000806

- (4) Blow compressed air into the oil passage shown in the figure and verify the operation condition of the low clutch.

Warning

- Always wear protective eye wear when using the air compressor. Otherwise, ATF or dirt particles blown off by the air compressor could get into the eyes.

Caution

- To prevent damage to parts, always use an air compressor which is adjusted to the indicated pressure.

Compressed air pressure

0.39—0.44 MPa {4.0—4.4 kgf/cm², 57—63 psi}

- If there is a malfunction, verify the cause and repair the applicable part after disassembly.

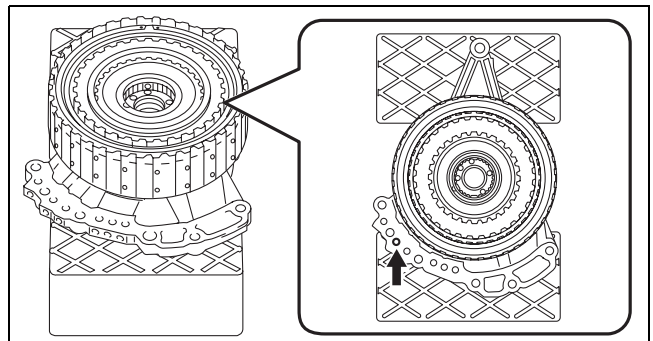

azzjw00000807

AUTOMATIC TRANSAXLE

- (5) Blow compressed air into the oil passage shown in the figure and verify the operation condition of the high clutch.

Warning

- Always wear protective eye wear when using the air compressor. Otherwise, ATF or dirt particles blown off by the air compressor could get into the eyes.

Caution

- To prevent damage to parts, always use an air compressor which is adjusted to the indicated pressure.

Compressed air pressure

0.39—0.44 MPa {4.0—4.4 kgf/cm², 57—63 psi}

- If there is a malfunction, verify the cause and repair the applicable part after disassembly.

- (6) Remove the clutch component.

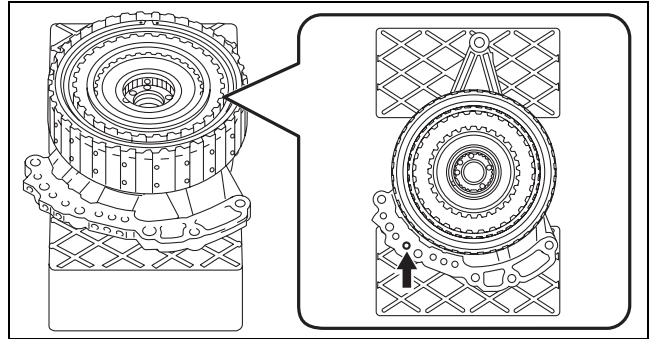

azzjw00000808

05-17

- (6) Remove the clutch component.

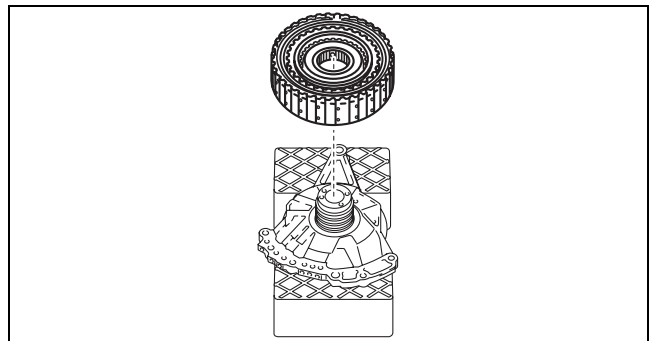

azzjw00000809

- (7) Remove the thrust needle bearing.

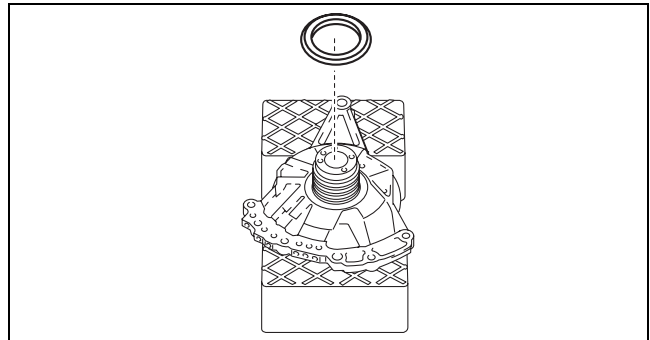

azzjw00000810

- (8) Take the oil pump off the rubber plates.

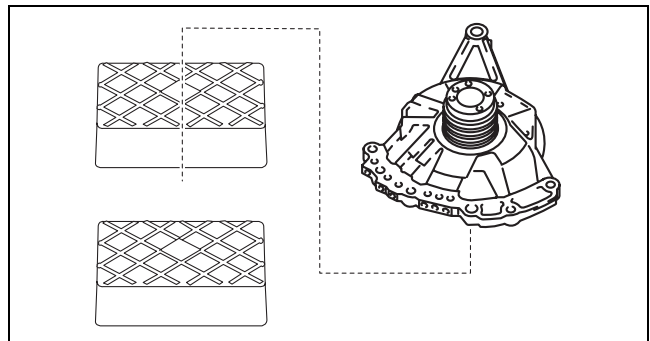

azzjw00001202

AUTOMATIC TRANSAXLE

2. Remove the snap ring.

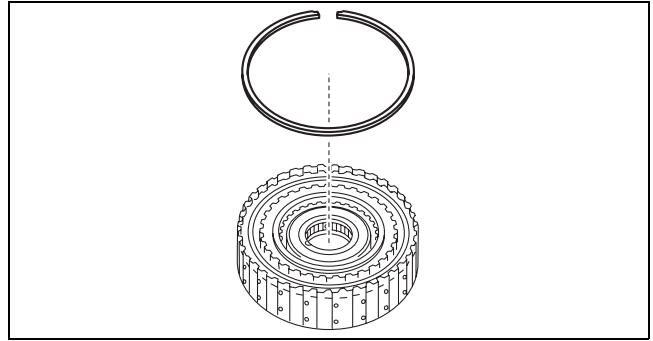

azzjw00000812

3. Remove the retaining plate.

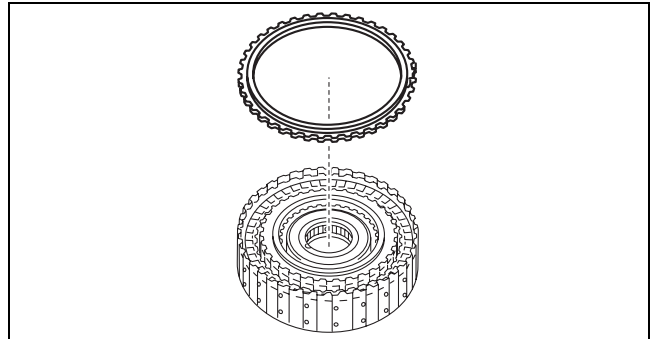

azzjw00000813

4. Remove the drive plates and driven plates.

A : Drive plate
B : Driven plate

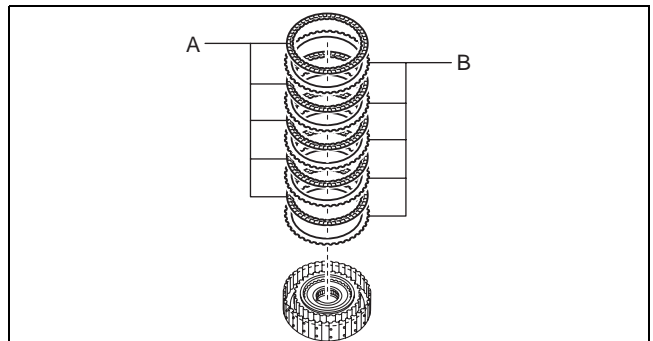

azzjw00000814

5. Remove the wave spring.

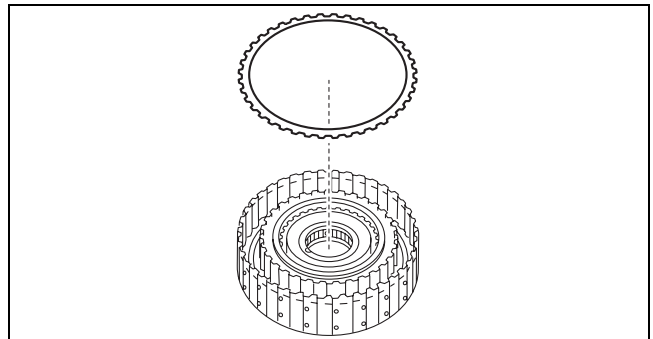

azzjw00000815

AUTOMATIC TRANSAXLE

6. Remove the snap ring.

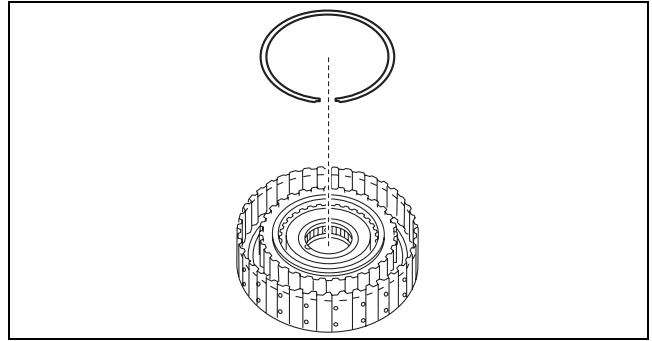

azzjw00000816

7. Remove the retaining plate.

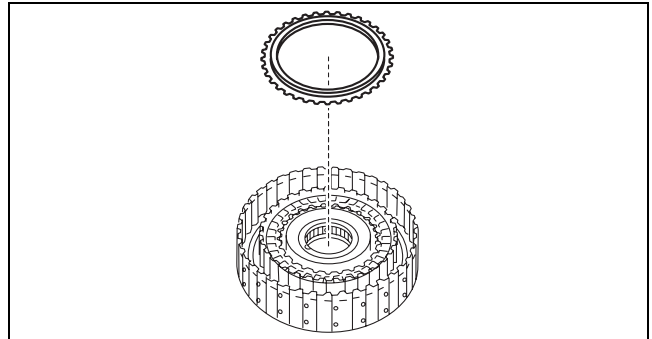

azzjw00000817

8. Remove the drive plates and driven plates.
A : Drive plate
B : Driven plate

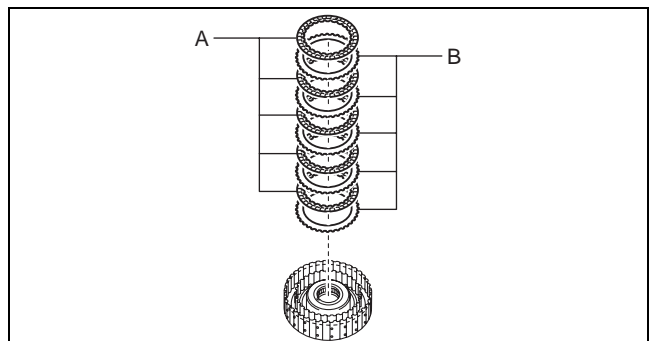

azzjw00000818

05-17

AUTOMATIC TRANSAXLE

9. Remove the snap ring using the following procedure:
 (1) Install the SSTs.

- A : Nut included with SST (49 G019 025), or M8×1.25 nut
- B : Washer

Note

- When installing the SST (49 G019 025) to the SST (49 G019 026), use the nuts included with the SST (49 G019 025), or M8×1.25 nuts.

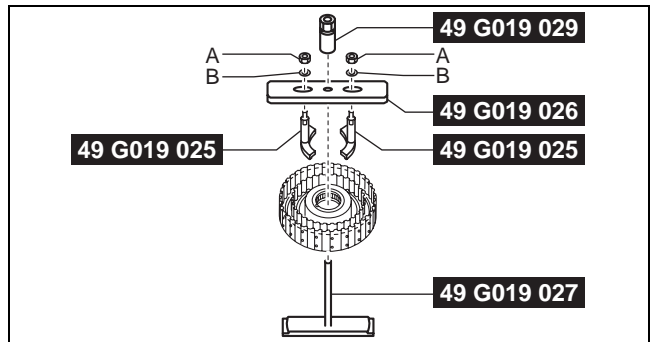

azzjiw00000819

- A : Nut included with SST (49 G019 025), or M8×1.25 nut
- B : Washer

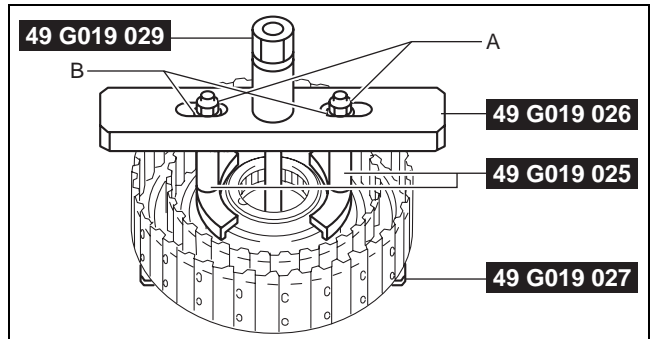

azzjiw00000820

(2) Tighten the SST (49 G019 029) until there is no longer any spring force from the springs and retainer component applied to the snap ring.

- A : Snap ring
- B : Seal plate
- C : Gap

Caution

- If the SST (49 G019 029) is tightened with excessive force, surrounding parts could be damaged. Stop tightening if a gap appears between the snap ring and seal plate.

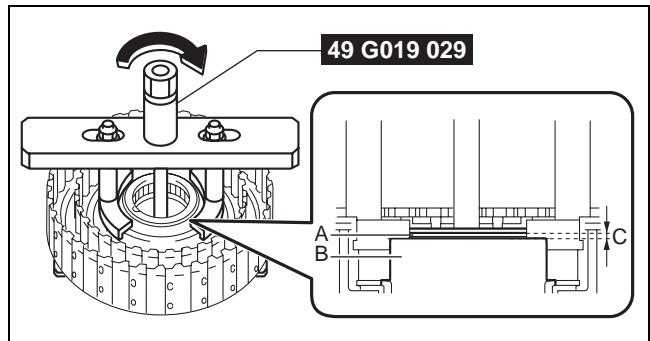

azzjiw00000821

(3) Remove the snap ring from the snap ring groove.

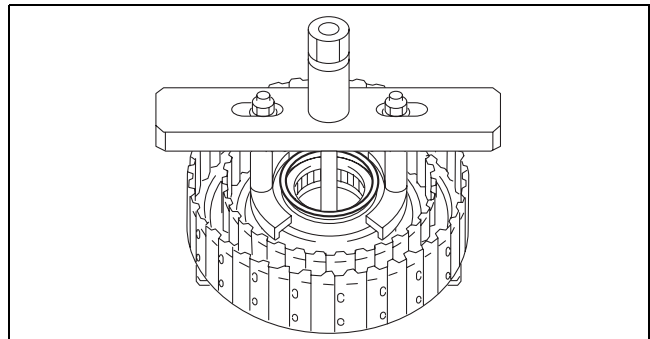

azzjiw00000822

AUTOMATIC TRANSAXLE

- (4) Loosen the SST (49 G019 029) and remove the SSTs.

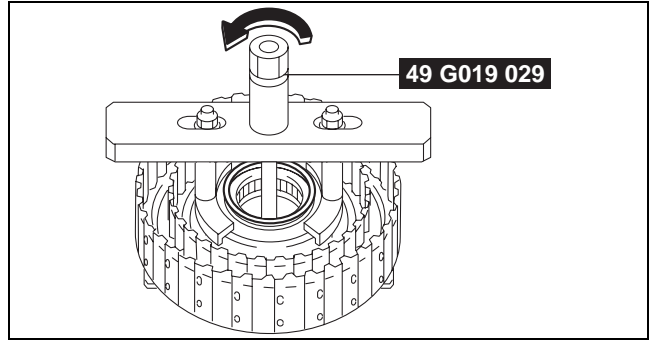

azzjjw00000823

- A : Nut included with SST (49 G019 025), or
M8×1.25 nut
B : Washer

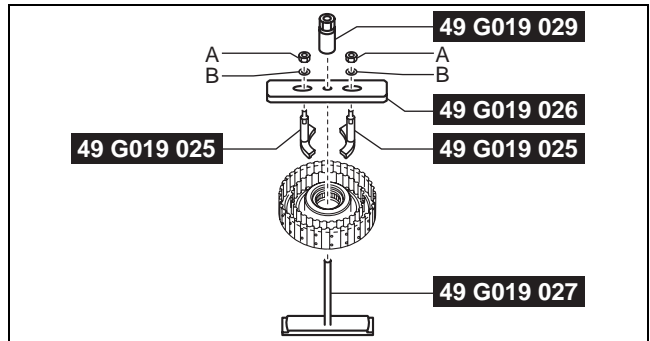

azzjjw00000824

- (5) Remove the snap ring removed from the snap ring groove.

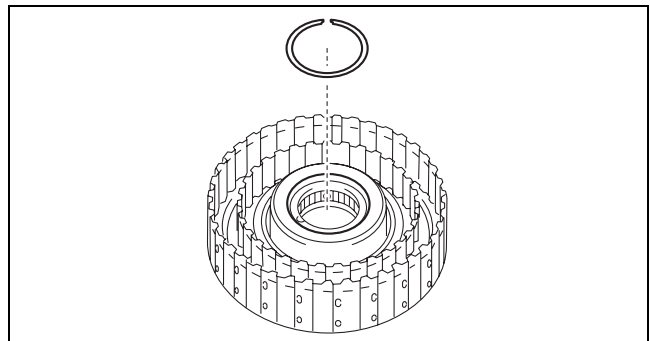

azzjjw00000825

10. Remove the seal plate.

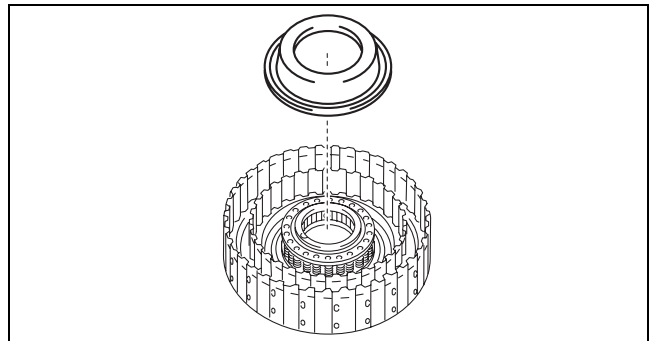

azzjjw00000826

05-17

AUTOMATIC TRANSAXLE

11. Remove the springs and retainer component.

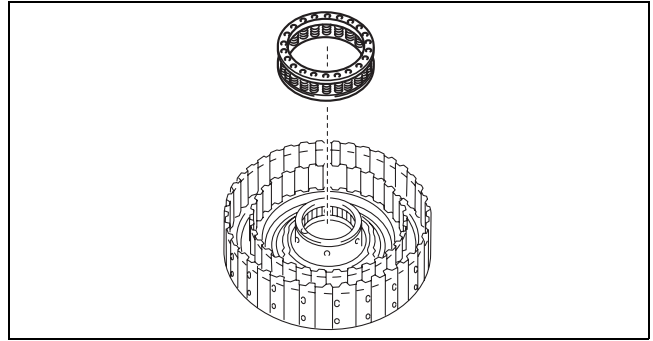

azzjw00000827

12. Remove the high clutch piston using the following procedure:

(1) Set the oil pump on the workbench as shown in the figure.

A : Rubber plate

Note

- Using the rubber plates, adjust the alignment surface of the oil pump with the transaxle case so that it is level.

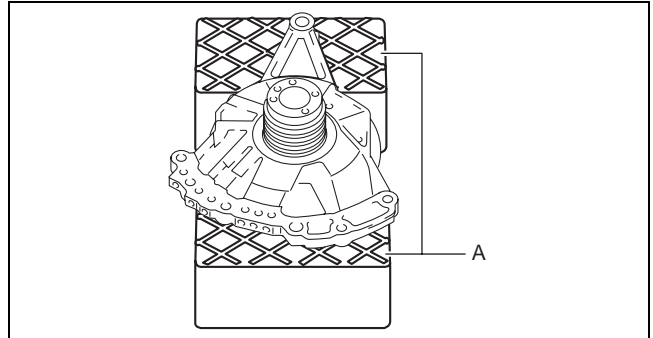

azzjw00000802

(2) Assemble the thrust needle bearing to the high clutch drum component using the following procedure:

Note

- Thrust needle bearing size: Outer diameter approx. 72.7 mm {2.86 in}
- 1) To prevent the thrust needle bearing from dropping out, apply ATF (ATF FZ) to the thrust needle bearing.
 - 2) Assemble the thrust needle bearing.

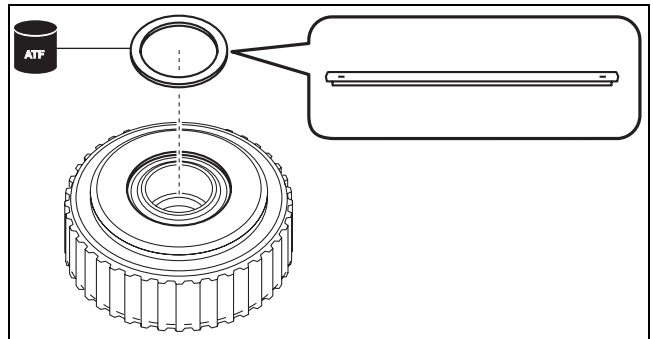

azzjw00000803

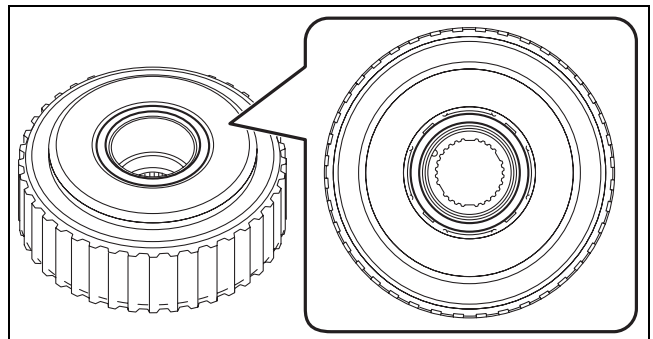

azzjw00000804

AUTOMATIC TRANSAXLE

- (3) Assemble the parts assembled together in Step (2) to the oil pump.

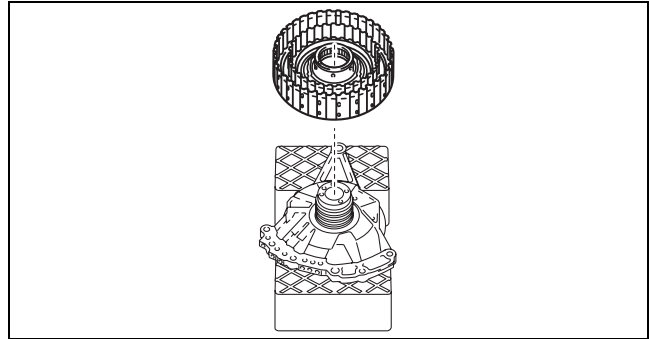

azzjw00000828

05-17

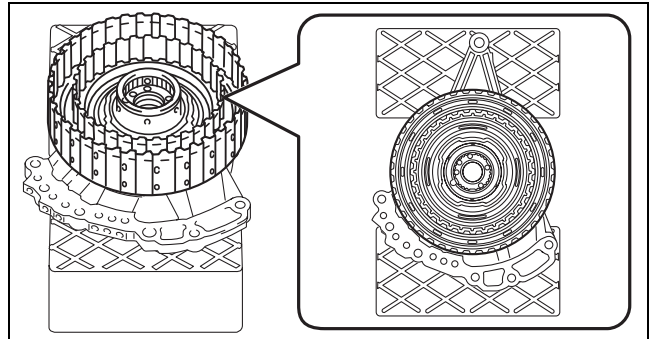

azzjw00000829

- (4) Blow compressed air into the oil passage shown in the figure.

Warning

- Always wear protective eye wear when using the air compressor. Otherwise, ATF or dirt particles blown off by the air compressor could get into the eyes.

Caution

- To prevent damage to parts, always use an air compressor which is adjusted to the indicated pressure.

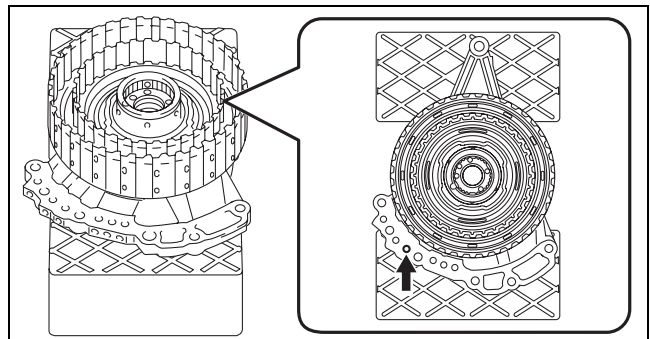

azzjw00000830

Compressed air pressure

0.39—0.44 MPa {4.0—4.4 kgf/cm², 57—63 psi}

- (5) Remove the high clutch piston removed from the high clutch drum component.

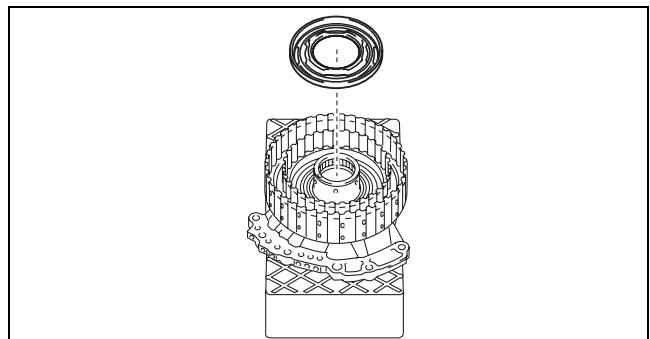

azzjw00000831

AUTOMATIC TRANSAXLE

(6) Remove the high clutch drum component.

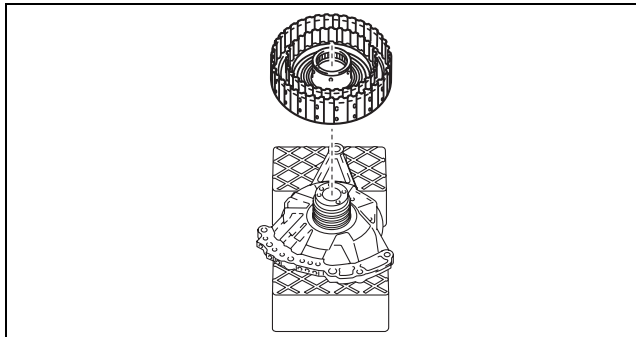

azzjiw00000832

(7) Remove the thrust needle bearing.

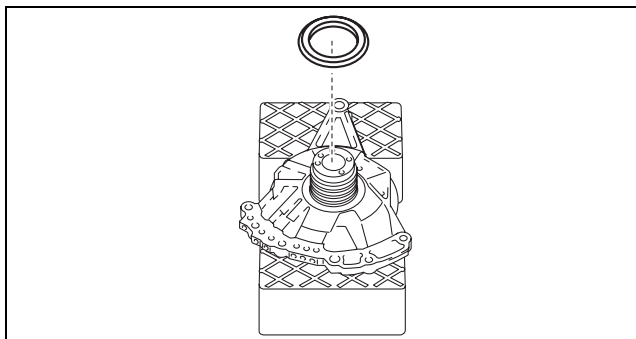

azzjiw00000810

(8) Take the oil pump off the rubber plates.

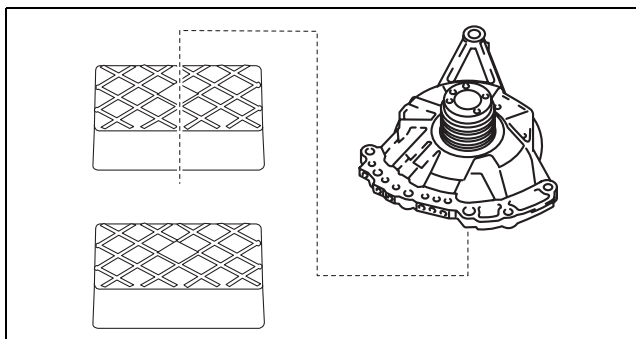

azzjiw00001202

13. Clean the disassembled parts. (See 05-17-26 AUTOMATIC TRANSAXLE CLEANING.)

14. Perform the following inspection and replace a malfunctioning part with a new one.

- Visual inspection of parts (See 05-17-151 VISUAL INSPECTION OF PARTS)
- Low clutch inspection (See 05-17-169 LOW CLUTCH INSPECTION)
- High clutch inspection (See 05-17-169 HIGH CLUTCH INSPECTION)

AUTOMATIC TRANSAXLE

OIL PUMP DISASSEMBLY

id051700660800

Structural View

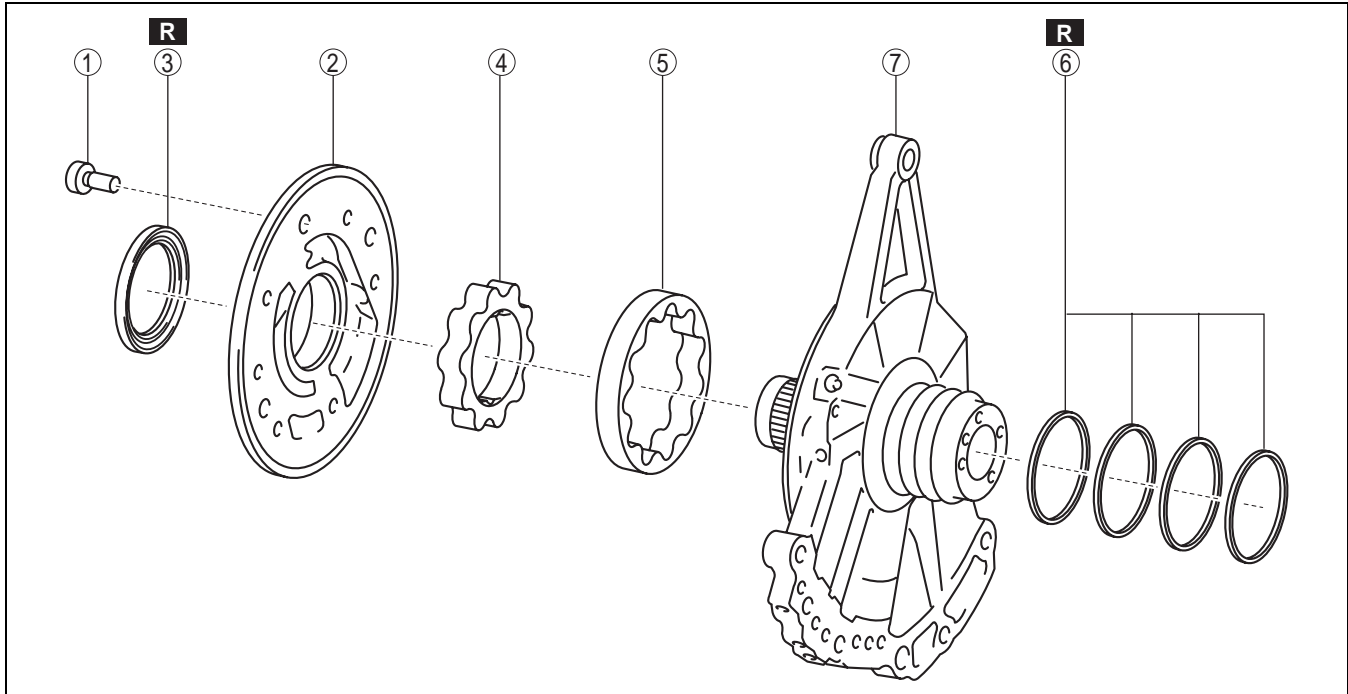

05-17

azzjjw00001431

1	7 bolts
2	Oil pump cover
3	Oil seal
4	Inner rotor

5	Outer rotor
6	Seal ring
7	Oil pump housing

Disassembly Procedure

1. Remove the oil pump cover using the following procedure:

1	7 bolts
2	Oil pump cover

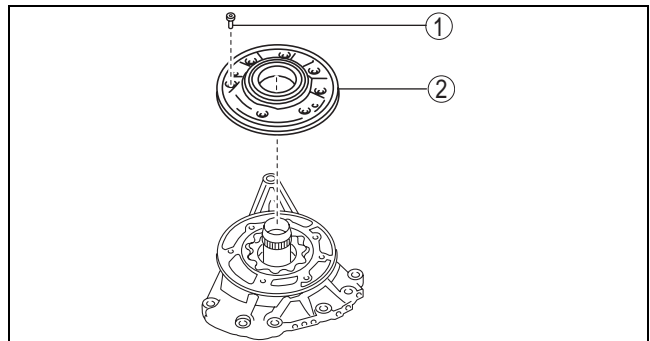

azzjjw00000833

(1) Remove the bolts shown in the figure.

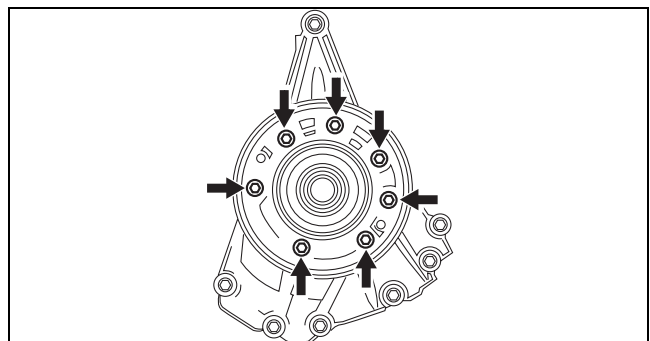

azzjjw00000834

AUTOMATIC TRANSAXLE

(2) Remove the oil pump cover.

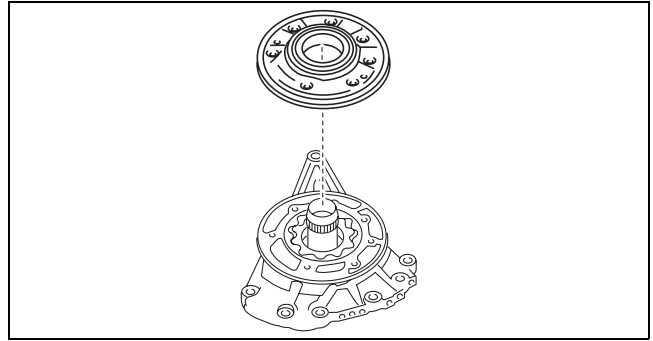

azzjw00000835

2. Remove the oil seal.

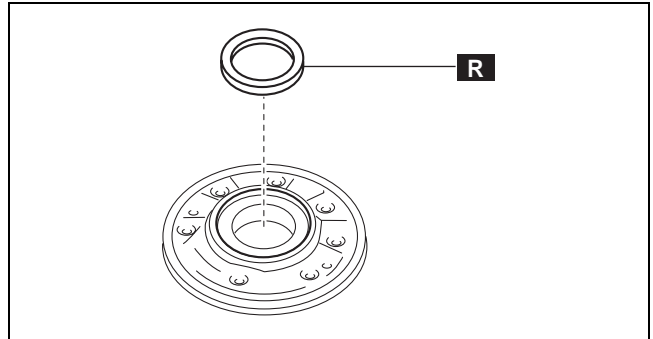

azzjw00000836

3. Remove the inner rotor.

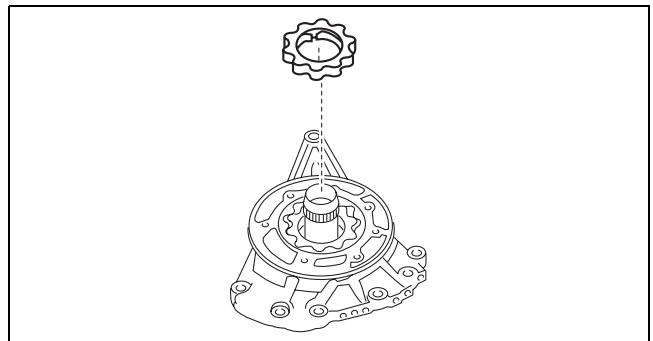

azzjw00000837

4. Remove the outer rotor.

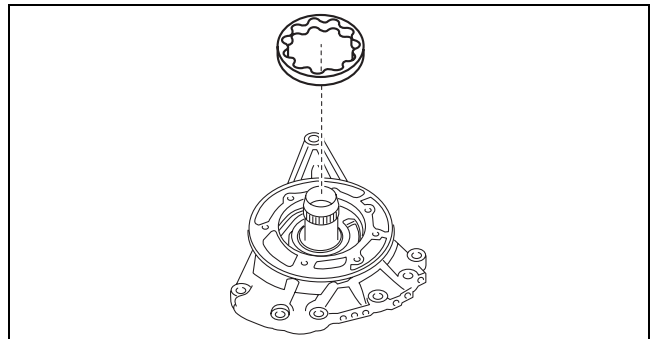

azzjw00000838

AUTOMATIC TRANSAXLE

5. Remove the seal rings.

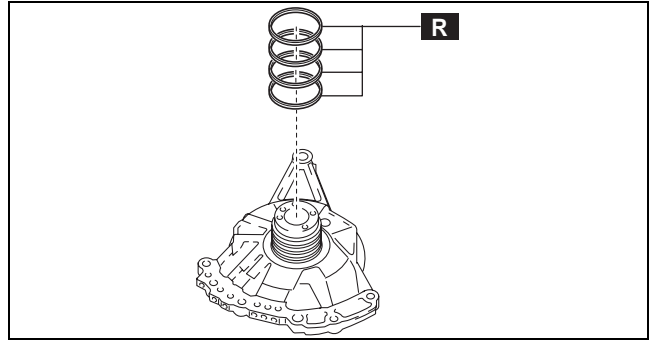

azzjw00000839

05-17

6. Clean the disassembled parts. (See 05-17-26 AUTOMATIC TRANSAXLE CLEANING.)

7. Perform the following inspection and replace a malfunctioning part with a new one.

- Visual inspection of parts (See 05-17-151 VISUAL INSPECTION OF PARTS)
- Oil pump inspection (See 05-17-174 OIL PUMP INSPECTION)

REAR PLANETARY GEAR DISASSEMBLY

id051700660900

Structural View

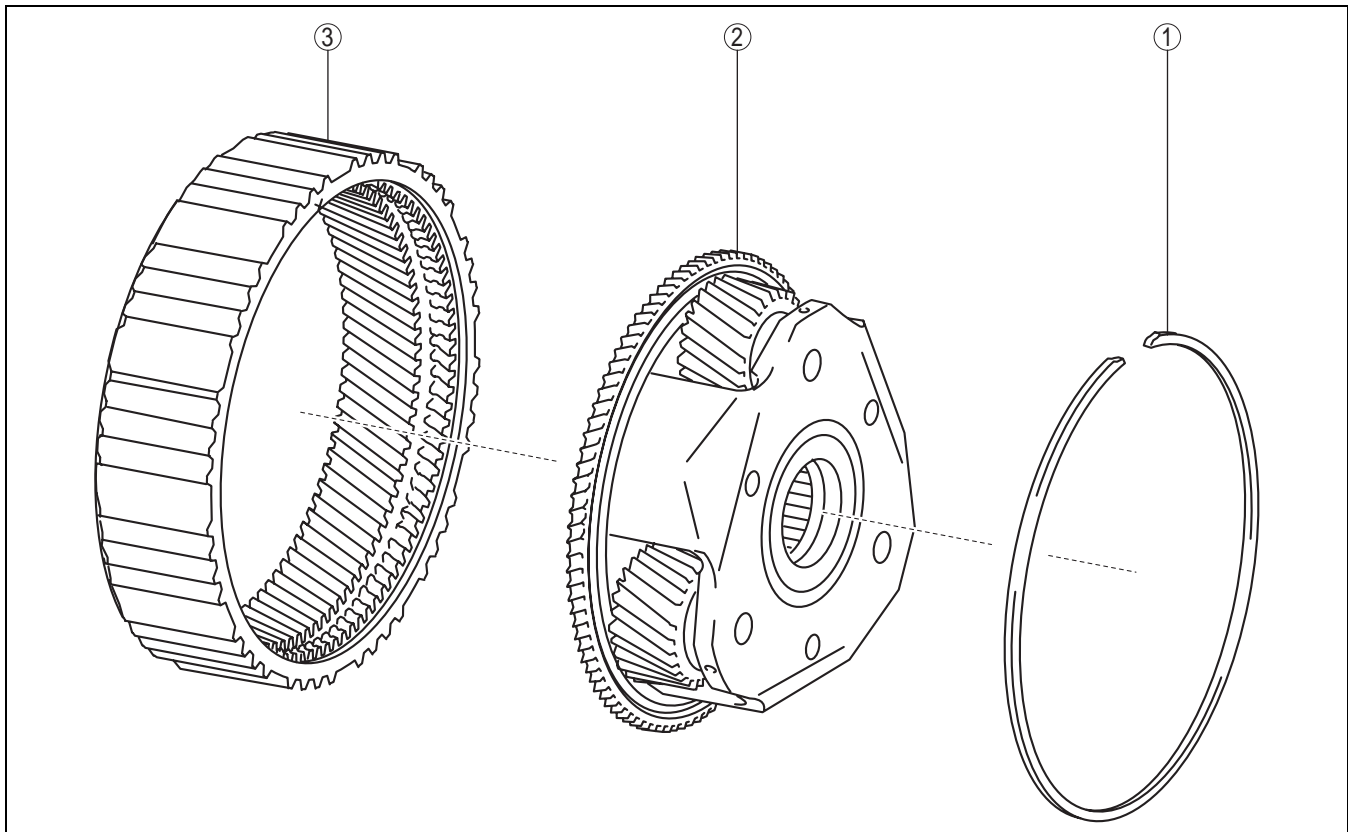

azzjw00001432

1	Snap ring
2	Rear planetary carrier

3	Front internal gear
---	---------------------

AUTOMATIC TRANSAXLE

Disassembly Procedure

1. Perform the following inspection:

Caution

- If there is no malfunction based on the results of the inspection, it is not necessary to disassemble the rear planetary gear.

- Visual inspection of parts (See 05-17-151 VISUAL INSPECTION OF PARTS)
- Rear planetary gear inspection (See 05-17-158 REAR PLANETARY GEAR INSPECTION)

- If there is a malfunction, disassemble the rear planetary gear and replace the malfunctioning part with a new part.

2. Remove the snap ring.

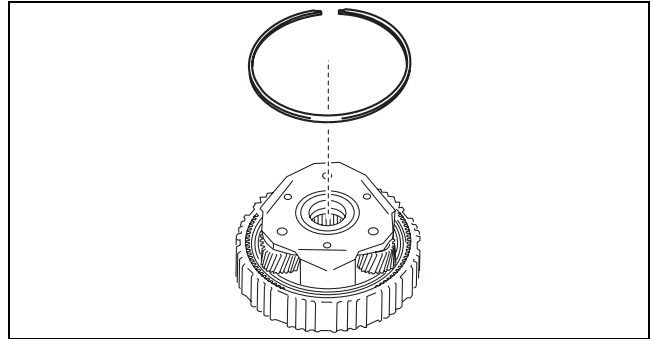

azzjiw00000840

Note

When removing the snap ring, insert a precision flathead screwdriver into the position (between front internal gear and snap ring brim) shown in the figure and the snap ring can be easily removed by prying the snap ring brim.

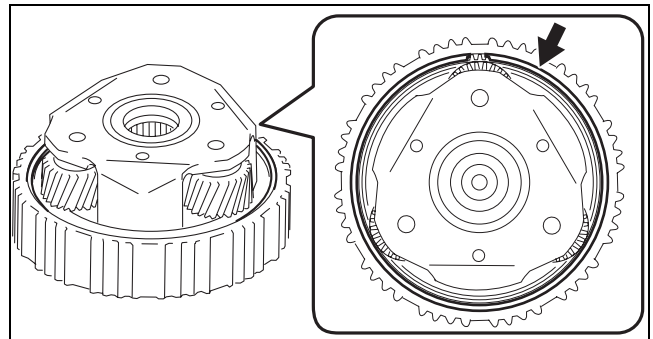

azzjiw00001433

3. Remove the rear planetary carrier.

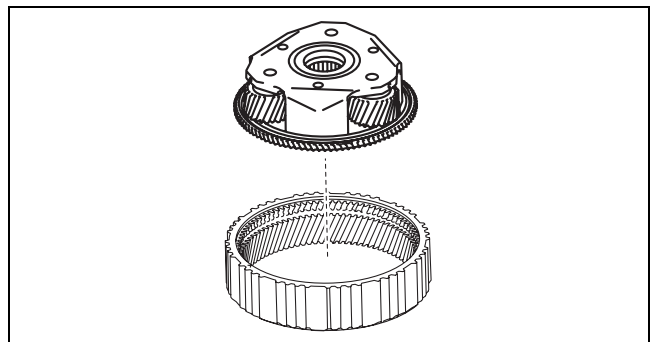

azzjiw00001434

4. Clean the disassembled parts. (See 05-17-26 AUTOMATIC TRANSAXLE CLEANING.)

AUTOMATIC TRANSAXLE

SECONDARY GEAR AND OUTPUT GEAR DISASSEMBLY

id051700661000

Structural View

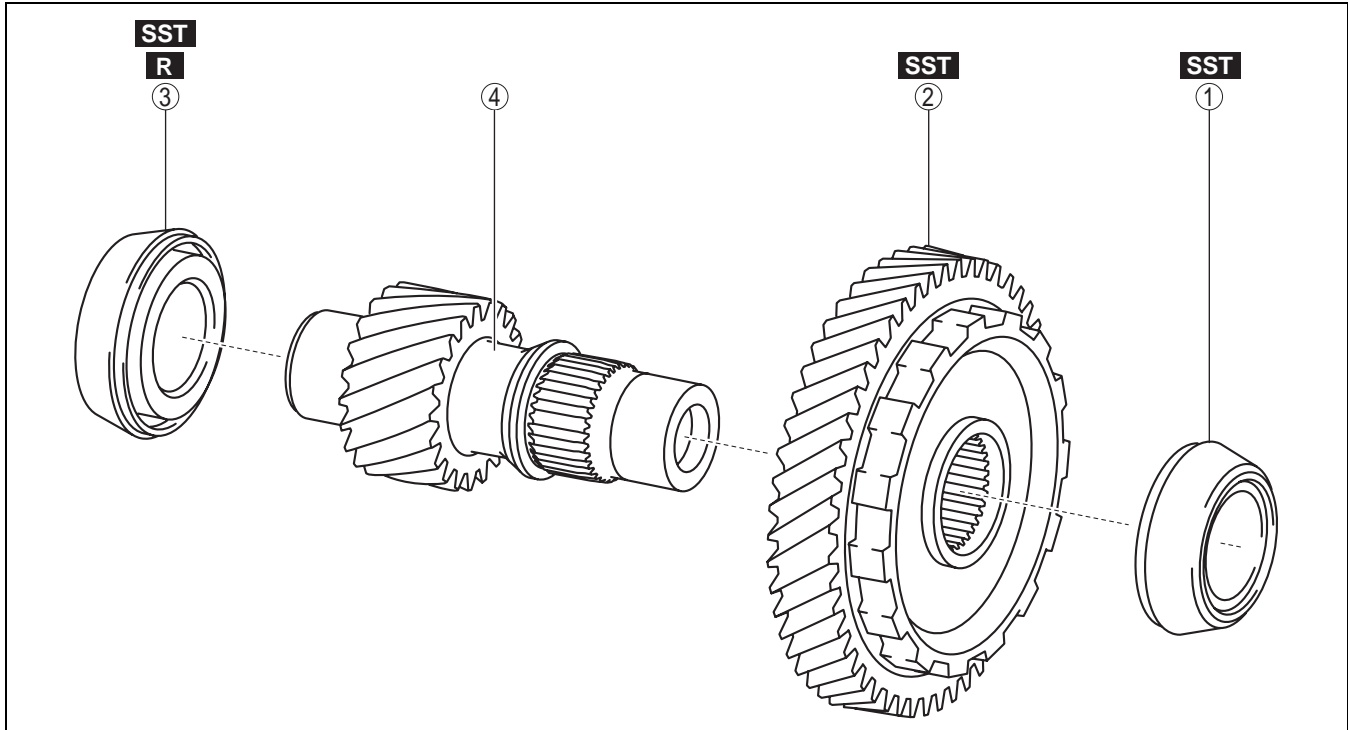

05-17

azzjjw00001469

1	Taper roller bearing (transaxle case side)
2	Secondary gear

3	Taper roller bearing (converter housing side)
4	Output gear

Disassembly Procedure

1. Perform the following inspection:

Caution

- If there is no malfunction based on the results of the inspection, it not necessary to disassemble the secondary gear and output gear.
- Visual inspection of parts (See 05-17-151 VISUAL INSPECTION OF PARTS)
- Secondary gear and output gear inspection (See 05-17-163 SECONDARY GEAR AND OUTPUT GEAR INSPECTION)
- If there is a malfunction, disassemble the secondary gear and output gear and replace the malfunctioning part with a new part.

AUTOMATIC TRANSAXLE

2. Using the SST and press, remove the secondary gear and the taper roller bearing (transaxle case side).

A : Press

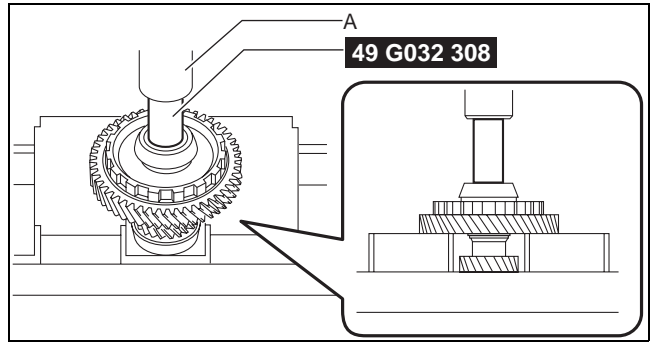

azzjiw00000947

- A : Taper roller bearing (transaxle case side)
B : Secondary gear

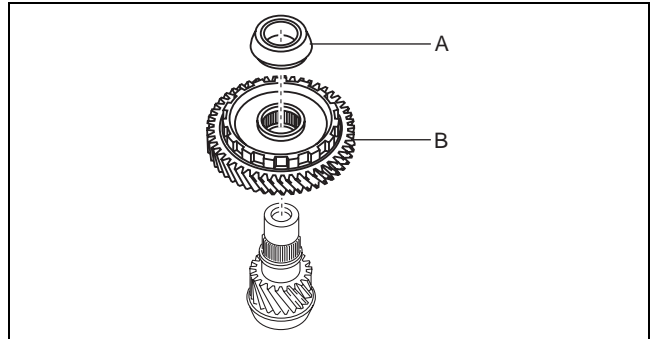

azzjiw00000948

3. Using the SSTs and press, remove the taper roller bearing (converter housing side).

A : Press

Caution

- When removing the taper roller bearing, the cage will deform when the SST is put on the taper roller bearing cage. When assembling the secondary gear and output gear, use a new taper roller bearing.

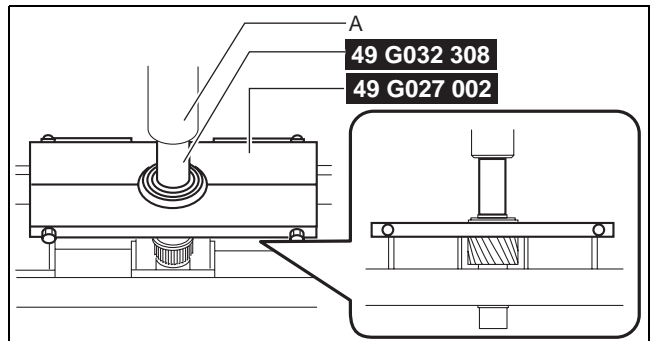

azzjiw00000949

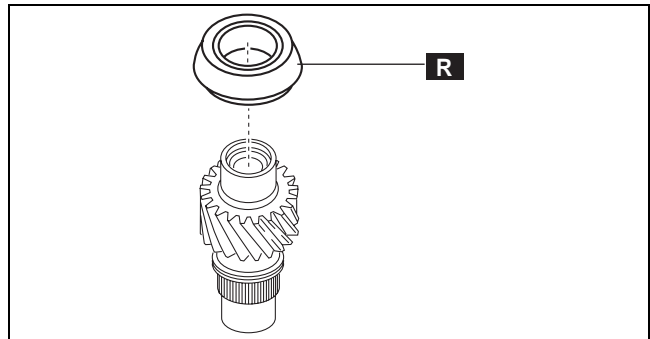

azzjiw00000950

4. Clean the disassembled parts. (See 05-17-26 AUTOMATIC TRANSAXLE CLEANING.)

AUTOMATIC TRANSAXLE

RING GEAR AND DIFFERENTIAL DISASSEMBLY

id051700661100

Structural View

05-17

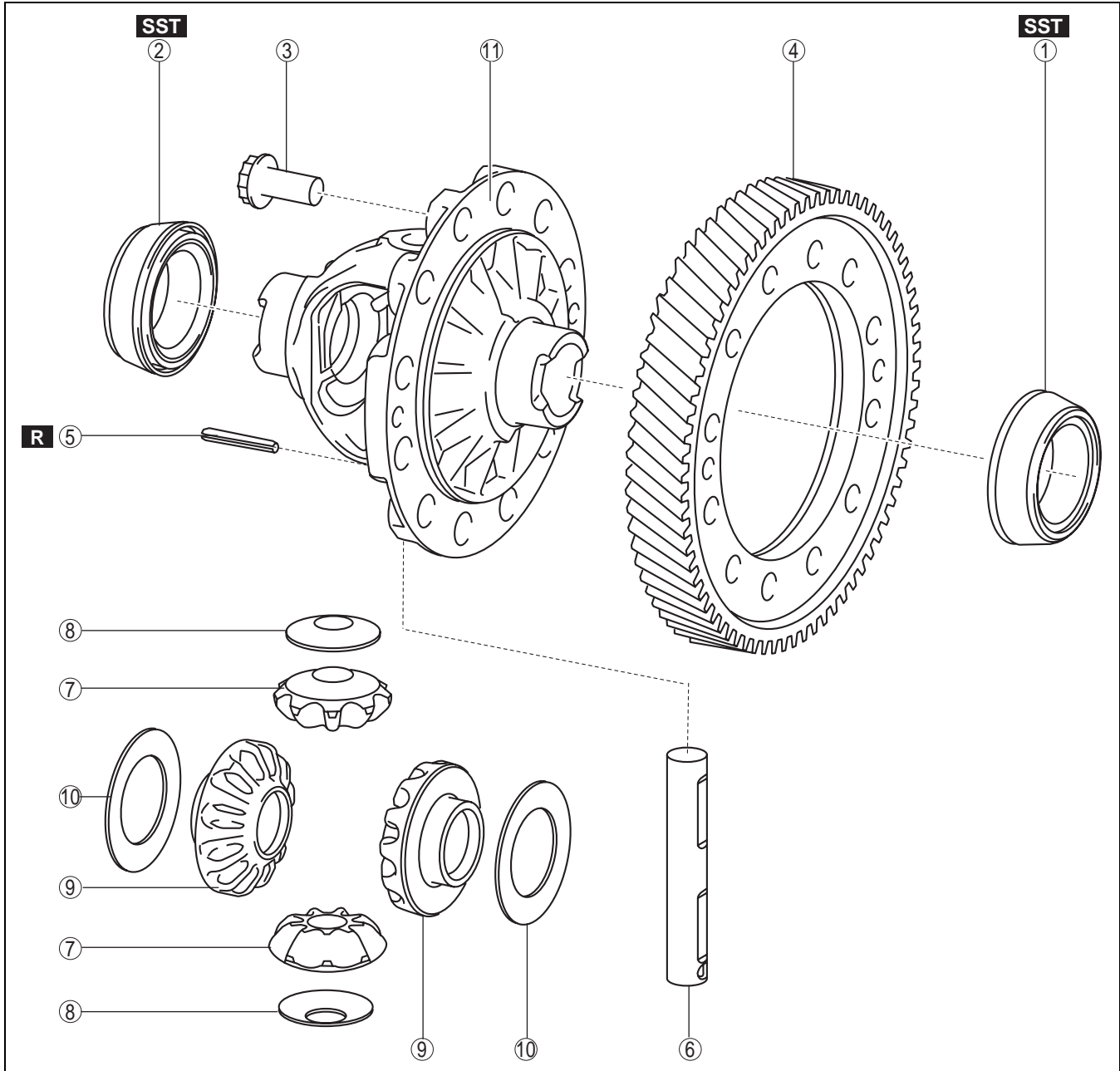

azzjjw00001486

1	Taper roller bearing (transaxle case side)
2	Taper roller bearing (converter housing side)
3	12 bolts
4	Ring gear
5	Roll pin
6	Pinion shaft

7	Pinion gear
8	Thrust washer
9	Side gear
10	Thrust washer
11	Differential gear case

AUTOMATIC TRANSAXLE

Disassembly Procedure

1. Perform the following inspection:

Caution

- If there is no malfunction based on the results of the inspection, it not necessary to disassemble the ring gear and differential.

- Visual inspection of parts (See 05-17-151 VISUAL INSPECTION OF PARTS)
- Ring gear and differential inspection (See 05-17-165 RING GEAR AND DIFFERENTIAL INSPECTION)

- If there is a malfunction, disassemble the ring gear and differential and replace the malfunctioning part with a new part.

2. Remove the taper roller bearing (transaxle case side) using the following procedure:

(1) Secure the ring gear and differential in a vise.

A : Vise

Caution

- Insert a protective plate between the vise and the part so as not to damage the part.

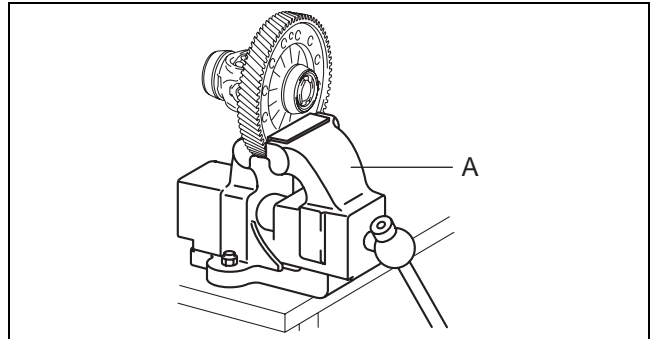

azzjw00001254

(2) Remove the taper roller bearing (transaxle case side) using the SST.

A : Vise

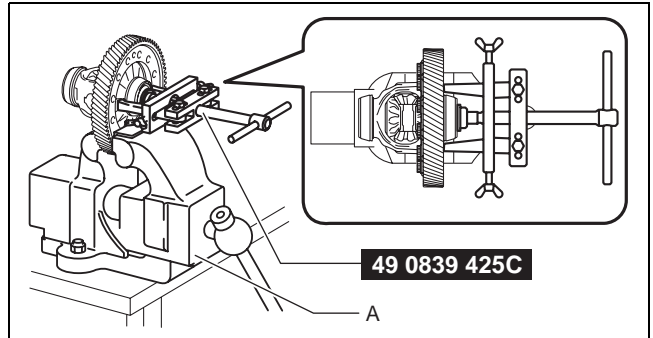

azzjw00000952

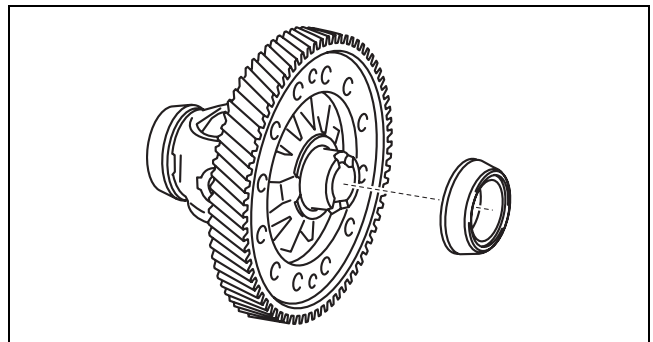

azzjw00000953

AUTOMATIC TRANSAXLE

(3) Remove the ring gear and differential from the vise.

A : Vise

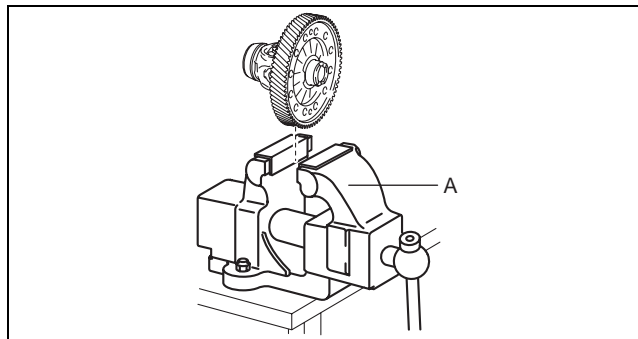

azzjw00001255

05-17

3. Remove the taper roller bearing (converter housing side) using the following procedure:

(1) Secure the ring gear and differential in a vise.

A : Vise

Caution

- Insert a protective plate between the vise and the part so as not to damage the part.

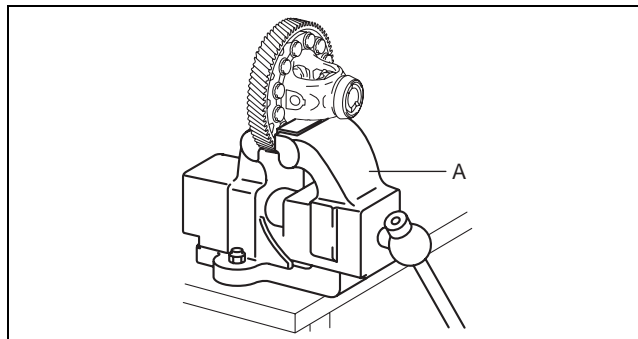

azzjw00001256

(2) Remove the taper roller bearing (converter housing side) using the SST.

A : Vise

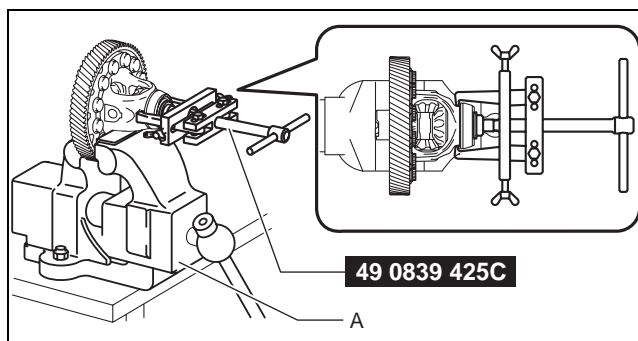

azzjw00000956

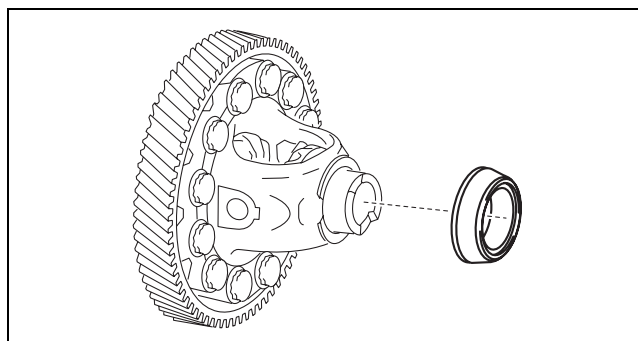

azzjw00000957

AUTOMATIC TRANSAXLE

(3) Remove the ring gear and differential from the vise.

A : Vise

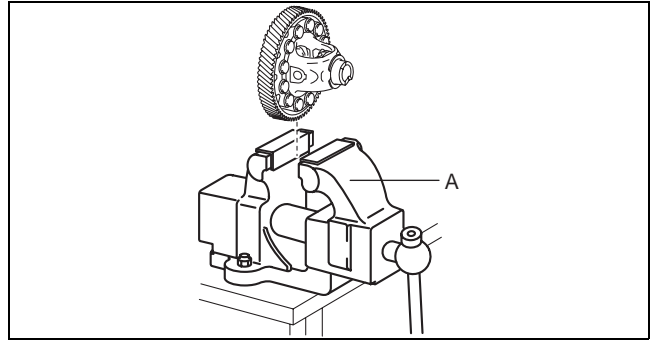

azzjw00000958

4. Remove the ring gear using the following procedure:

1	12 bolts
2	Ring gear

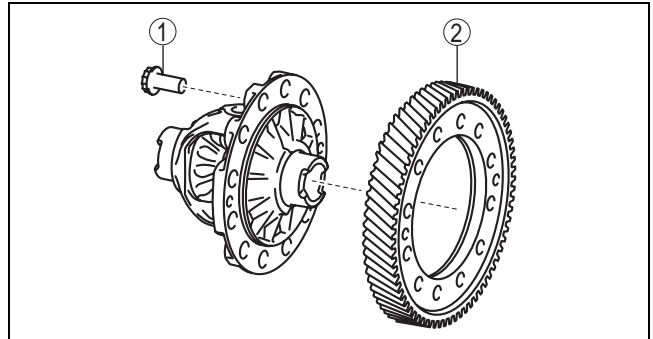

azzjw00000959

(1) Secure the ring gear and differential in a vise.

A : Vise

Caution

- Insert a protective plate between the vise and the part so as not to damage the part.

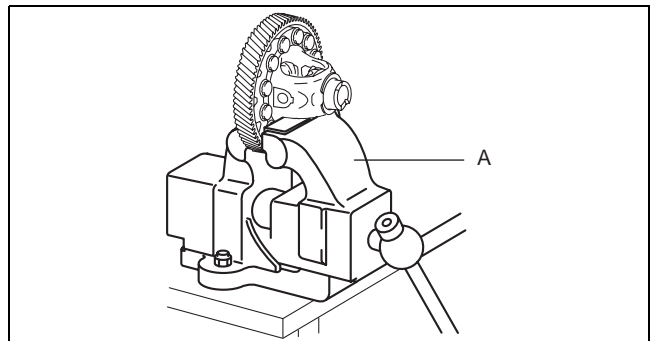

azzjw00000960

(2) Loosen the bolts shown in the figure.

Caution

- Only loosen the bolts, do not remove them, otherwise the ring gear and differential will fall off.

Note

- Change the securing position of the ring gear and differential with the vise and loosen all of the bolts shown in the figure.

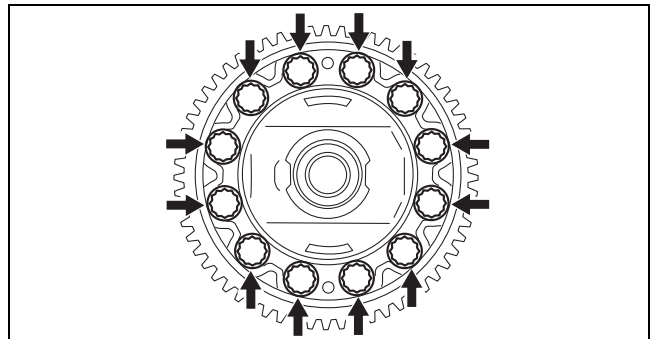

azzjw00000961

AUTOMATIC TRANSAXLE

- (3) Remove the ring gear and differential from the vise.

A : Vise

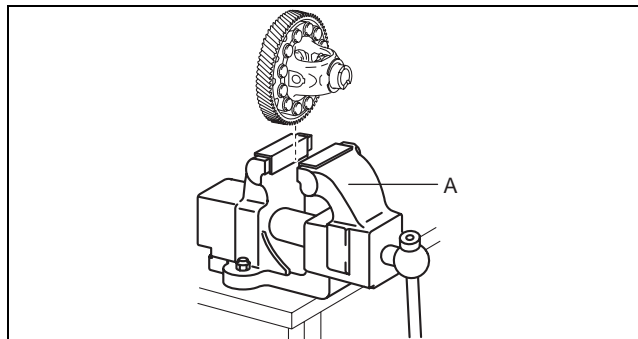

azzjw00000958

- (4) Remove the bolts shown in the figure.

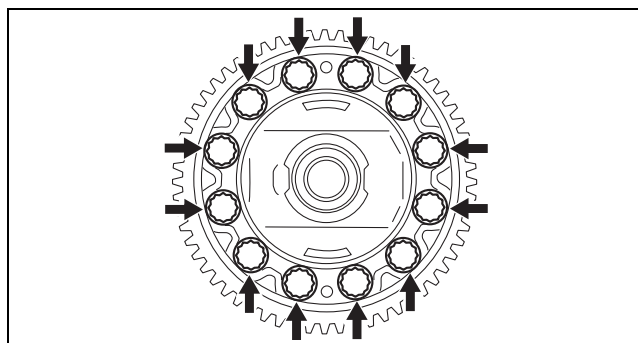

azzjw00000961

- (5) Lightly tap the ring gear with a plastic hammer and remove the ring gear.

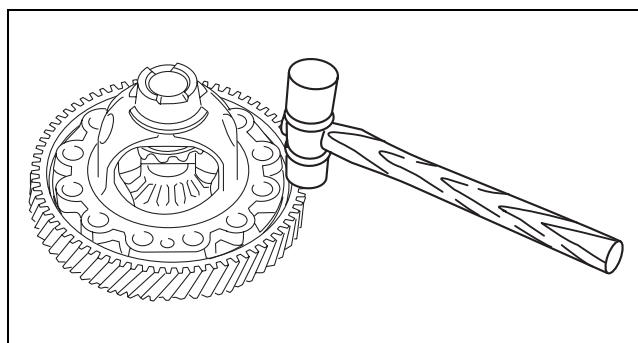

azzjw00000962

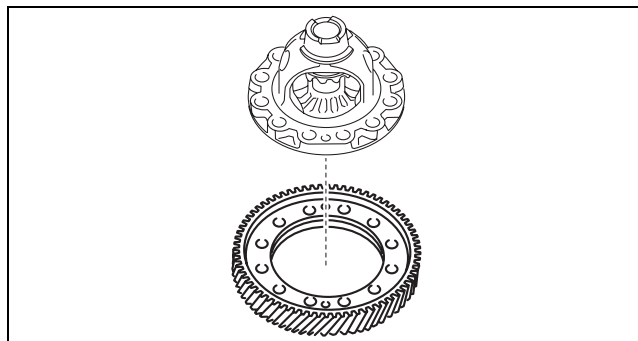

azzjw00000963

05-17

AUTOMATIC TRANSAXLE

5. Remove the roll pin shown in the figure using a pin punch.

Note

- Use a pin punch with an end outer diameter of 3 mm {0.119 in} or more, and within 4 mm {0.157 in}, and an end length of 50 mm {2.0 in} or more.

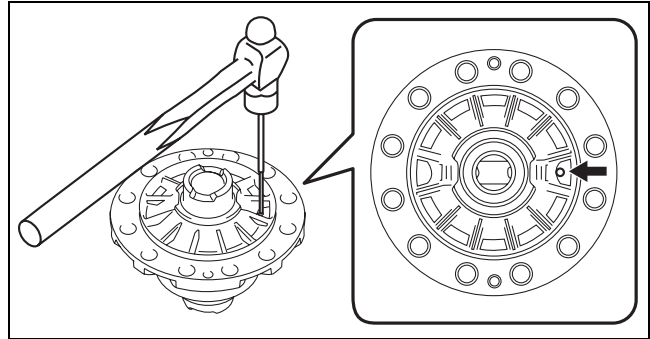

azzjw00001487

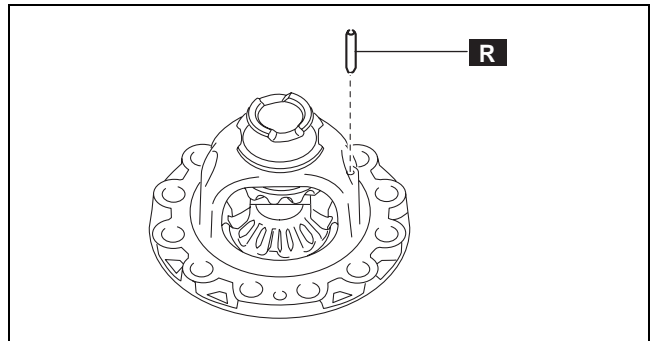

azzjw00001488

6. Remove the pinion shaft.

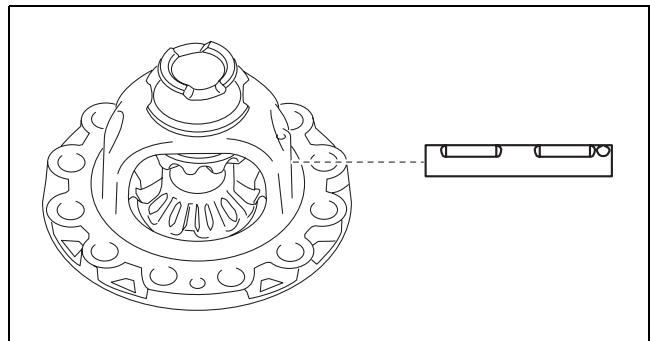

azzjw00001489

7. Remove the pinion gears using the following procedure:
(1) Rotate the pinion gears as shown in the figure.

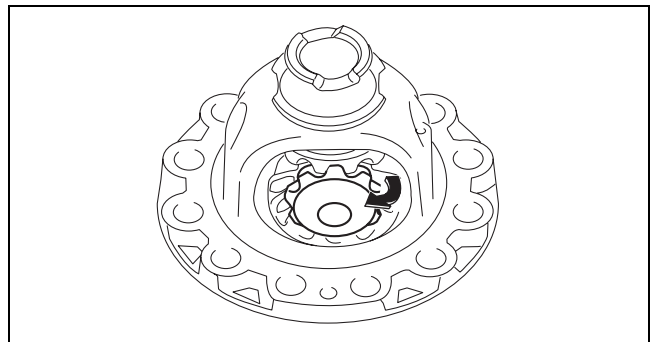

azzjw00001490

AUTOMATIC TRANSAXLE

(2) Remove the pinion gears.

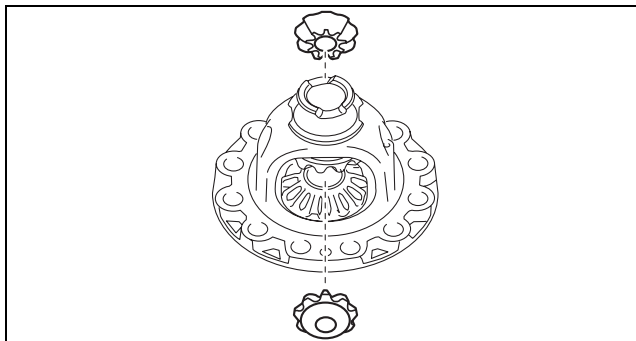

azzjjw00001491

05-17

8. Remove the thrust washers from the pinion gears.

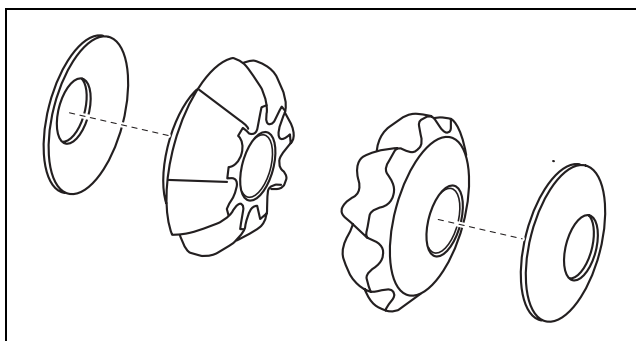

azzjjw00001492

9. Remove the side gears.

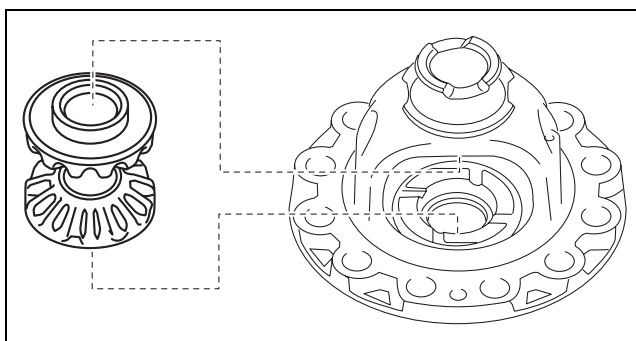

azzjjw00001493

10. Remove the thrust washers from the side gears.

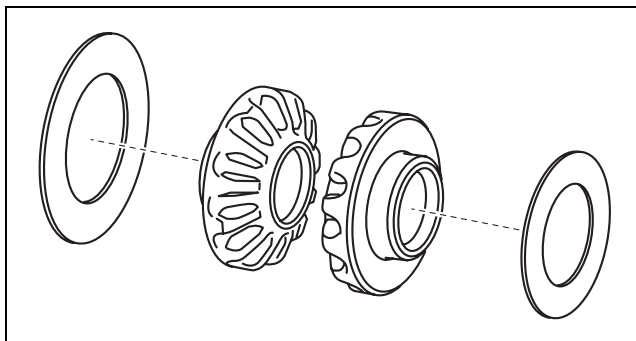

azzjjw00001494

11. Clean the disassembled parts. (See 05-17-26 AUTOMATIC TRANSAXLE CLEANING.)

AUTOMATIC TRANSAXLE

END COVER COMPONENT DISASSEMBLY

id051700661200

Structural View

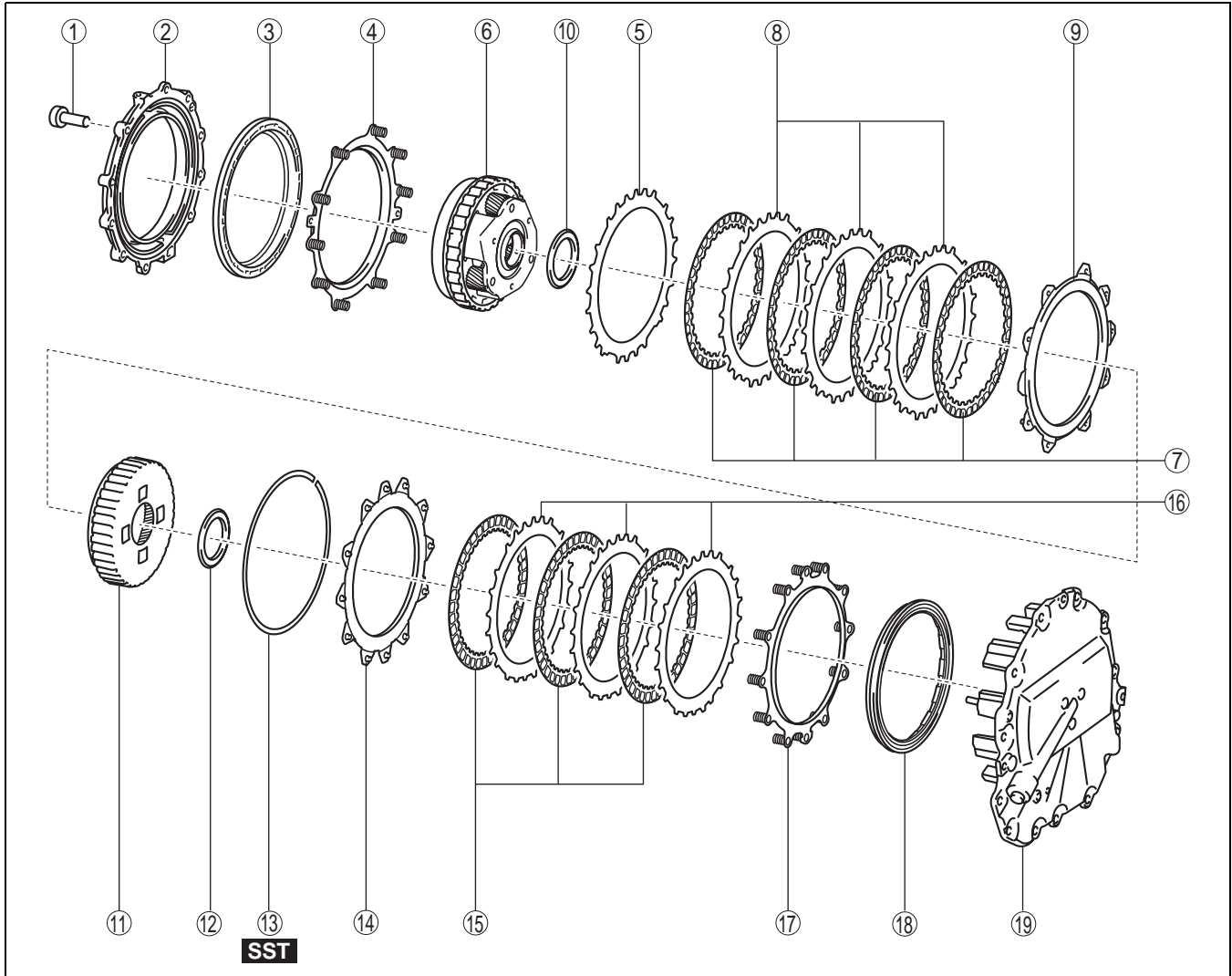

azzjiw00001495

1	8 bolts
2	Brake housing
3	2-6 brake piston
4	Springs and retainer component
5	Retaining plate
6	Reduction planetary gear
7	Drive plate
8	Driven plate
9	Retaining plate
10	Thrust needle bearing

11	Reduction internal gear
12	Thrust needle bearing
13	Snap ring
14	Retaining plate
15	Drive plate
16	Driven plate
17	Springs and retainer component
18	R-3-5 brake piston
19	End cover

AUTOMATIC TRANSAXLE

Disassembly Procedure

1. Perform a simple inspection of the 2-6 brake using the following procedure:

- (1) Blow compressed air into the oil passage shown in the figure and verify the operation condition of the 2-6 brake.

Warning

- Always wear protective eye wear when using the air compressor. Otherwise, ATF or dirt particles blown off by the air compressor could get into the eyes.

Caution

- To prevent damage to parts, always use an air compressor which is adjusted to the indicated pressure.

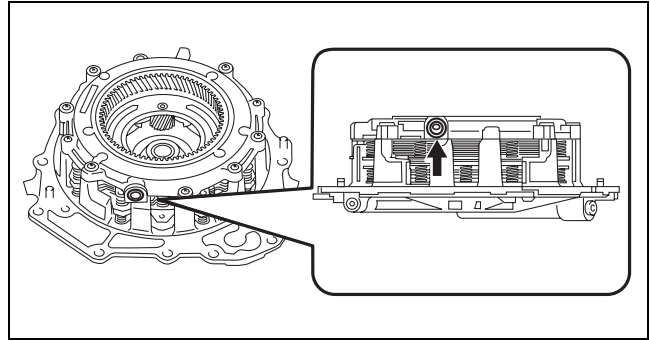

azzjw00000964

05-17

Compressed air pressure

0.39—0.44 MPa {4.0—4.4 kgf/cm², 57—63 psi}

- If there is a malfunction, verify the cause and repair the applicable part after disassembly.

2. Perform a simple inspection of the R-3-5 brake using the following procedure:

- (1) Blow compressed air into the oil passage shown in the figure and verify the operation condition of the R-3-5 brake.

Warning

- Always wear protective eye wear when using the air compressor. Otherwise, ATF or dirt particles blown off by the air compressor could get into the eyes.

Caution

- To prevent damage to parts, always use an air compressor which is adjusted to the indicated pressure.

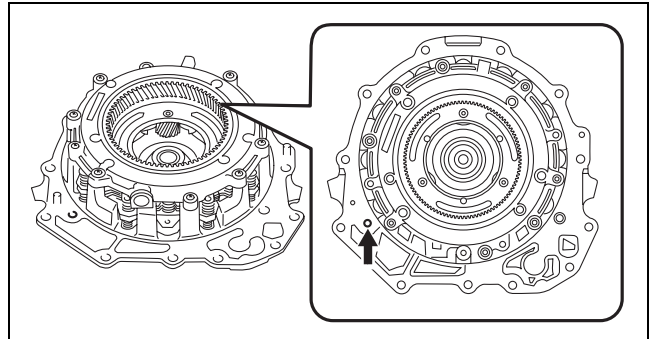

azzjw00000965

Compressed air pressure

0.39—0.44 MPa {4.0—4.4 kgf/cm², 57—63 psi}

- If there is a malfunction, verify the cause and repair the applicable part after disassembly.

3. Remove the brake housing using the following procedure:

1	8 bolts
2	Brake housing

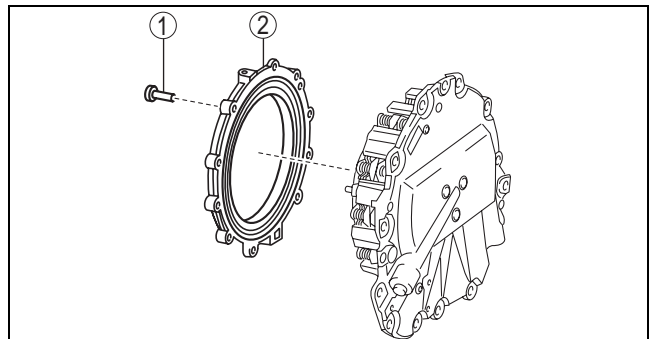

azzjw00000966

AUTOMATIC TRANSAXLE

- (1) Loosen the bolts shown in the figure uniformly and remove them.

Caution

- If the bolts are not loosened uniformly and removed, the brake housing will slant and parts could be damaged due to the spring force of the springs and retainer component in the brake housing.

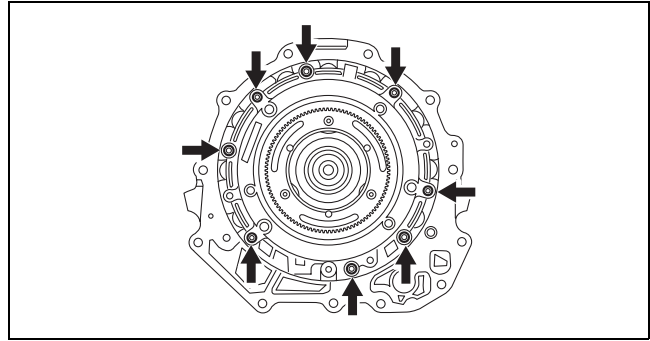

azzjiw00000967

- (2) Remove the brake housing.

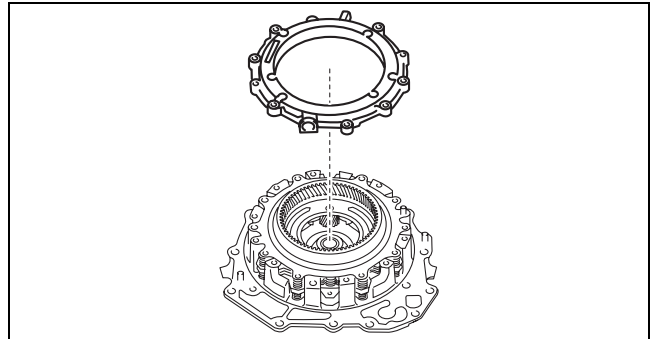

azzjiw00000968

4. Remove the 2-6 brake piston from the brake housing using the following procedure:

- (1) Blow compressed air into the oil passage shown in the figure.

Warning

- Always wear protective eye wear when using the air compressor. Otherwise, ATF or dirt particles blown off by the air compressor could get into the eyes.

Caution

- To prevent damage to parts, always use an air compressor which is adjusted to the indicated pressure.

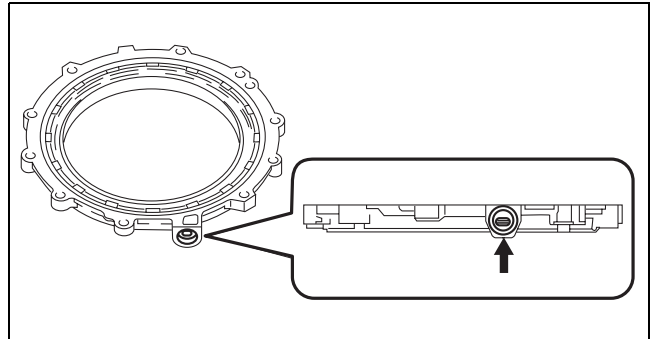

azzjiw00000969

Compressed air pressure

0.39—0.44 MPa {4.0—4.4 kgf/cm², 57—63 psi}

- (2) Remove the 2-6 brake piston removed from the brake housing.

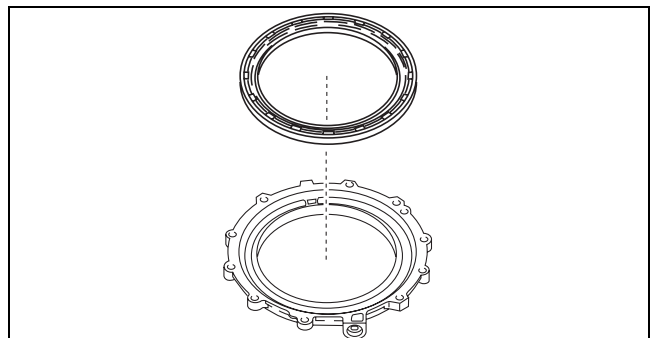

azzjiw00000970

AUTOMATIC TRANSAXLE

5. Remove the springs and retainer component.

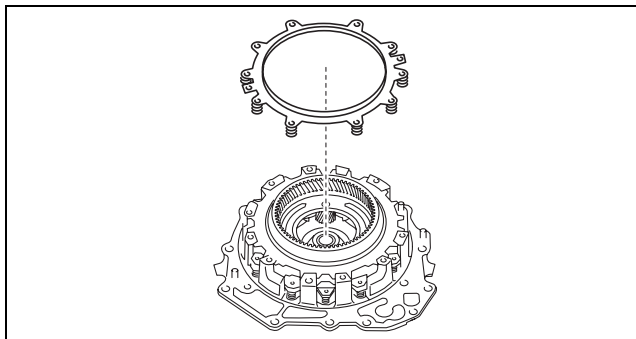

azzjjw00000971

6. Remove the retaining plate.

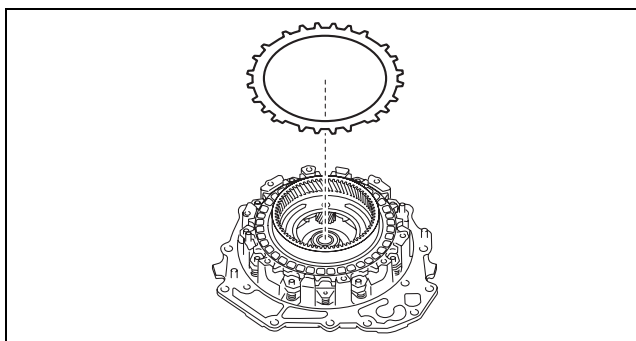

azzjjw00001200

7. Remove the reduction planetary gear.

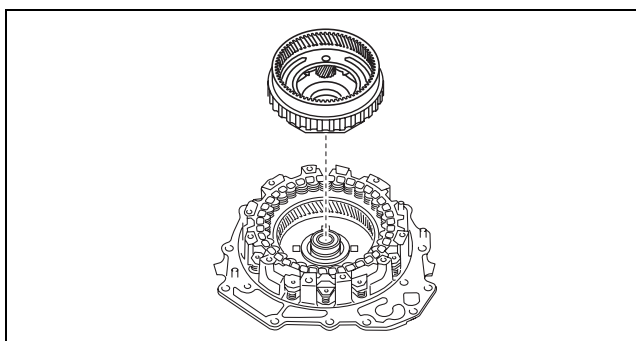

azzjjw00000973

8. Remove the drive plates and driven plates.

A : Drive plate
B : Driven plate

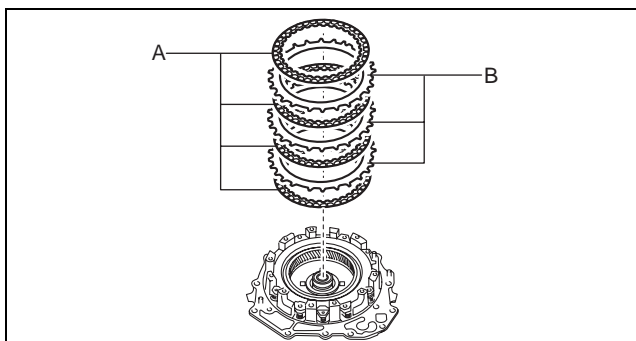

azzjjw00000974

05-17

AUTOMATIC TRANSAXLE

9. Remove the retaining plate.

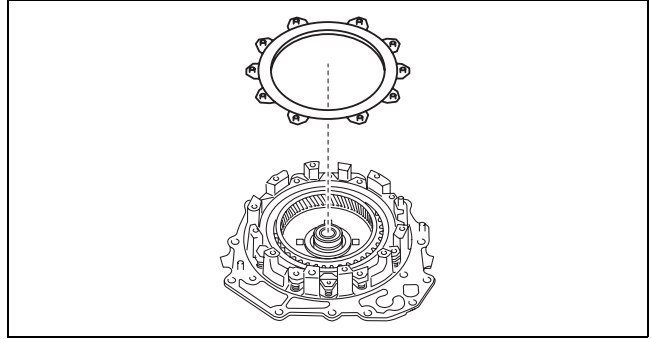

azzjw00000975

10. Remove the thrust needle bearing.

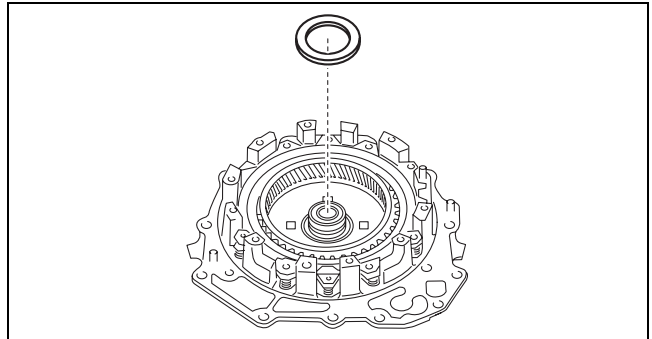

azzjw00000976

11. Remove the reduction internal gear.

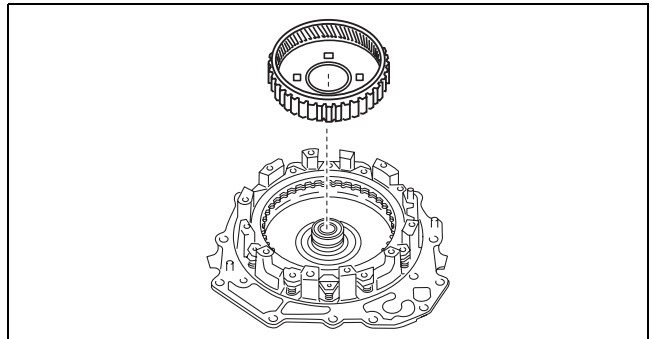

azzjw00000977

12. Remove the thrust needle bearing.

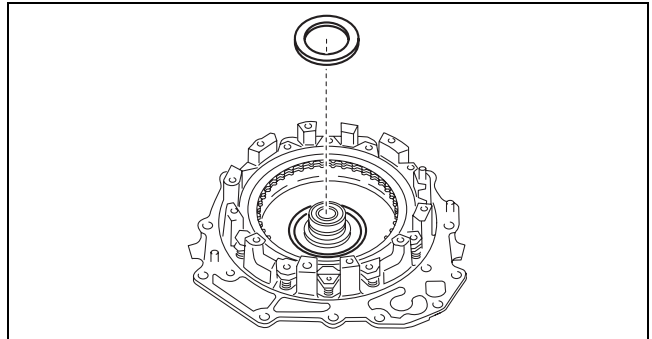

azzjw00000978

AUTOMATIC TRANSAXLE

13. Remove the snap ring using the following procedure:
 (1) Install the SST.

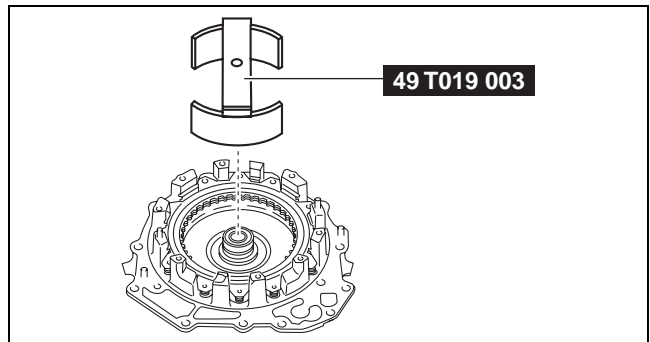

azzijw0000979

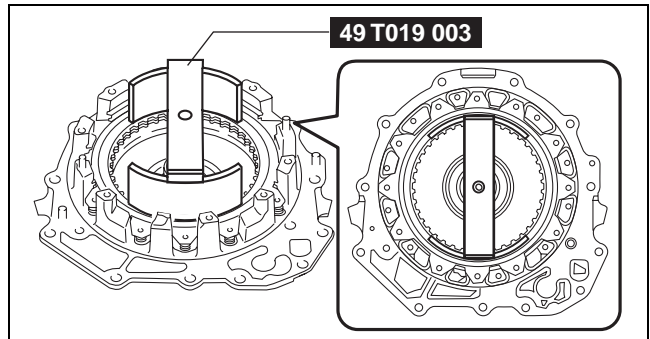

azzijw00001201

- (2) Set the SST and part to the press as shown in the figure.

- A : Press
 B : Rubber plate

Caution

- Using the rubber plates, adjust the alignment surface of the end cover with the transaxle case so that it is level. Otherwise the parts could tip over during the procedure and get damaged.

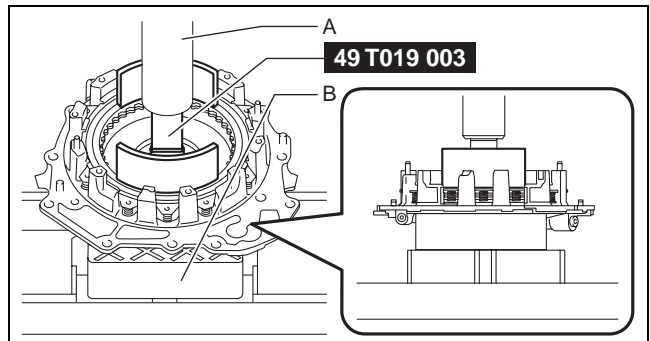

azzijw00000981

- (3) Press the SST down using a press until there is no longer any spring force from the springs and retainer component applied to the snap ring.

- A : Snap ring
 B : Retaining plate
 C : Gap

Caution

- If the SST is pressed excessively by the press, surrounding parts could be damaged. Stop pressing the SST down using a press if a gap appears between the snap ring and retaining plate.

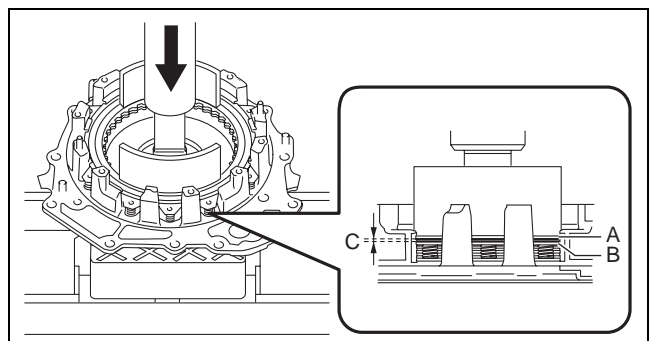

azzijw00000982

05-17

AUTOMATIC TRANSAXLE

- (4) Remove the snap ring from the snap ring groove.

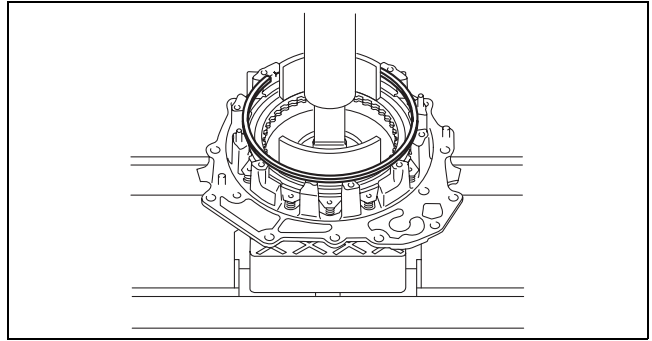

azzjw00000983

- (5) Take the SST and part off the press.

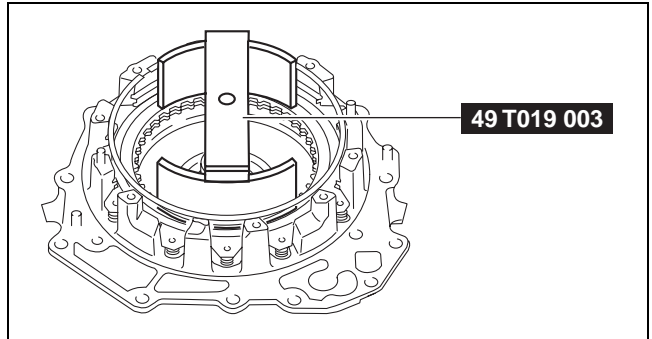

azzjw00000984

- (6) Remove the SST.

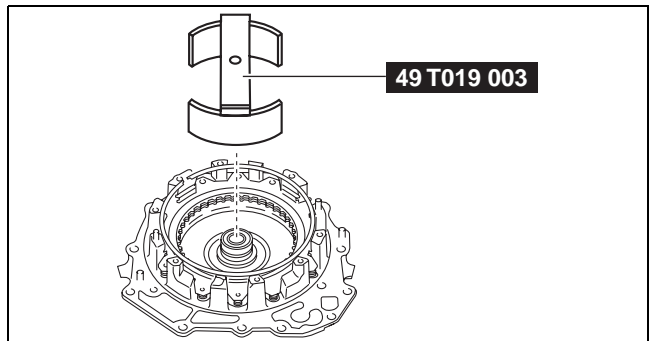

azzjw00000985

- (7) Remove the snap ring removed from the snap ring groove.

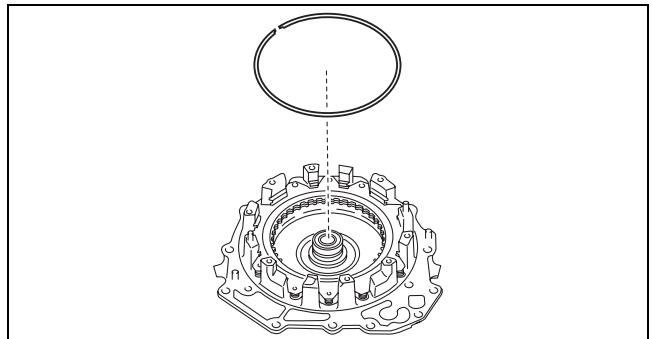

azzjw00000986

AUTOMATIC TRANSAXLE

14. Remove the retaining plate.

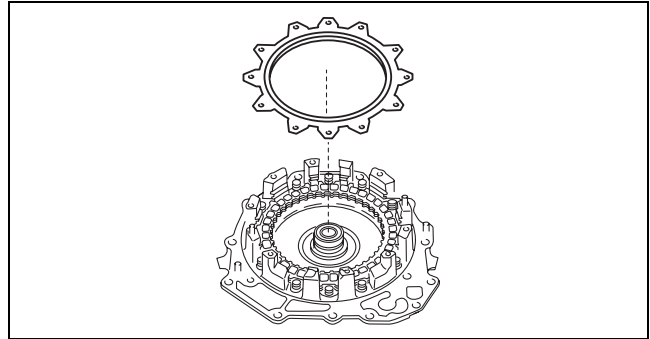

azzjw00000987

15. Remove the drive plates and driven plates.

- A : Drive plate
- B : Driven plate

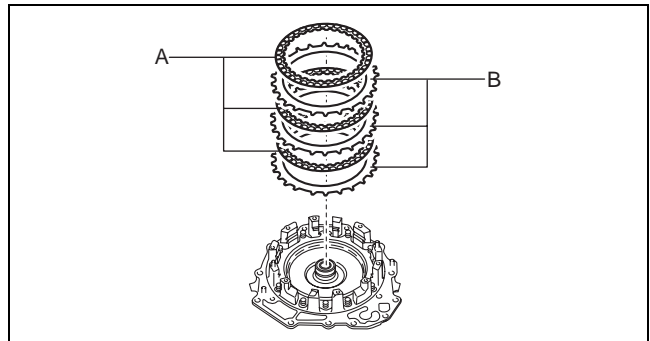

azzjw00000988

16. Remove the springs and retainer component.

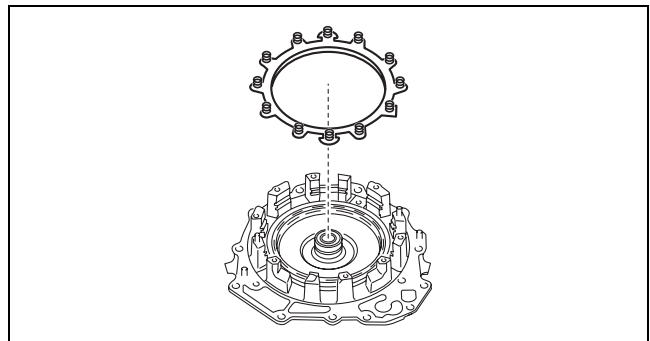

azzjw00000989

17. Remove the R-3-5 brake piston using the following procedure:

- (1) Blow compressed air into the oil passage shown in the figure.

Warning

- Always wear protective eye wear when using the air compressor. Otherwise, ATF or dirt particles blown off by the air compressor could get into the eyes.

Caution

- To prevent damage to parts, always use an air compressor which is adjusted to the indicated pressure.

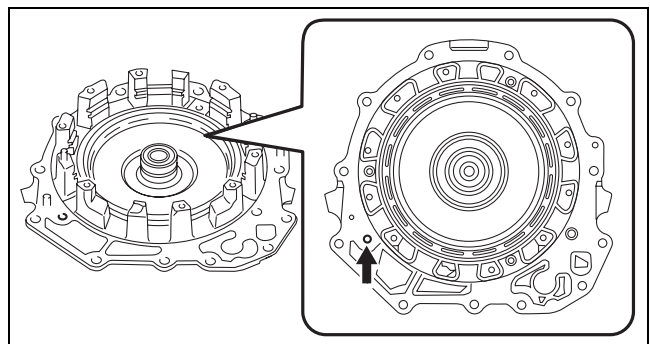

azzjw00000990

Compressed air pressure

0.39—0.44 MPa {4.0—4.4 kgf/cm², 57—63 psi}

AUTOMATIC TRANSAXLE

(2) Remove the R-3-5 brake piston removed from the end cover.

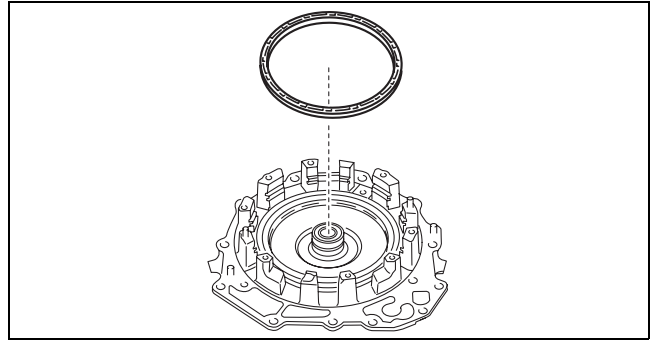

azzjiw00000991

18. Clean the disassembled parts. (See 05-17-26 AUTOMATIC TRANSAXLE CLEANING.)

19. Perform the following inspection and replace a malfunctioning part with a new one.

- Visual inspection of parts (See 05-17-151 VISUAL INSPECTION OF PARTS)
- Thrust needle bearing inspection (See 05-17-155 THRUST NEEDLE BEARING INSPECTION)
- Reduction planetary gear inspection (See 05-17-161 REDUCTION PLANETARY GEAR INSPECTION)
- 2-6 brake inspection (See 05-17-171 2-6 BRAKE INSPECTION)
- R-3-5 brake inspection (See 05-17-171 R-3-5 BRAKE INSPECTION)
- End cover inspection (See 05-17-177 END COVER INSPECTION)

REDUCTION PLANETARY GEAR DISASSEMBLY

id051700661300

Structural View

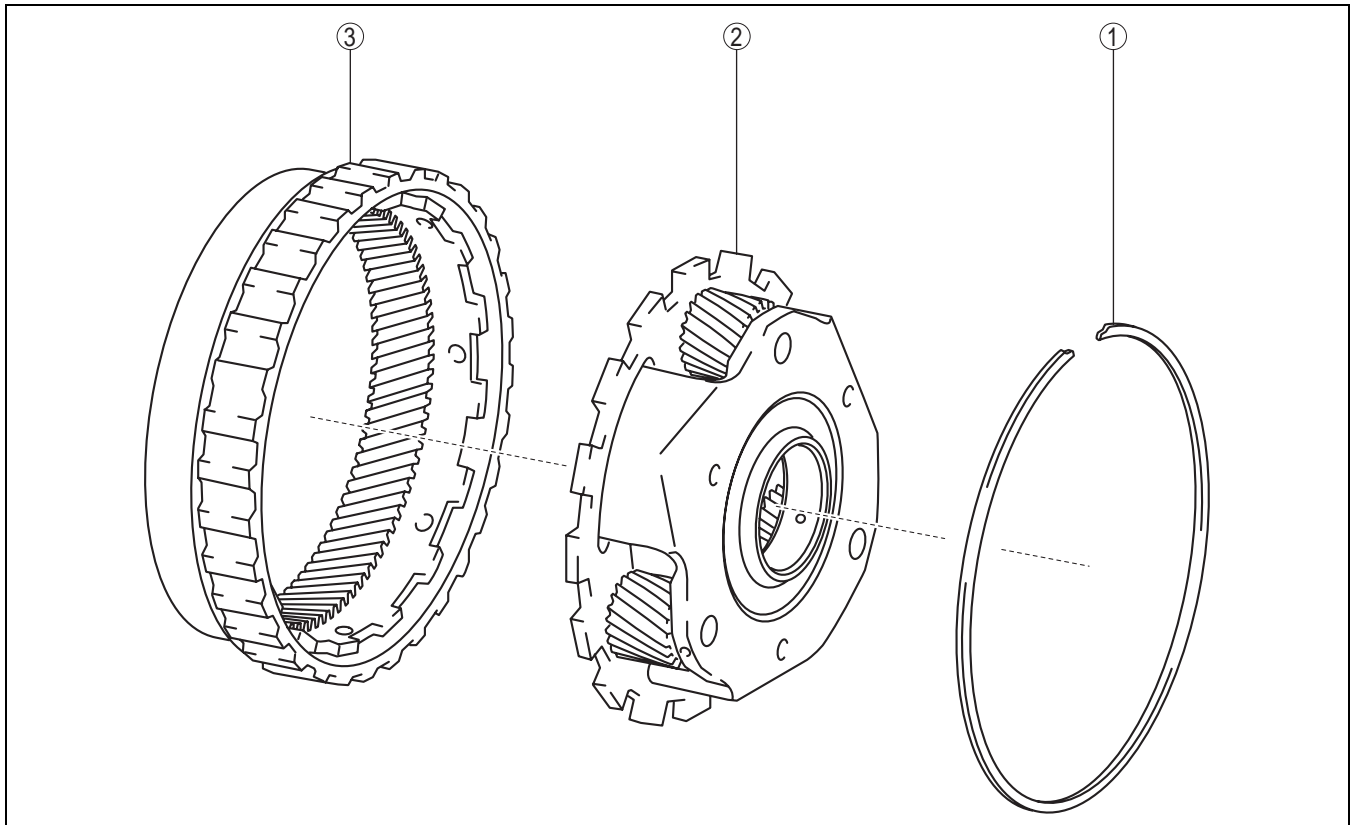

azzjiw00001496

1	Snap ring
2	Reduction planetary carrier

3	Rear internal gear
---	--------------------

AUTOMATIC TRANSAXLE

Disassembly Procedure

1. Perform the following inspection:

Caution

- If there is no malfunction based on the results of the inspection, it is not necessary to disassemble the reduction planetary gear.
- Visual inspection of parts (See 05-17-151 VISUAL INSPECTION OF PARTS)
- Reduction planetary gear inspection (See 05-17-161 REDUCTION PLANETARY GEAR INSPECTION)
- If there is a malfunction, disassemble the reduction planetary gear and replace the malfunctioning part with a new part.

2. Remove the snap ring.

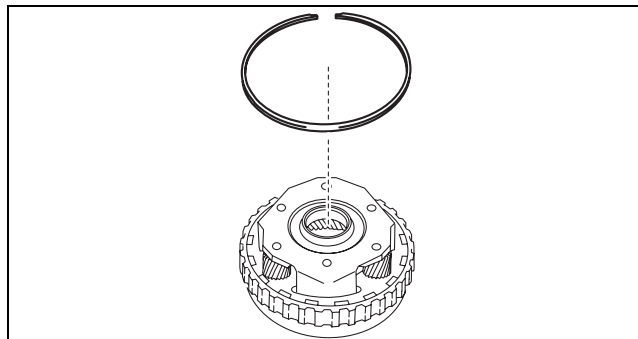

azzjw00000872

3. Remove the reduction planetary carrier.

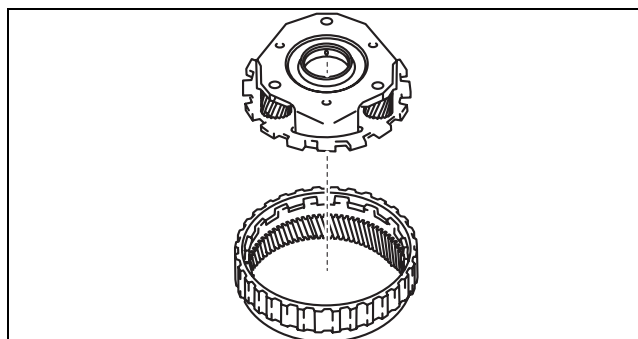

azzjw00000873

4. Clean the disassembled parts. (See 05-17-26 AUTOMATIC TRANSAXLE CLEANING.)

AUTOMATIC TRANSAXLE

CONTROL VALVE BODY DISASSEMBLY

id051700661400

Structural View

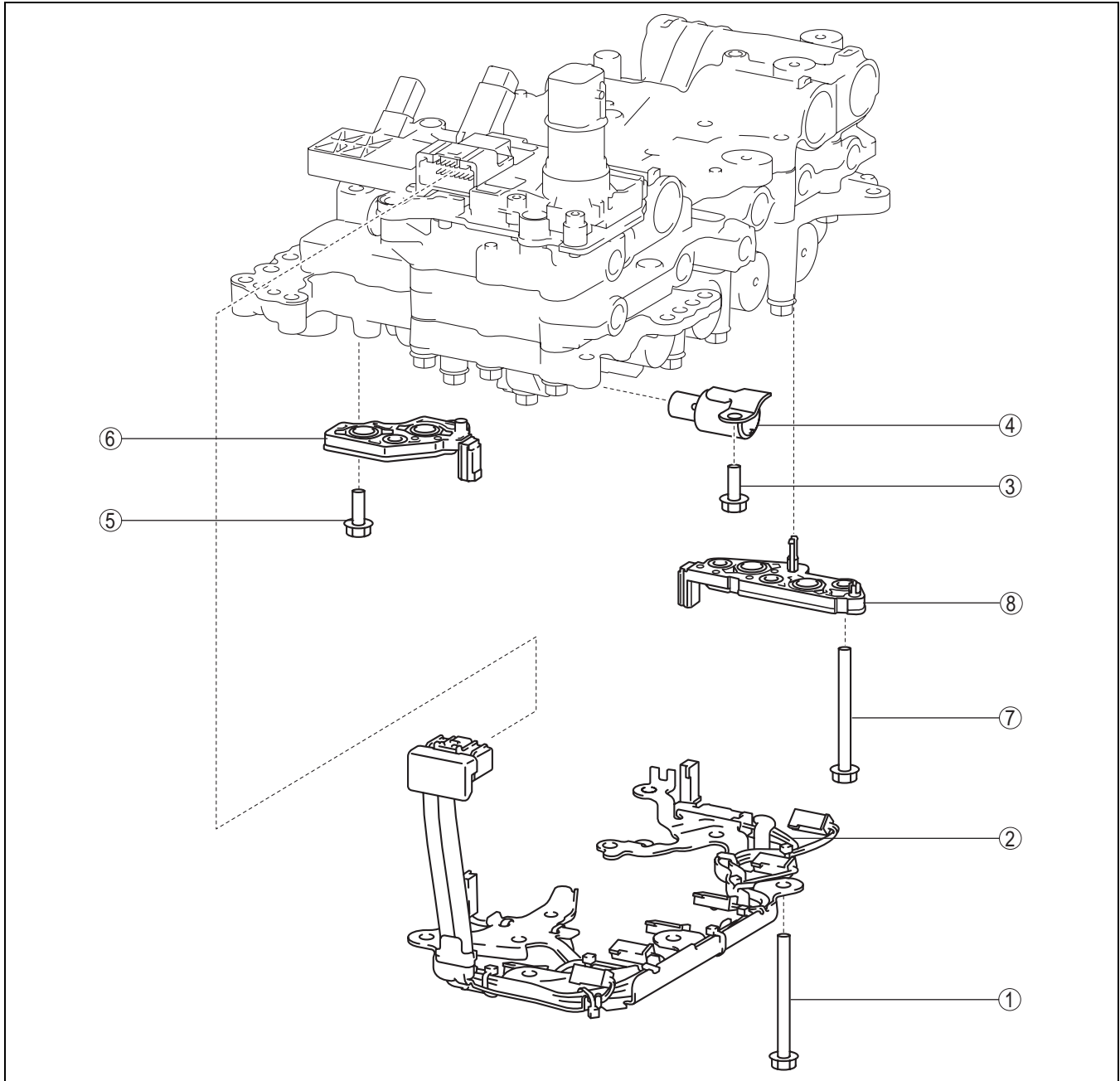

azzjiw00001499

1	8 bolts
2	Coupler component
3	Bolt
4	ON/OFF solenoid

5	3 bolts
6	Oil pressure switch B
7	3 bolts
8	Oil pressure switch A

AUTOMATIC TRANSAXLE

Disassembly Procedure

Caution

- Disassemble the control valve body and replace the malfunctioning part only if there is a malfunction in the control valve body determined by the troubleshooting procedure and using the vehicle diagnostic tester (M-MDS). However, if there is a malfunction in the parts other than the following, replace the control valve body with a new one because the parts other than the following are not shipped from the factory as a single component.
 - ON/OFF solenoid
 - Oil pressure switch A
 - Oil pressure switch B
 - Coupler component
- Do not drop or apply an impact to the control valve body. Replace the control valve body with a new one if it was dropped or received an impact.
- Placing the TCM side pointed downward on a workbench directly could damage the TCM. If the TCM side is placed pointed downward, place the control valve body on an impact-absorbing material so that the TCM does not contact the workbench directly.
 - A: TCM
 - B: Impact-absorbing material

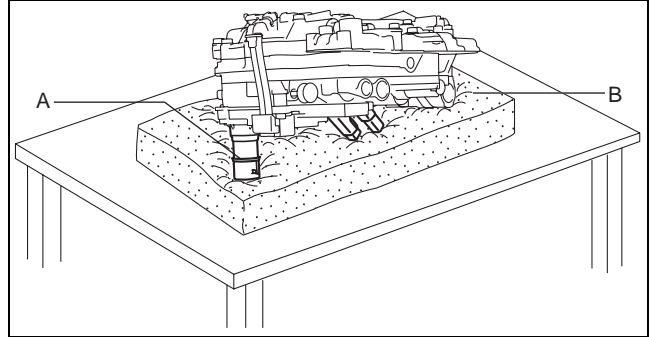

azzjw00001500

1. Remove the coupler component using the following procedure.

1	8 bolts
2	Coupler component

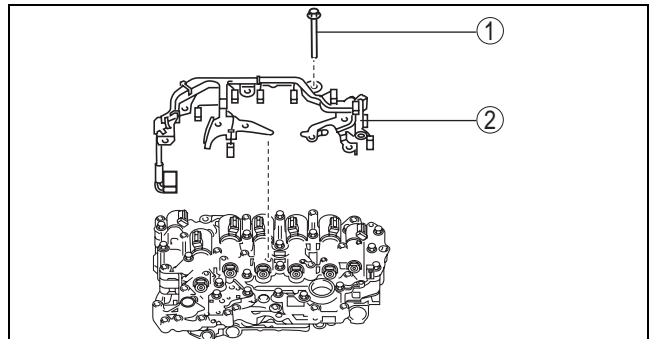

azzjw00000900

AUTOMATIC TRANSAXLE

(1) Disconnect the connector shown in the figure.

Caution

- If a connector is disconnected, do not pull the wiring harness. Pull the connector at a straight after releasing the lock.

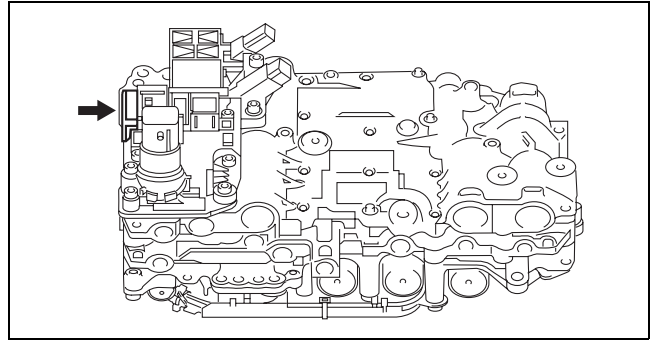

azzjiw00000896

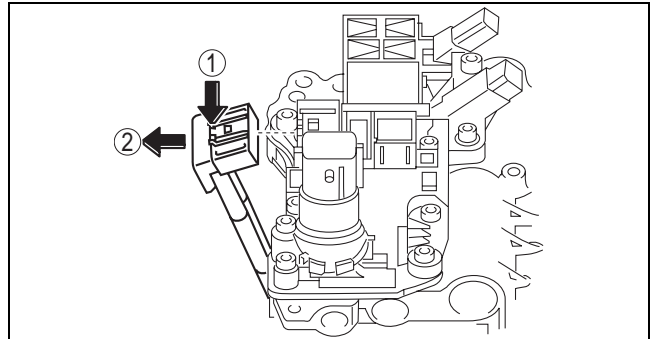

azzjiw00000897

(2) Place the control valve body on an impact-absorbing material with the TCM side facing downward as shown in the figure.

- A : TCM
- B : Impact-absorbing material

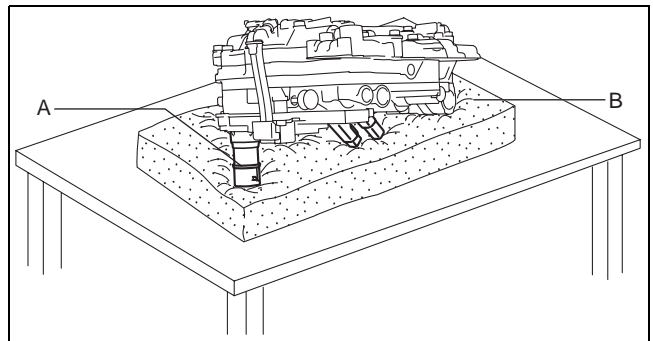

azzjiw00001500

Caution

- Placing the TCM side pointed downward on a workbench directly could damage the TCM. If the TCM side is placed pointed downward, place the control valve body on an impact-absorbing material so that the TCM does not contact the workbench directly.
- After removing the coupler component, if the control valve body is placed on the workbench with the TCM side facing upward, the pins securing the solenoids shown in the figure could fall off and become lost.

If the solenoid installation position shown in the figure is changed, it will cause a malfunction. To prevent the pin securing the solenoid from falling, always place the control valve body on an impact-absorbing material with the TCM side facing downward after removing the coupler component.

- A : Shift solenoid No.1
- B : Shift solenoid No.4
- C : TCC control solenoid
- D : Shift solenoid No.3
- E : Shift solenoid No.2
- F : Pressure control solenoid

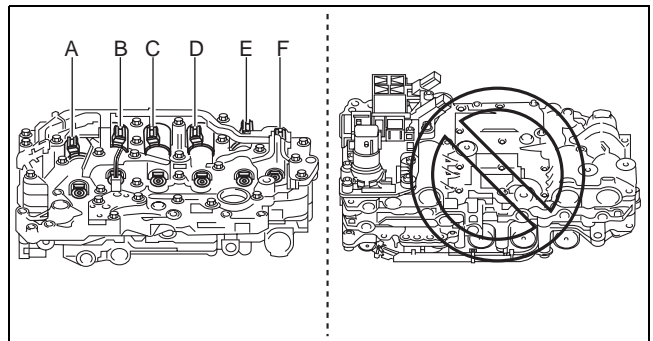

azzjiw00001501

AUTOMATIC TRANSAXLE

(3) Remove the bolts shown in the figure.

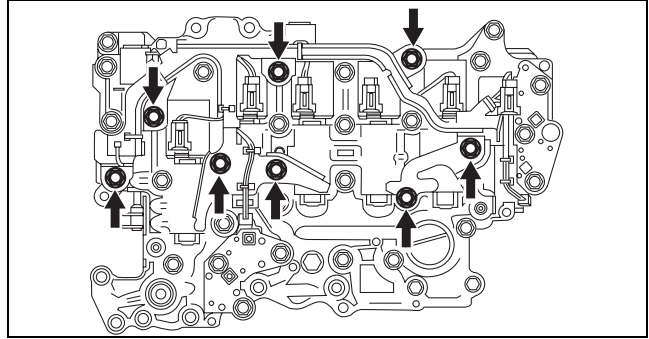

azzjw00000902

(4) Disconnect the connectors shown in the figure.

Caution

- If a connector is disconnected, do not pull the wiring harness. Pull the connector at a straight after releasing the lock.

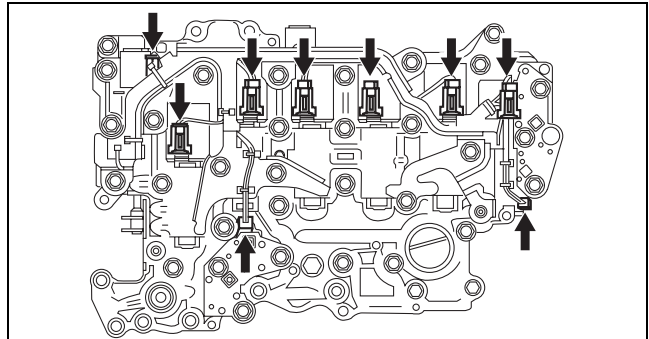

azzjw00000903

Caution

- For the connector shown in the figure, pull the connector at a straight after releasing the lock using a precision flathead screwdriver.

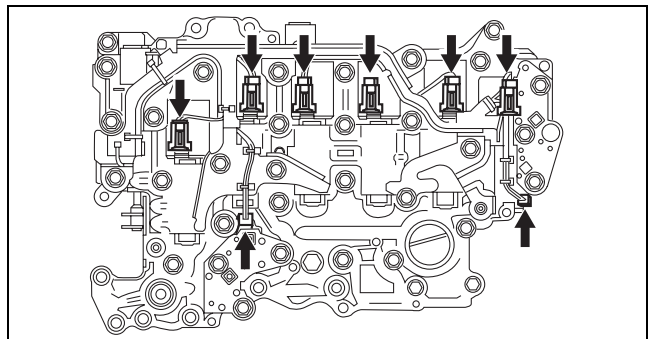

azzjw00000904

Caution

- Be careful not to damage the connector using a precision flathead screwdriver.

A : Precision flathead screwdriver

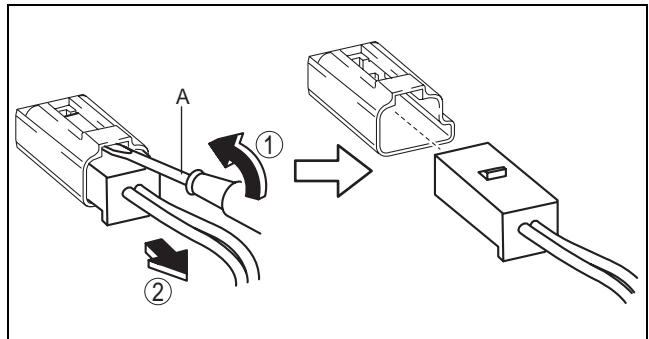

azzjw00000905

AUTOMATIC TRANSAXLE

(5) Remove the coupler component.

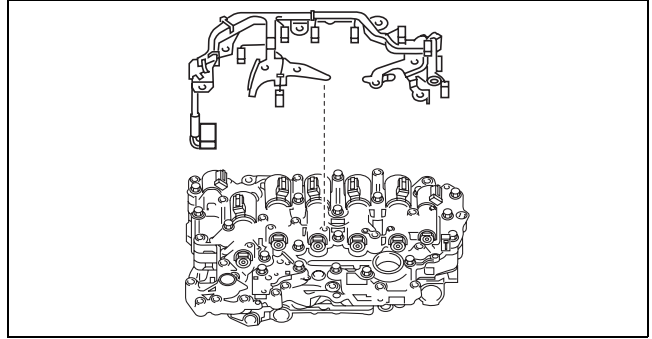

azzjw00000906

2. Remove the ON/OFF solenoid using the following procedure:

1	Bolt
2	ON/OFF solenoid

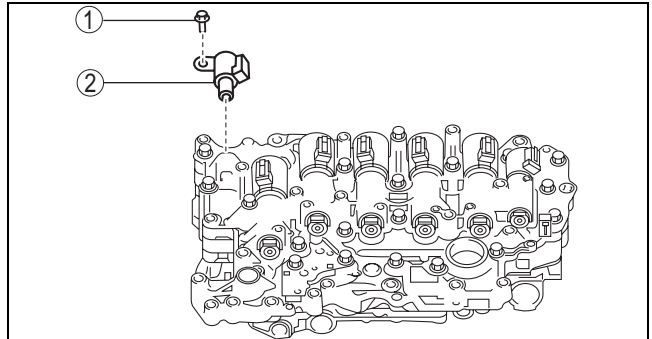

azzjw00000907

(1) Remove the bolt shown in the figure.

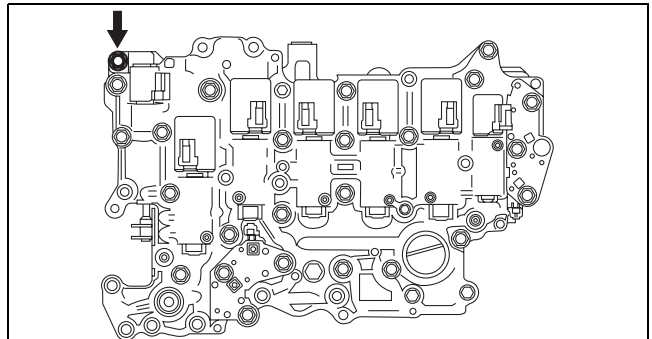

azzjw00000908

(2) Remove the ON/OFF solenoid.

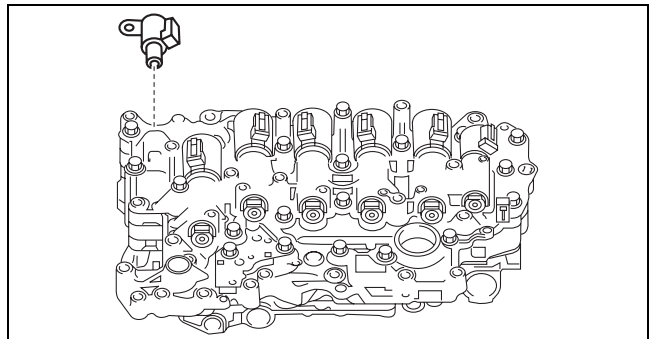

azzjw00000909

AUTOMATIC TRANSAXLE

3. Remove oil pressure switch B using the following procedure:

1	3 bolts
2	Oil pressure switch B

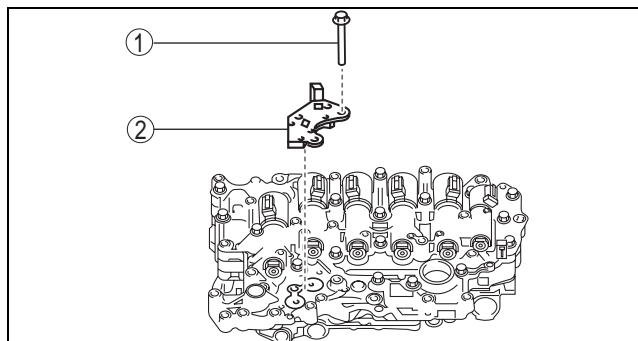

azzjw00000910

(1) Remove the bolts shown in the figure.

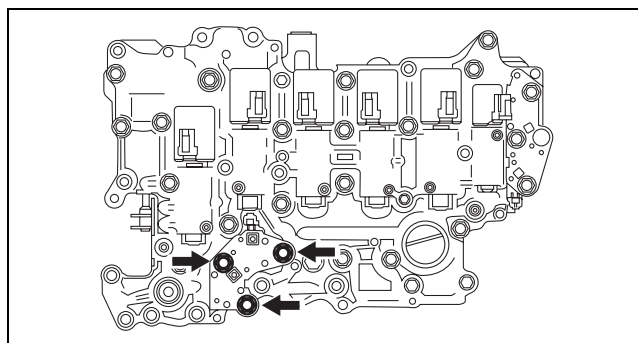

azzjw00000911

(2) Remove oil pressure switch B.

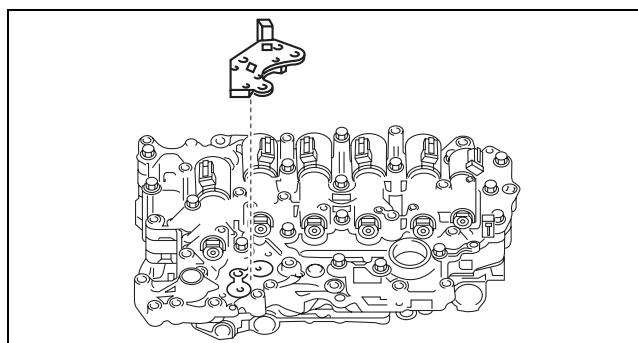

azzjw00000912

4. Remove oil pressure switch A using the following procedure:

1	3 bolts
2	Oil pressure switch A

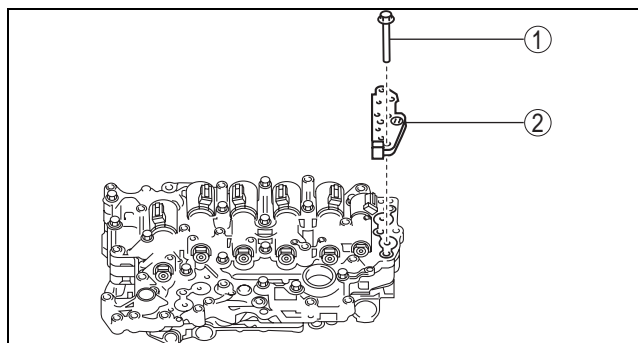

azzjw00000913

05-17

AUTOMATIC TRANSAXLE

(1) Remove the bolts shown in the figure.

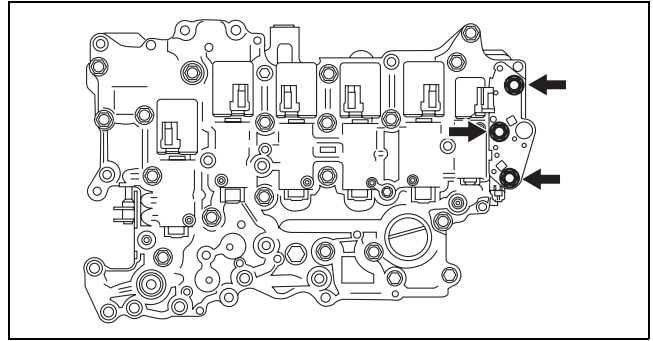

azzjw00000914

(2) Disengage oil pressure switch A tab.

A : Tab

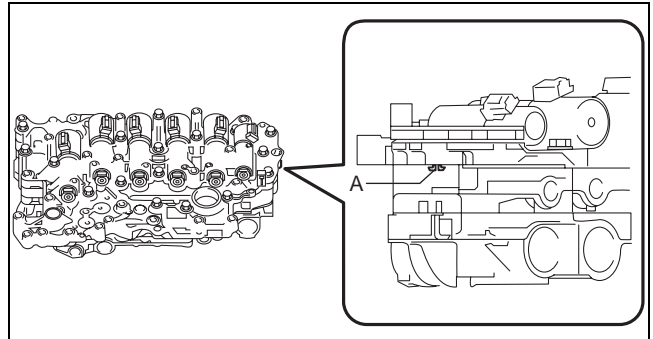

azzjw00000915

(3) Remove oil pressure switch A.

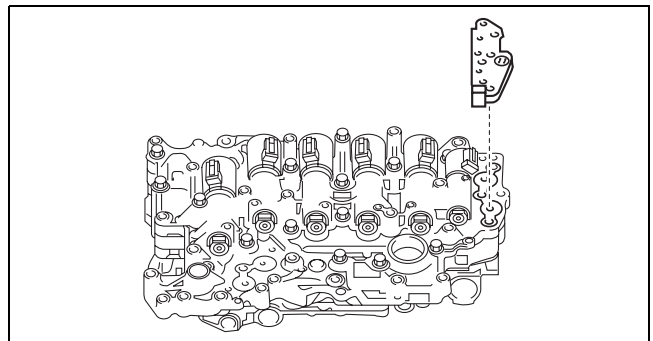

azzjw00000916

AUTOMATIC TRANSAXLE

TORQUE CONVERTER CLEANING

id051700661500

Cleaning Outside of Torque Converter

1. Plug to the position shown in the figure with packing tape.

A : Plug (packing tape)

Caution

- If foreign matter penetrates the torque converter, it could cause a malfunction. Therefore, when cleaning the outside of the torque converter, plug the position shown in the figure with packing tape.

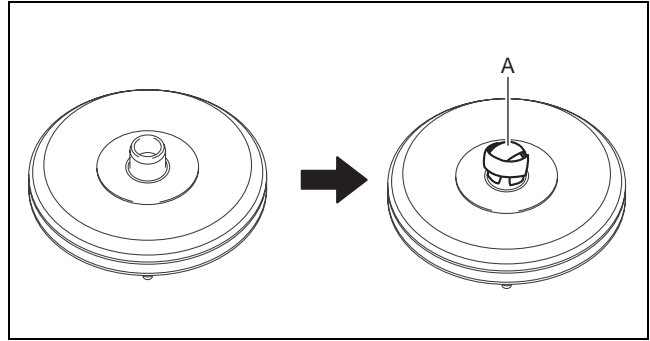

azzjw00001502

05-17

2. Wipe off any dirt or foreign matter adhering to the outside of the torque converter using a rag. Clean depending on the condition using degreaser and dry them using an air compressor.

Warning

- Always wear protective eye wear when using the air compressor. Otherwise, degreaser or dirt particles blown off by the air compressor could get into the eyes.

3. Clean away the used packing tape as a plug.

A : Plug (packing tape)

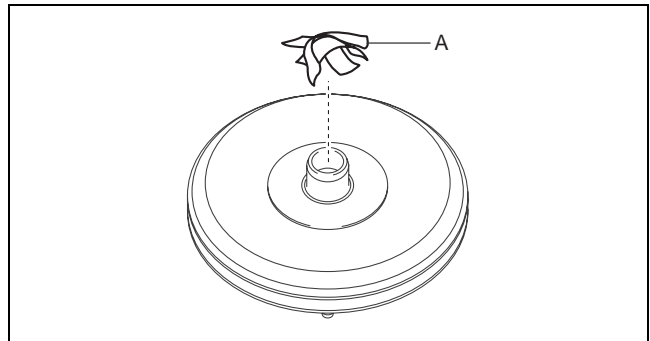

azzjw00001503

Torque Converter Flushing

1. Prepare a clean oil receptacle.

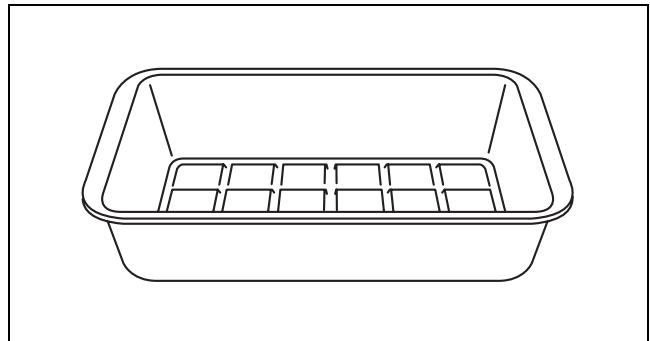

azzjw00001062

AUTOMATIC TRANSAXLE

2. Add new ATF (ATF FZ) to the torque converter from the position shown in the figure.

Note

- Because the ATF in the torque converter needs to be well stirred, when adding ATF do not completely fill the torque converter. Fill only about halfway.

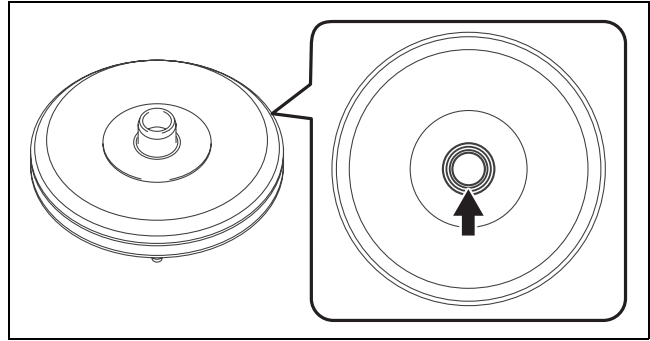

azzjw00001063

3. Shake the torque converter to stir the ATF in the torque converter.

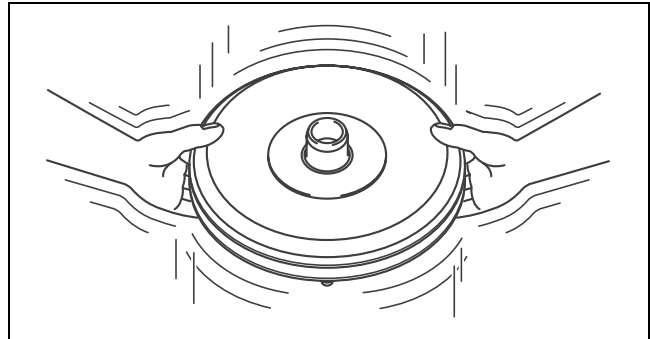

azzjw00001064

4. Drain the ATF in the torque converter into the clean oil receptacle.

Note

- While shaking the torque converter, drain as much of the ATF in the torque converter as possible.

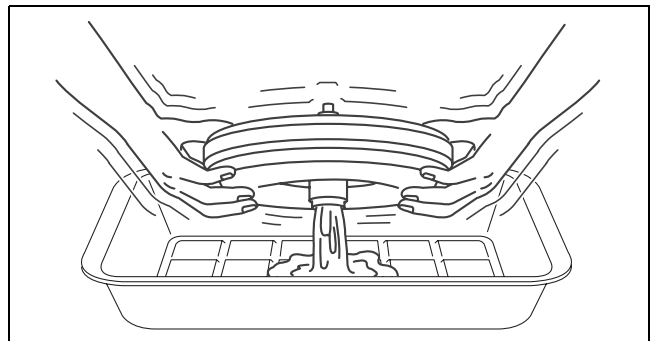

azzjw00001065

5. Verify that none of the following foreign material is mixed in with the ATF drained from the torque converter:
 - Large metal fragments of ϕ 0.5 mm {0.02 in} or more that cannot pass through the oil strainer
 - Fibrous clutch or brake facing
6. Dispose of the ATF in the oil receptacle and clean the oil receptacle.
7. Perform Steps 2—6 three times.
 - If metal fragments and facing material continue to appear in the drained ATF from the torque converter after it is flushed repeatedly, replace the torque converter with a new one.

AUTOMATIC TRANSAXLE

OIL COOLER CLEANING

id051700661600

Cleaning Outside of Oil Cooler

1. Plug to the position shown in the figure with packing tape.

A : Plug (packing tape)

Caution

- If foreign matter penetrates the oil cooler, it could cause a malfunction. Therefore, when cleaning the outside of the oil cooler, plug the position shown in the figure with packing tape.

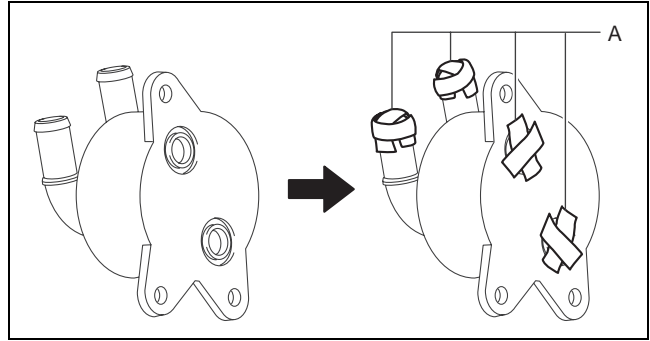

azzjw00001504

05-17

2. Wipe off any dirt or foreign matter adhering to the outside of the oil cooler using a rag. Clean depending on the condition using degreaser and dry them using an air compressor.

Warning

- Always wear protective eye wear when using the air compressor. Otherwise, degreaser or dirt particles blown off by the air compressor could get into the eyes.

3. Clean away the used packing tape as a plug.

A : Plug (packing tape)

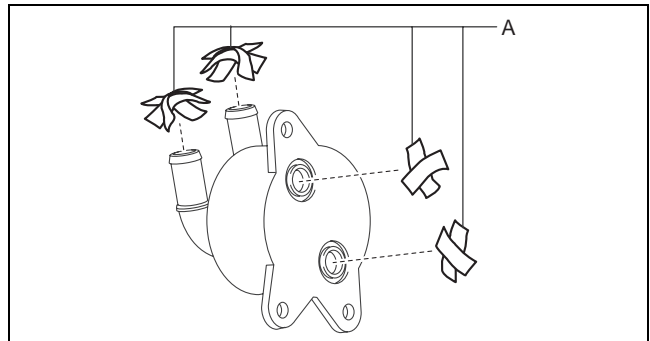

azzjw00001505

Oil Cooler Flushing (Water Passage)

1. Plug the position (water passage) shown in the figure with packing tape.

A : Plug (packing tape)

Caution

- If engine coolant or water penetrates the oil cooler (in oil passage), it could cause a malfunction. Therefore, when flushing the oil cooler (water passage), plug the position (oil passage) shown in the figure with packing tape.

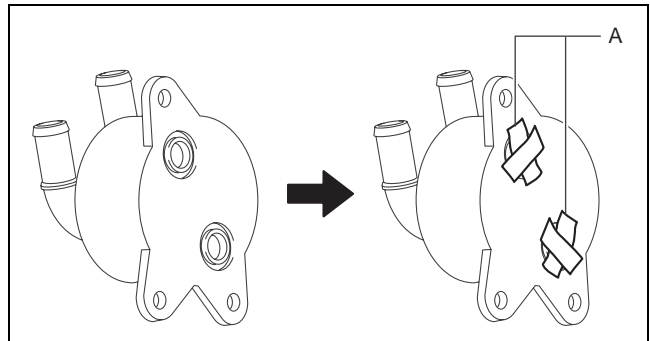

azzjw00001506

AUTOMATIC TRANSAXLE

2. Prepare a clean oil receptacle.

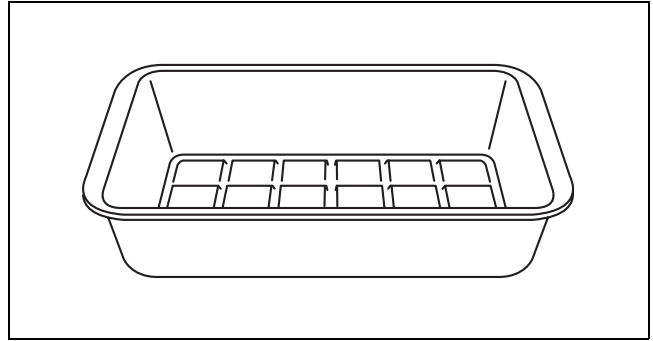

azzjw00001066

3. Add water to the oil cooler from the water passage shown in the figure.

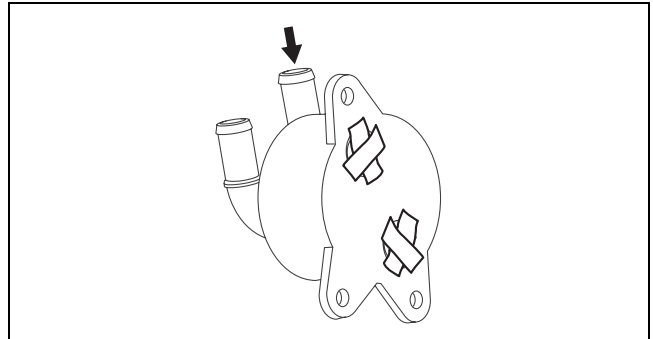

azzjw00001507

4. Blow compressed air into the water passage shown in the figure and drain the engine coolant and water in the oil cooler.

Warning

- Always wear protective eye wear when using the air compressor. Otherwise, engine coolant, water, or dirt particles blown off by the air compressor could get into the eyes.

Caution

- Perform the work at a position where the engine coolant and water in the oil cooler can be drained into a clean oil receptacle.
- To prevent damage to parts, always use an air compressor which is adjusted to the indicated pressure.

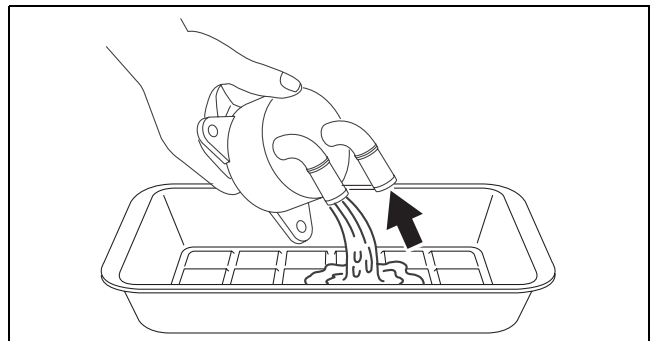

azzjw00001508

Compressed air pressure

150—200 kPa {1.53—2.03 kgf/cm², 21.8—29.0 psi}

5. Verify that none of the following foreign material is mixed in with the engine coolant and water drained from the oil cooler.
 - Rust or water stain due to deterioration of engine coolant
 - Engine oil
 - Fragments of cooling system parts (plastic, metal, or rubber fragments)
6. Dispose of the engine coolant and water in the oil receptacle and clean the oil receptacle.

AUTOMATIC TRANSAXLE

7. Perform Steps 3—6 three times.

- If foreign material remains even after the oil cooler is flushed repeatedly, replace the oil cooler with a new one and inspect the cooling system part.

Note

- For the cooling system part inspection, verify the Workshop Manual.

8. Clean away the used packing tape as a plug.

A : Plug (packing tape)

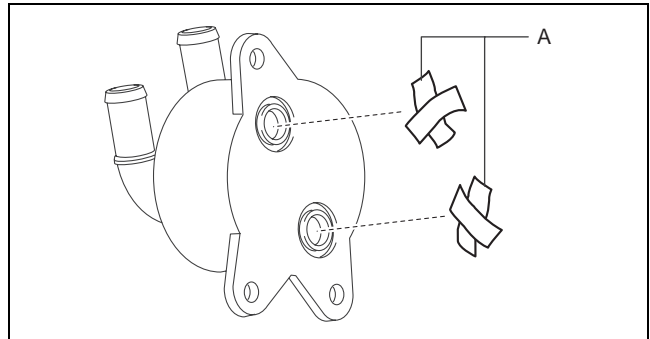

azzjw00001509

05-17

Oil Cooler Flushing (Oil Passage)

1. Plug to the position (water passage) shown in the figure with packing tape.

A : Plug (packing tape)

Caution

- If ATF penetrates the oil cooler (in water passage), it could cause a malfunction. Therefore, when flushing the oil cooler (oil passage), plug the position (water passage) shown in the figure with packing tape.

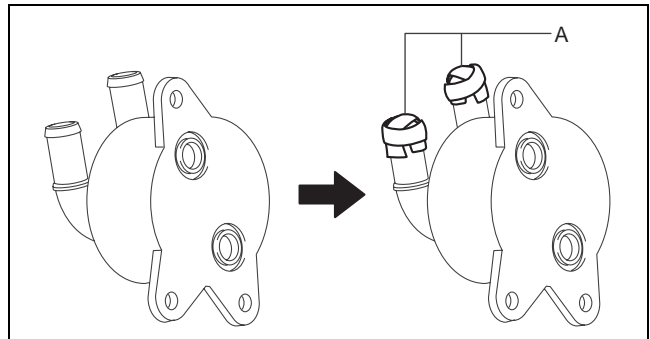

azzjw00001510

2. Prepare a clean oil receptacle.

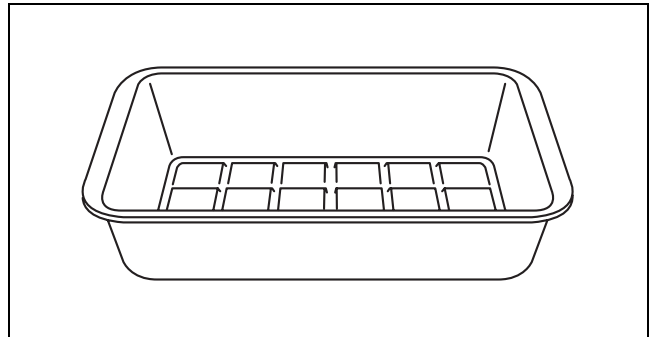

azzjw00001066

AUTOMATIC TRANSAXLE

3. Add new ATF (ATF FZ) to the oil cooler from the oil passage shown in the figure.

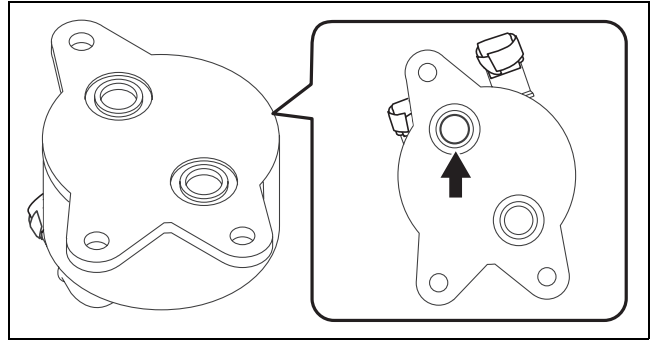

azzjiw00001511

4. Blow compressed air into the oil passage shown in the figure and drain the ATF in the oil cooler.

Warning

- Always wear protective eye wear when using the air compressor. Otherwise, ATF or dirt particles blown off by the air compressor could get into the eyes.

Caution

- Perform the work at a position where the ATF in the oil cooler can be drained into a clean oil receptacle.
- To prevent damage to parts, always use an air compressor which is adjusted to the indicated pressure.

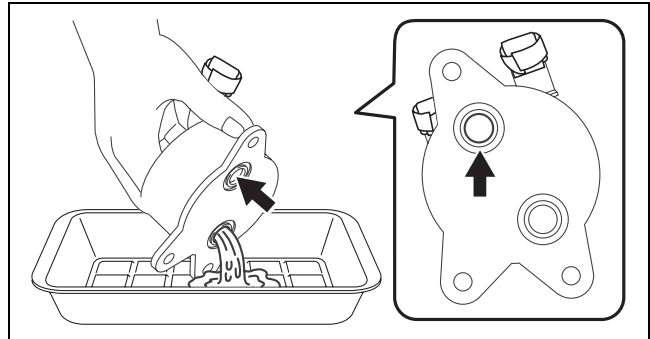

azzjiw00001512

Compressed air pressure

491—882 kPa {5.01—8.99 kgf/cm², 71.3—127.0 psi}

5. Verify that none of the following foreign material is mixed in with the ATF drained from the oil cooler.
 - Large metal fragments of ϕ 0.5 mm {0.02 in} or more that cannot pass through the oil strainer
 - Fibrous clutch or brake facing
 6. Dispose of the ATF in the oil receptacle and clean the oil receptacle.
 7. Perform Steps 3—6 three times.
 - If foreign material such as metal fragments or facing remain even after the oil cooler is flushed repeatedly, replace the oil cooler with a new one.
 8. Clean away the used packing tape used as the plug.
- A : Plug (packing tape)

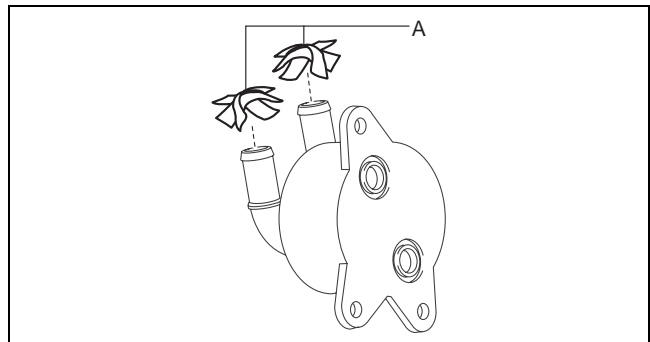

azzjiw00001513

AUTOMATIC TRANSAXLE

VISUAL INSPECTION OF PARTS

id051700661700

1. Visually inspect the parts according to the following table and replace a malfunctioning part with a new one.

Note

- Check the color depending on the condition to specify the malfunctioning part.

Part name (mechanism name)	Inspection item
Gear	Missing teeth or tooth loss
	Peeling on tooth surface
	Other damage (cracks, wear, impact, deformation, burning or seizure)
Tapered roller bearing	Peeling on sliding surface
	Cage deformation
	Discoloration due to burning (temper color)
	Other damage (cracks, wear, impact, deformation, burning or seizure)
Thrust needle bearing	Peeling on sliding surface
	Discoloration due to burning (temper color)
	Other damage (cracks, wear, impact, deformation, burning or seizure)
Radial needle bearing	Peeling on sliding surface
	Cage deformation
	Discoloration due to burning (temper color)
	Other damage (cracks, wear, impact, deformation, burning or seizure)
Clutch (brake) drive plate	Facing peeling
	Discoloration due to burning (temper color)
	Other damage (cracks, wear, impact, deformation, burning or seizure)
Clutch (brake) piston and seal plate	Lip (rubber) tear or wear
	Other damage (cracks, impact, deformation)
Clutch (brake) springs and retainer component	Spring removal
	Spring deformation (significant attitude)
	Retainer deformation
	Other damage (cracks, wear, impact)
Parts other than the above	External appearance damage (cracks, wear, impact, deformation, burning or seizure)

05-17

AUTOMATIC TRANSAXLE

2. Verify that there is no bushing adhesion trace or significant sliding trace on the following bushing sliding part.

- Torque converter
 - If there is a malfunction, replace the torque converter with a new one.

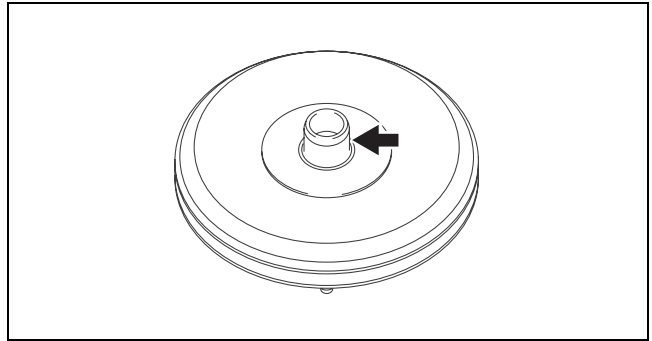

azzjw00001514

- Turbine shaft
 - If there is a malfunction, replace the turbine shaft with a new one.

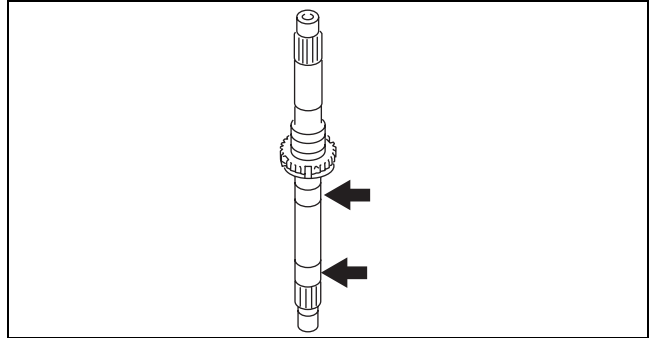

azzjw00001515

- High clutch hub
 - If there is a malfunction, replace the high clutch hub with a new one.

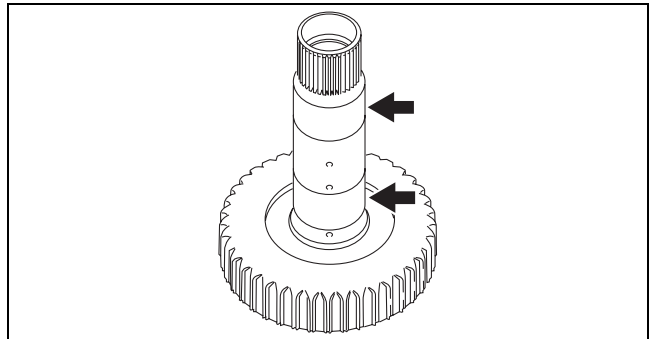

azzjw00001516

- End cover
 - If there is a malfunction, replace the end cover with a new one.

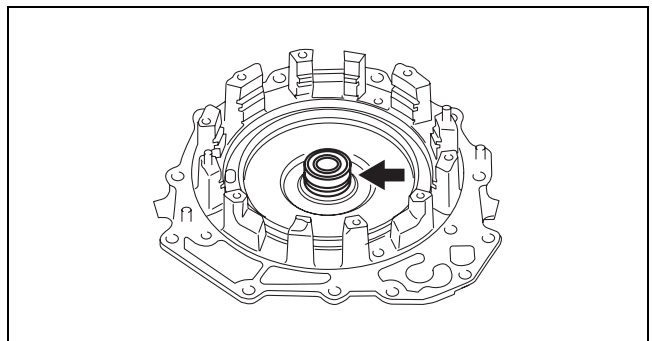

azzjw00001517

AUTOMATIC TRANSAXLE

3. Verify that there is no significant sliding trace on the following journal part.
- Ring gear and differential

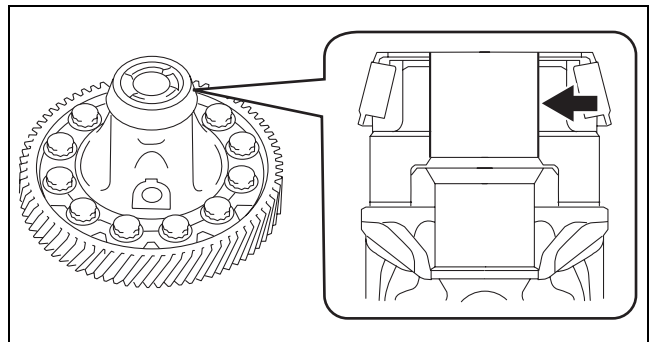

azzjjw00001518

- If there is a malfunction, disassemble the ring gear and differential and replace the differential gear case with a new one. (See 05-17-121 RING GEAR AND DIFFERENTIAL DISASSEMBLY.) (See 05-17-266 RING GEAR AND DIFFERENTIAL ASSEMBLY.)

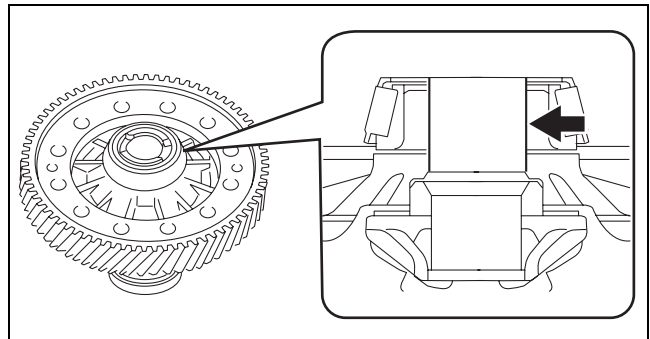

azzjjw00001521

- Drive shaft (LH)
 - If there is a malfunction, disassemble the drive shaft (LH) and replace the outer ring with a new one.

Note

- For the drive shaft disassembly/assembly procedure, verify the Workshop Manual.

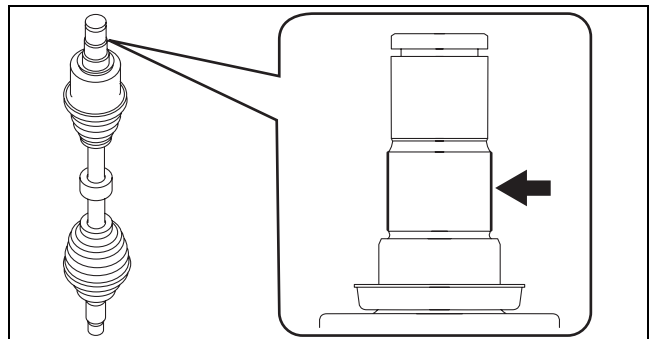

azzjjw00001519

- Joint shaft
 - If there is a malfunction, replace the joint shaft with a new one.

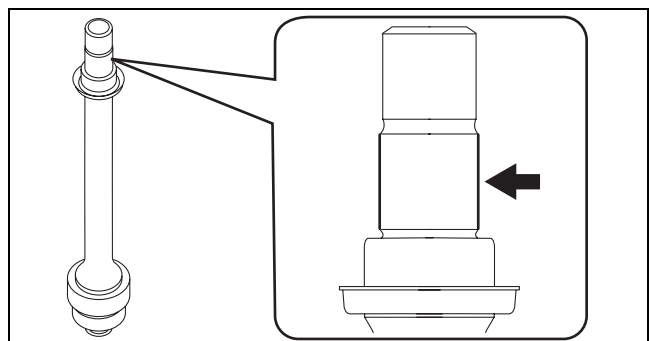

azzjjw00001520

AUTOMATIC TRANSAXLE

TORQUE CONVERTER INSPECTION

id051700661800

Caution

- For the torque converter inspection, only an inspection for burning or seizure of the TCC clutch can be performed. For other malfunctions, on-vehicle inspection is required.

1. Assemble the turbine shaft to the torque converter.

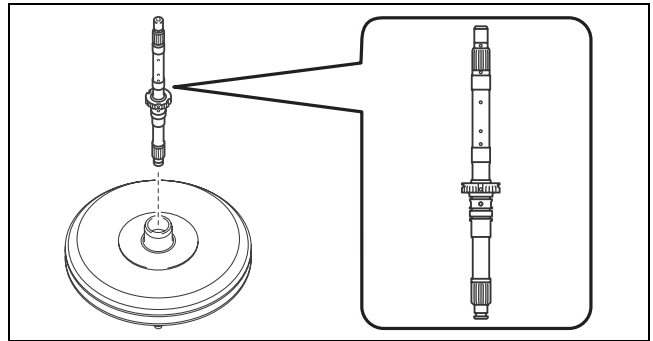

azzjiw00001069

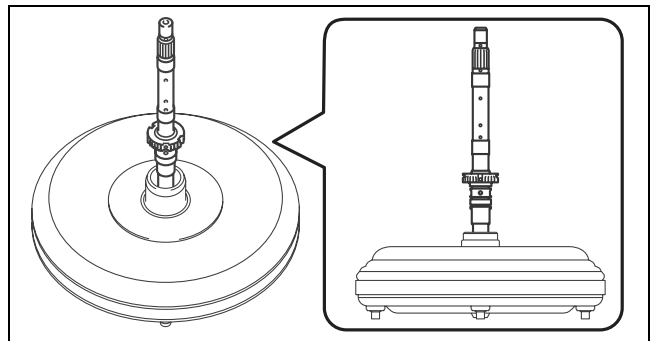

azzjiw00001070

2. With the torque converter secured by hand, rotate the turbine shaft.

A : Secure by hand

Note

- When rotating the turbine shaft, a little force is required depending on the amount of ATF in the torque converter.
- If the turbine shaft cannot be rotated, burning or seizure of the TCC clutch can be considered, therefore replace the torque converter with a new one.

3. Remove the turbine shaft.

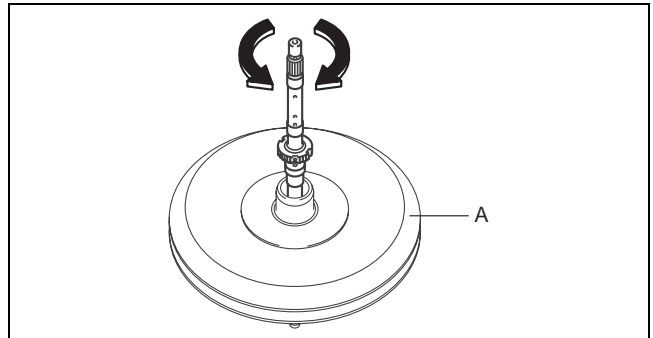

azzjiw00001071

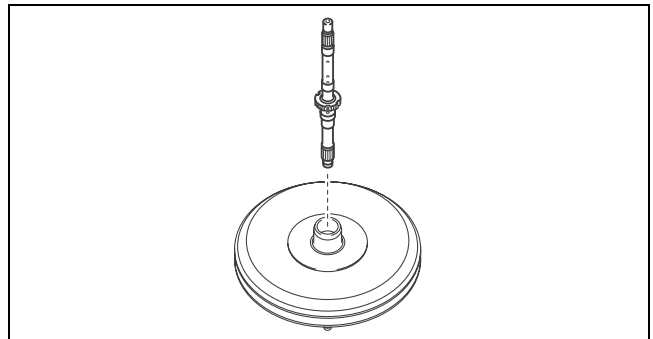

azzjiw00001072

AUTOMATIC TRANSAXLE

THRUST NEEDLE BEARING INSPECTION

id051700661900

1. Point the flat surface of the thrust needle bearing downward and place it on the surface plate.

A : Surface plate

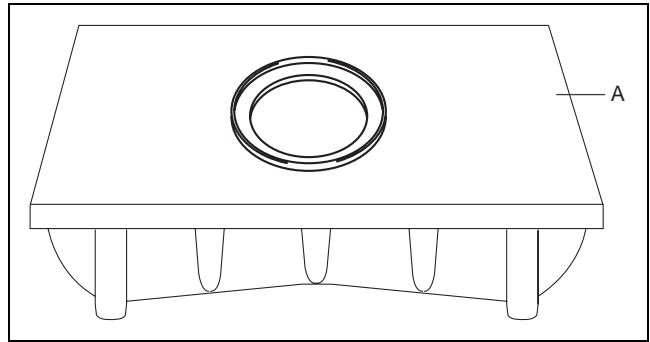

2. With a load applied by hand to the thrust needle bearing, rotate the thrust needle bearing and verify that there is no malfunction (rotation sticking).

- If there is a malfunction, replace the thrust needle bearing with a new one.

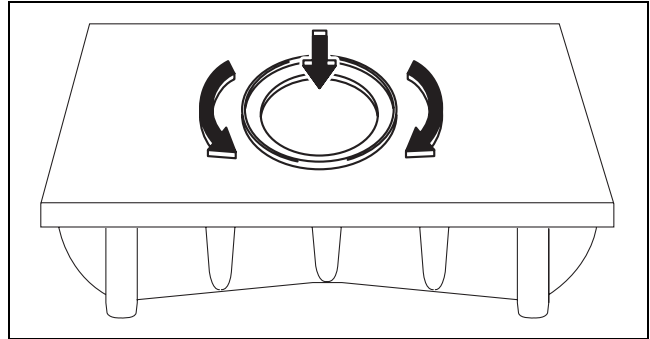

FRONT PLANETARY GEAR INSPECTION

id051700662000

Radial Needle Bearing Inspection (In Pinion Gear)

1. Place the front planetary gear on a workbench as shown in the figure.

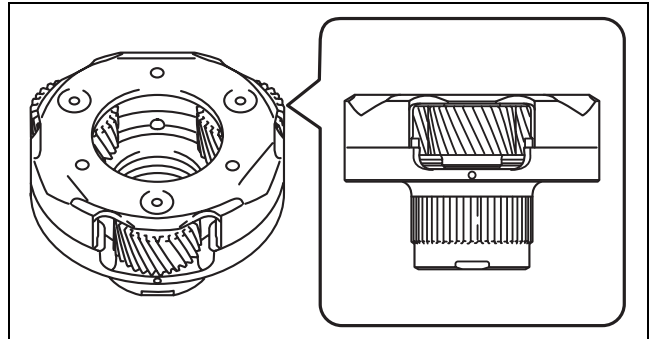

2. Rotate the pinion gears by hand and verify that there is no malfunction in the radial needle bearing in the pinion gear (rotation sticking).

Caution

- Verify for all the pinion gears.
- If there is a malfunction, replace the front planetary gear with a new one.

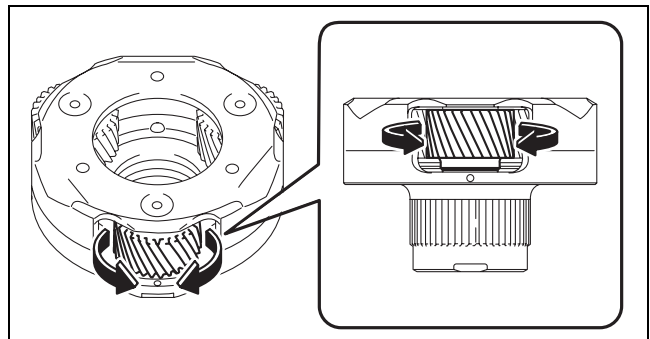

azzijw00001277

AUTOMATIC TRANSAXLE

Thrust Needle Bearing Inspection

1. Place the front planetary gear on a workbench as shown in the figure.

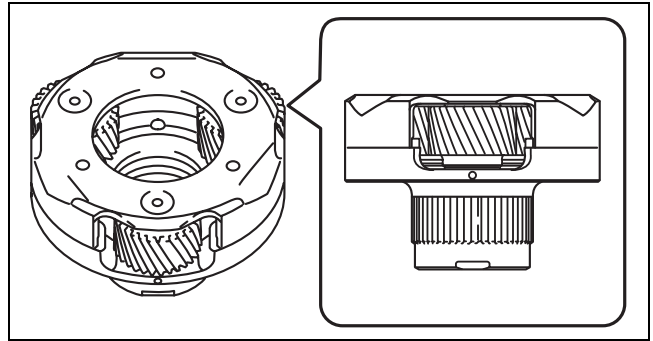

azzjw00001259

2. Assemble the front sun gear to the front planetary gear.

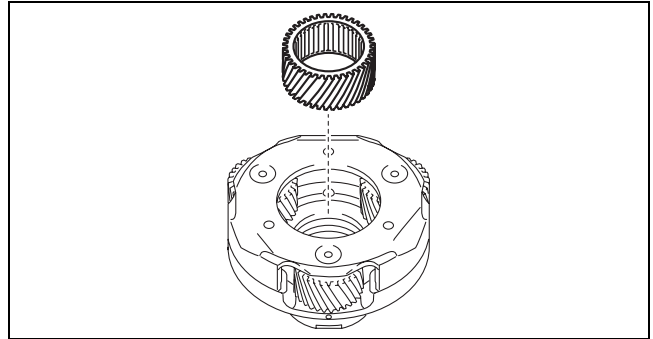

azzjw00001261

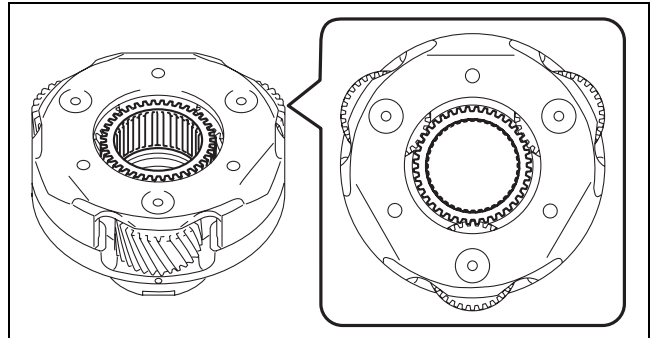

azzjw00001262

3. With a load applied by hand to the front sun gear, rotate the front sun gear and verify that there is no malfunction in the thrust needle bearing (rotation sticking).

- If there is a malfunction, replace the front planetary gear with a new one.

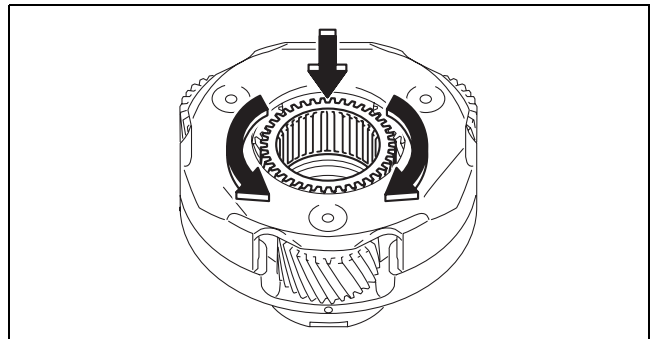

azzjw00001263

4. Remove the front sun gear.

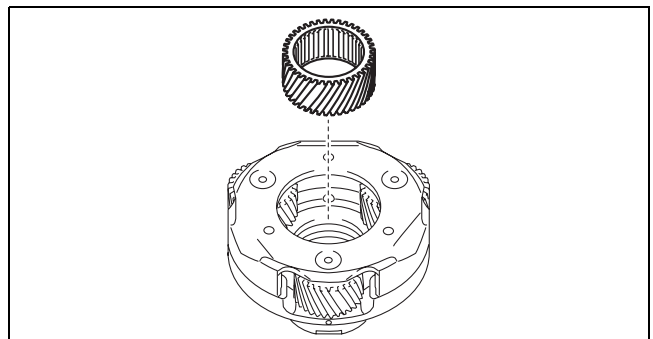

azzjw00001261

Pinion Washer Inspection

Pinion washer visual inspection

1. Visually verify that all of the following washers are between the pinion gear and planetary carrier for one pinion gear.

Caution

- **Verify for all the pinion gears.**

- Copper washer (outer side): 2
- Iron washer (inner side): 2

A : Copper washer (outer side)

B : Iron washer (inner side)

- Even if one of the washers is damaged, replace the front planetary gear with a new one.

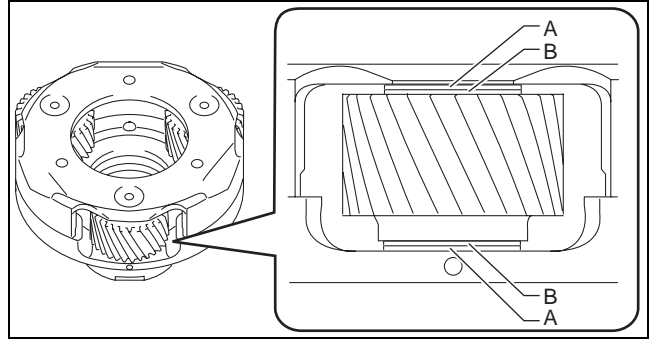

azzjw00001522

Pinion washer wear inspection

1. Place the front planetary gear on a workbench as shown in the figure.

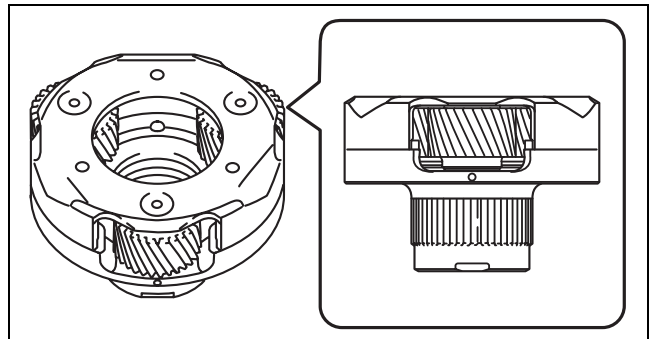

azzjw00001259

2. Measure the gap between the pinion washer and planetary carrier.

Caution

- **Measure for all the pinion gears.**

Note

- Recommended measuring instrument:
Thickness gauge

Maximum:
0.879 mm {0.0346 in}

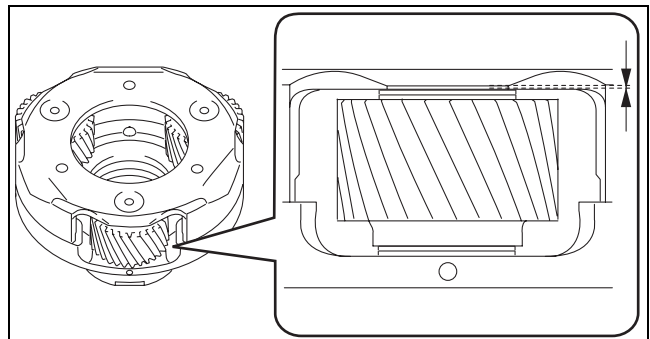

azzjw00001523

- If it is more than the maximum specification, replace the front planetary gear with a new one.

AUTOMATIC TRANSAXLE

REAR PLANETARY GEAR INSPECTION

id051700662100

Radial Needle Bearing Inspection (In Pinion Gear)

1. Place the rear planetary gear with the front internal gear side pointing upward on a workbench.

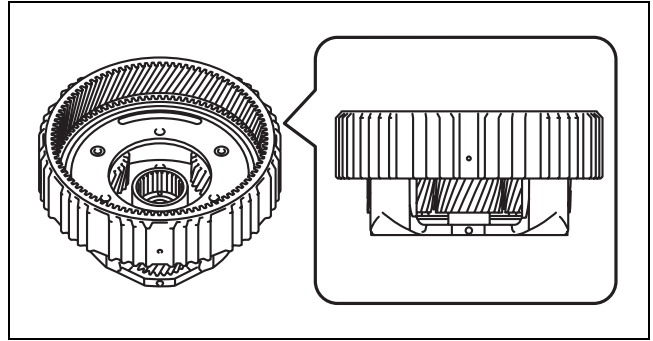

azzijw00001265

2. Rotate the pinion gears by hand and verify that there is no malfunction in the radial needle bearing in the pinion gear (rotation sticking).

Caution

- Verify for all the pinion gears.
- If there is a malfunction, disassemble the rear planetary gear and replace the rear planetary carrier with a new one.
(See 05-17-117 REAR PLANETARY GEAR DISASSEMBLY.)
(See 05-17-259 REAR PLANETARY GEAR ASSEMBLY.)

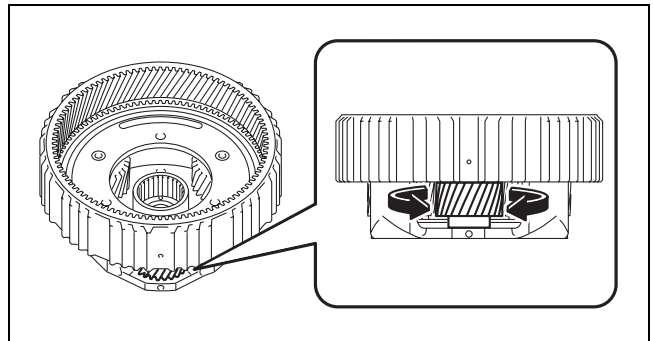

azzijw00001278

Thrust Needle Bearing Inspection

1. Place the rear planetary gear with the front internal gear side pointing upward on a workbench.

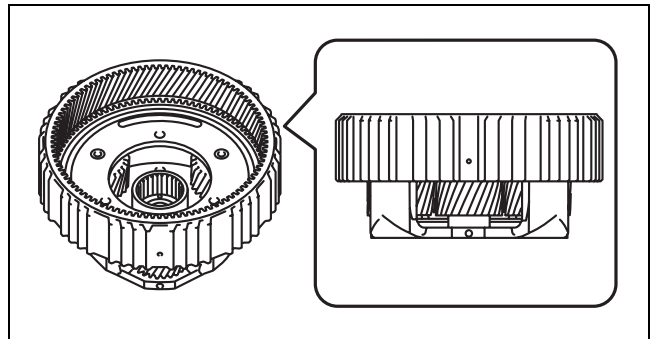

azzijw00001265

AUTOMATIC TRANSAXLE

2. Assemble the rear sun gear to the rear planetary gear.

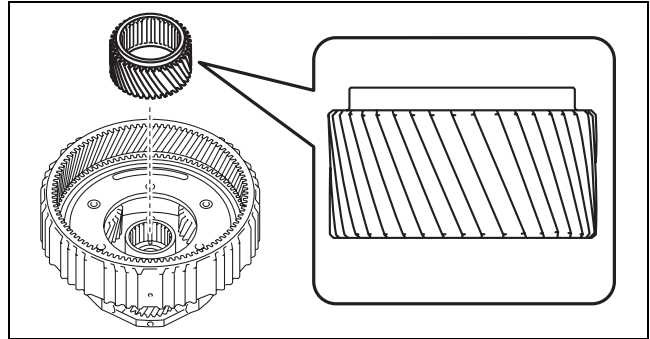

azzjjw00001267

05-17

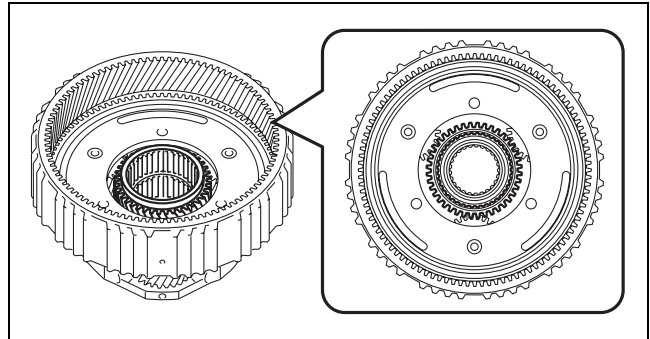

azzjjw00001268

3. With a load applied by hand to the rear sun gear, rotate the rear sun gear and verify that there is no malfunction in the thrust needle bearing (rotation sticking).

- If there is a malfunction, disassemble the rear planetary gear and replace the rear planetary carrier with a new one. (See 05-17-117 REAR PLANETARY GEAR DISASSEMBLY.) (See 05-17-259 REAR PLANETARY GEAR ASSEMBLY.)

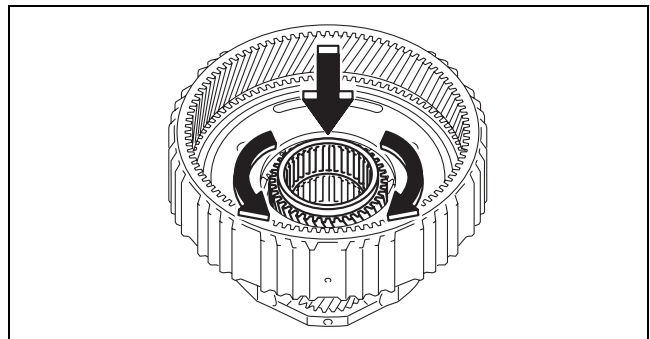

azzjjw00001269

4. Remove the rear sun gear.

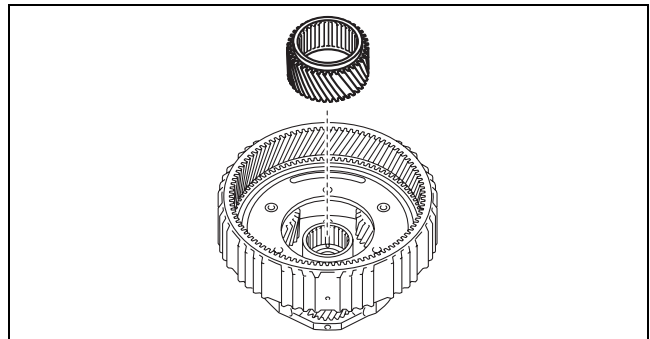

azzjjw00001270

AUTOMATIC TRANSAXLE

Pinion Washer Inspection

Pinion washer visual inspection

1. Visually verify that all of the following washers are between the pinion gear and planetary carrier for one pinion gear.

Caution

- Verify for all the pinion gears.

- Copper washer (outer side): 2
- Iron washer (inner side): 2

A : Copper washer (outer side)

B : Iron washer (inner side)

- Even if one of the washers is damaged, disassemble the rear planetary gear and replace the rear planetary carrier with a new one.
(See 05-17-117 REAR PLANETARY GEAR DISASSEMBLY.)
(See 05-17-259 REAR PLANETARY GEAR ASSEMBLY.)

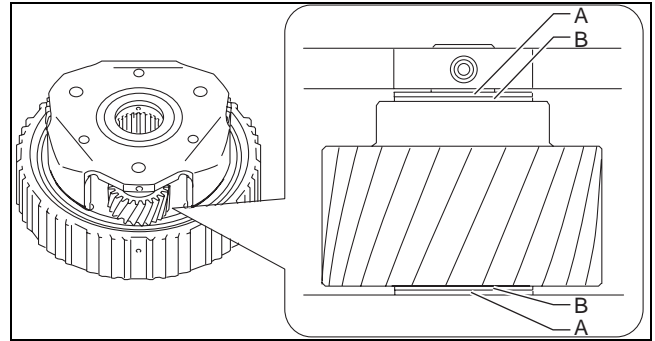

azzjiw00001524

Pinion washer wear inspection

1. Place the rear planetary gear with the front internal gear side pointing downward on a workbench.

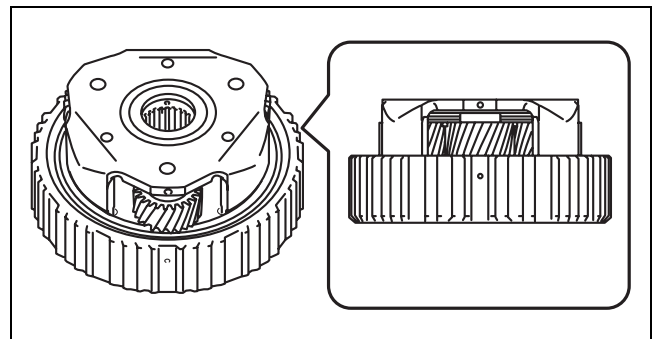

azzjiw00001271

2. Measure the gap between the pinion washer and planetary carrier.

Caution

- Measure for all the pinion gears.

Note

- Recommended measuring instrument:
Thickness gauge

Maximum:

0.879 mm {0.0346 in}

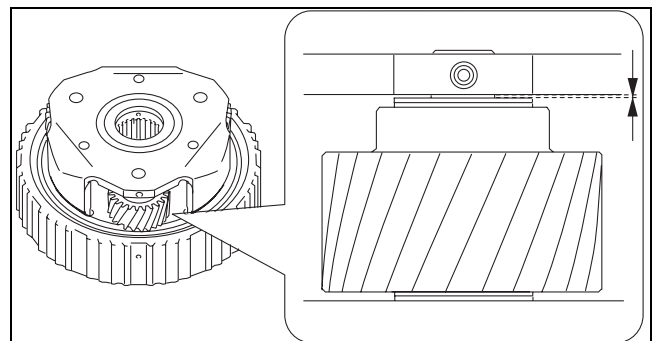

azzjiw00001525

- If it is more than the maximum specification, disassemble the rear planetary gear and replace the rear planetary carrier with a new one.
(See 05-17-117 REAR PLANETARY GEAR DISASSEMBLY.)
(See 05-17-259 REAR PLANETARY GEAR ASSEMBLY.)

REDUCTION PLANETARY GEAR INSPECTION

id051700662200

Radial Needle Bearing Inspection (In Pinion Gear)

1. Place the reduction planetary gear with the rear internal gear side pointing downward on a workbench.

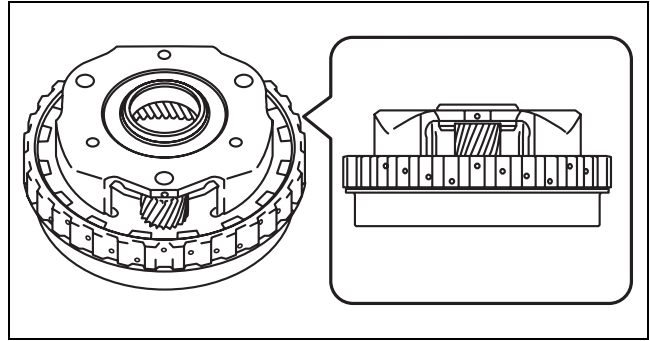

azzjjw00001273

2. Rotate the pinion gears by hand and verify that there is no malfunction in the radial needle bearing in the pinion gear (rotation sticking).

Caution

- Verify for all the pinion gears.
- If there is a malfunction, disassemble the reduction planetary gear and replace the reduction planetary carrier with a new one. (See 05-17-136 REDUCTION PLANETARY GEAR DISASSEMBLY.) (See 05-17-261 REDUCTION PLANETARY GEAR ASSEMBLY.)

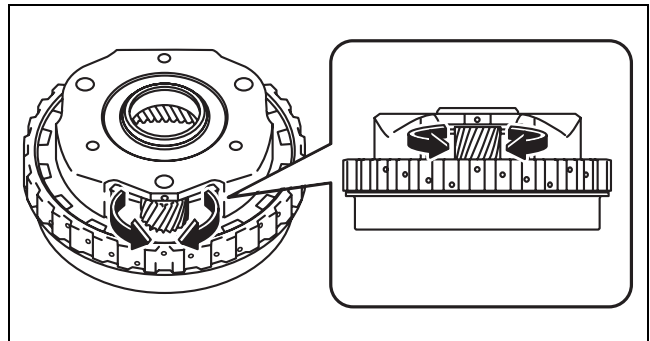

azzjjw00001274

Pinion Washer Inspection

Pinion washer visual inspection

1. Visually verify that all of the following washers are between the pinion gear and planetary carrier for one pinion gear.

Caution

- Verify for all the pinion gears.

— Copper washer: 2

A : Copper washer

- Even if one of the washers are damaged, disassemble the reduction planetary gear and replace the reduction planetary carrier with a new one. (See 05-17-136 REDUCTION PLANETARY GEAR DISASSEMBLY.) (See 05-17-261 REDUCTION PLANETARY GEAR ASSEMBLY.)

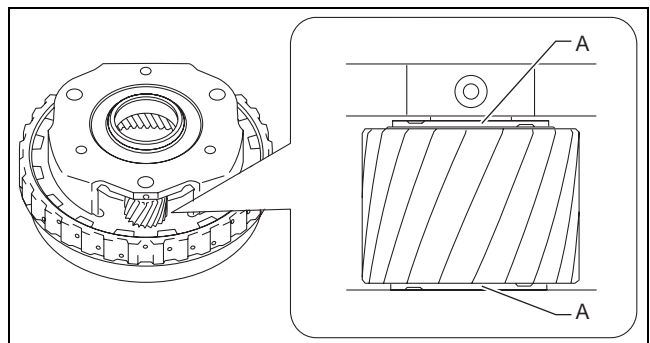

azzjjw00001526

AUTOMATIC TRANSAXLE

Pinion washer wear inspection

1. Place the reduction planetary gear with the rear internal gear side pointing downward on a workbench.

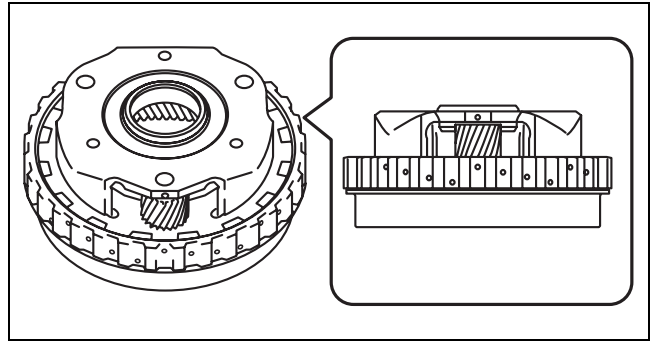

azzjiw00001273

2. Measure the gap between the pinion washer and planetary carrier.

Caution

- Measure for all the pinion gears.

Note

- Recommended measuring instrument:
Thickness gauge

Maximum:

0.820 mm {0.0322 in}

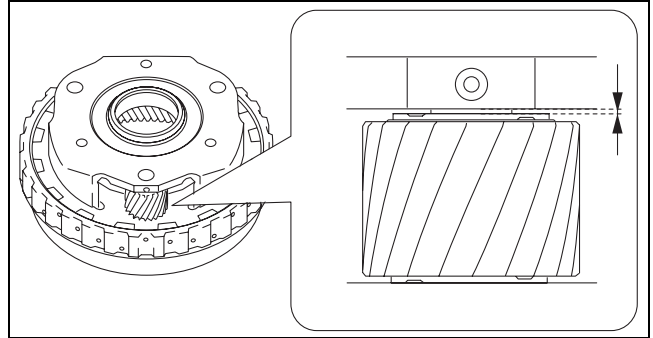

azzjiw00001527

- If it is more than the maximum specification, disassemble the reduction planetary gear and replace the reduction planetary carrier with a new one.
(See 05-17-136 REDUCTION PLANETARY GEAR DISASSEMBLY.)
(See 05-17-261 REDUCTION PLANETARY GEAR ASSEMBLY.)

Bush Inner Diameter Inspection

1. Measure the inner diameter of the bush shown in the figure.

Note

- When measuring, measure near the center of the bush avoiding the oil groove, and then calculate the average value of the X and Y directions as shown in the figure.
- Recommended measuring instrument:
Cylinder gauge or caliper gauge

Maximum:

35.095 mm {1.3816 in}

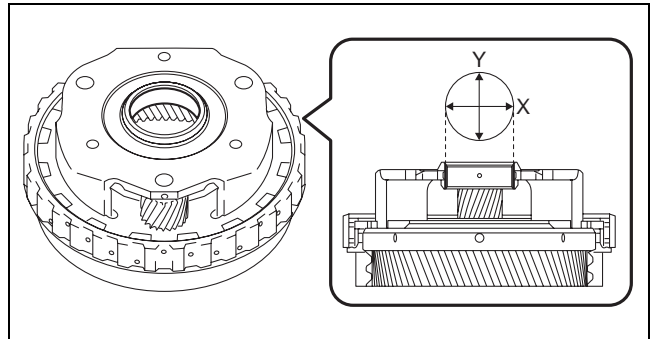

azzjiw00001276

- If it is more than the maximum specification, disassemble the reduction planetary gear and replace the reduction planetary carrier with a new one.
(See 05-17-136 REDUCTION PLANETARY GEAR DISASSEMBLY.)
(See 05-17-261 REDUCTION PLANETARY GEAR ASSEMBLY.)

AUTOMATIC TRANSAXLE

SECONDARY GEAR AND OUTPUT GEAR INSPECTION

id051700662300

Taper Roller Bearing Inspection

1. Place the secondary gear and output gear with the output gear side pointing upward on a workbench.

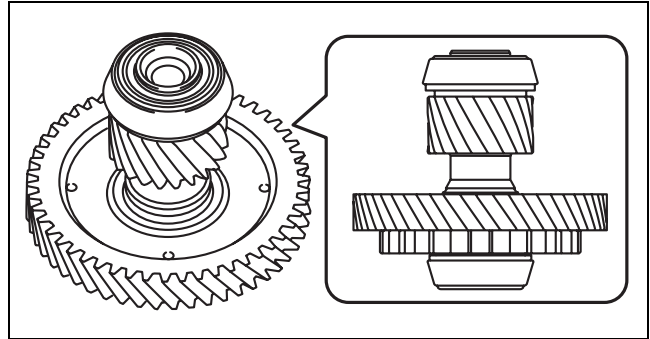

azzjjw00001279

2. Assemble the bearing race to the secondary gear and output gear.

Note

- Bearing race size: Outer diameter approx. 75 mm {3.0 in}

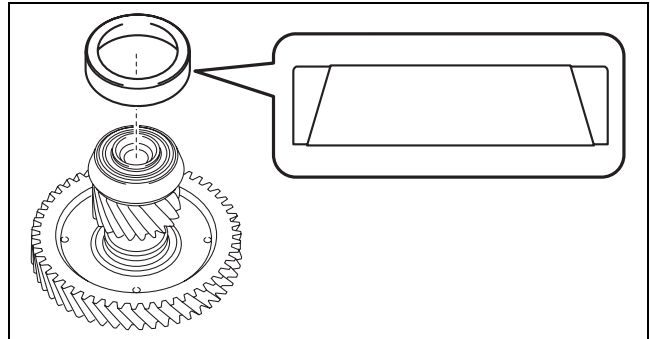

azzjjw00001280

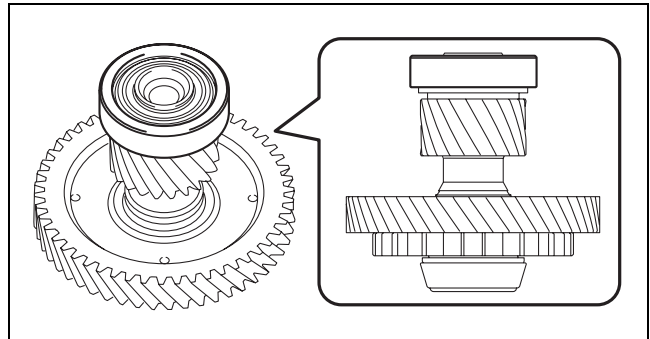

azzjjw00001281

3. With a load applied by hand to the bearing race, rotate the bearing race and verify that there is no malfunction in the taper roller bearing (rotation sticking).

- If there is a malfunction, disassemble the secondary gear and output gear and replace the taper roller bearing with a new one. (See 05-17-119 SECONDARY GEAR AND OUTPUT GEAR DISASSEMBLY.) (See 05-17-263 SECONDARY GEAR AND OUTPUT GEAR ASSEMBLY.)

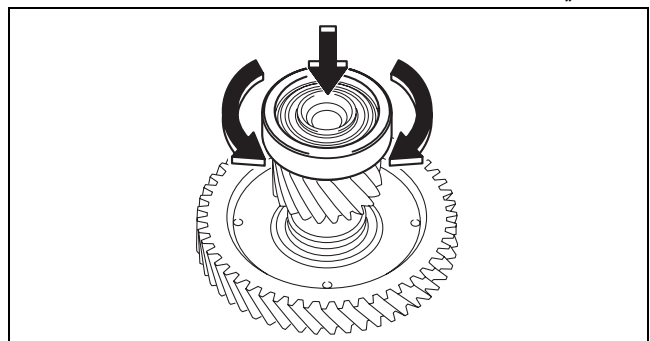

azzjjw00001282

4. Remove the bearing race.

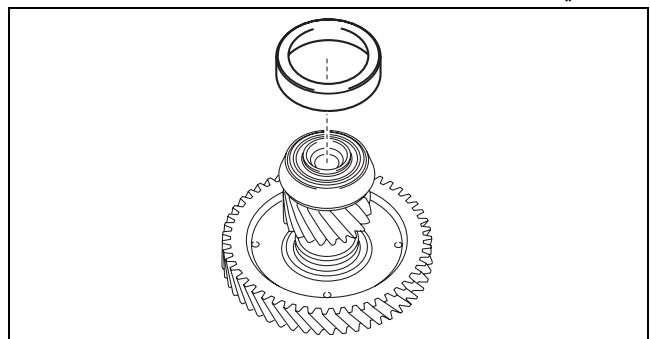

azzjjw00001283

05-17

AUTOMATIC TRANSAXLE

5. Place the secondary gear and output gear with the output gear side pointing downward on a workbench.

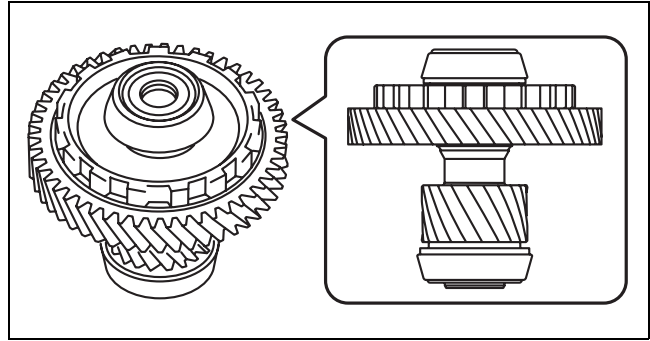

azzjw00001284

6. Assemble the bearing race to the secondary gear and output gear.

Note

- Bearing race size: Outer diameter approx. 70 mm {2.8 in}

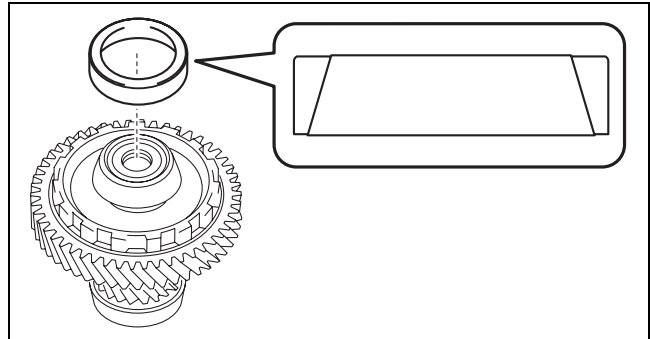

azzjw00001285

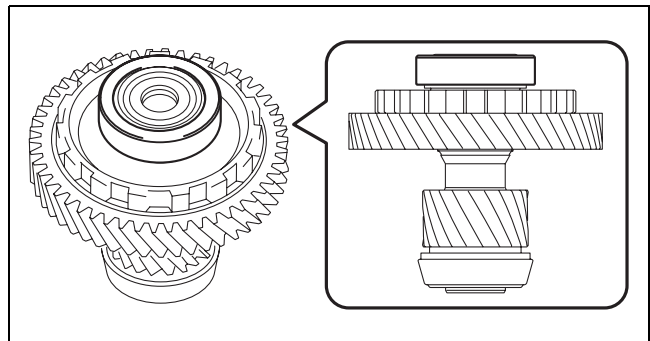

azzjw00001286

7. With a load applied by hand to the bearing race, rotate the bearing race and verify that there is no malfunction in the taper roller bearing (rotation sticking).

- If there is a malfunction, disassemble the secondary gear and output gear and replace the taper roller bearing with a new one. (See 05-17-119 SECONDARY GEAR AND OUTPUT GEAR DISASSEMBLY.) (See 05-17-263 SECONDARY GEAR AND OUTPUT GEAR ASSEMBLY.)

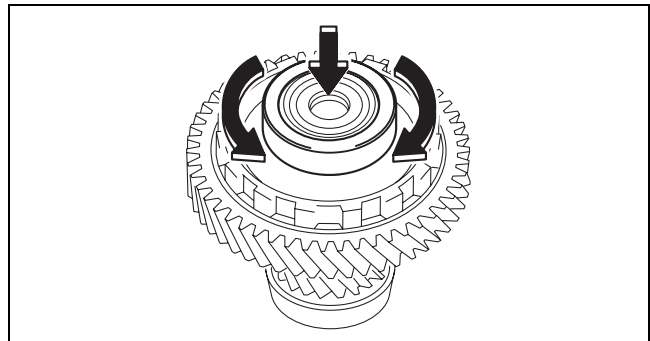

azzjw00001287

8. Remove the bearing race.

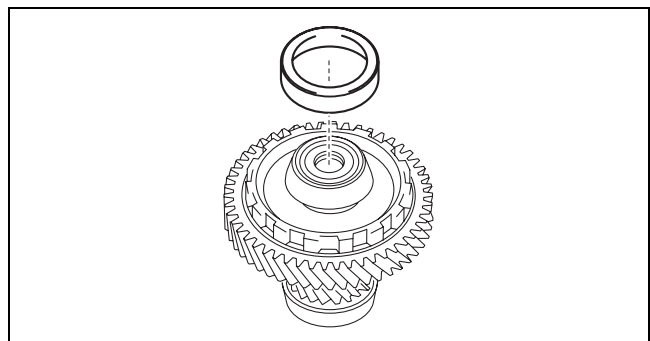

azzjw00001288

RING GEAR AND DIFFERENTIAL INSPECTION

id051700662400

Taper Roller Bearing Inspection

1. Place the ring gear and differential with the ring gear side pointing upward on a workbench.

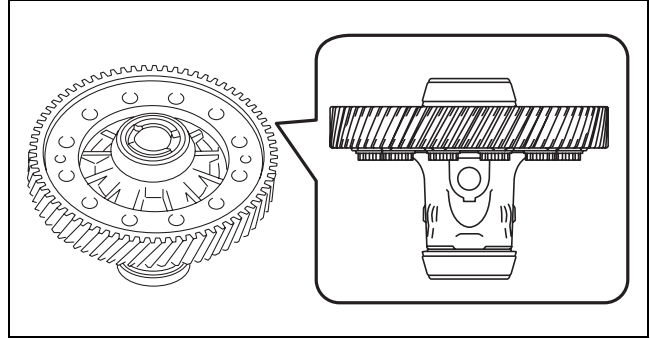

azzjjw00001289

2. Assemble the bearing race to the ring gear and differential.

Note

- Bearing race size: Outer diameter approx. 80 mm {3.1 in}

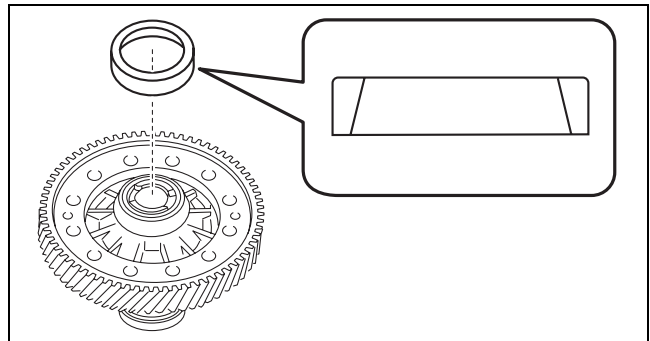

azzjjw00001290

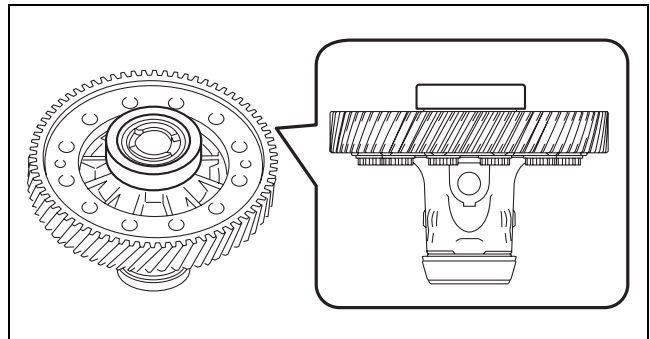

azzjjw00001291

3. With a load applied by hand to the bearing race, rotate the bearing race and verify that there is no malfunction in the taper roller bearing (rotation sticking).

- If there is a malfunction, disassemble the ring gear and differential and replace the taper roller bearing with a new one. (See 05-17-121 RING GEAR AND DIFFERENTIAL DISASSEMBLY.) (See 05-17-266 RING GEAR AND DIFFERENTIAL ASSEMBLY.)

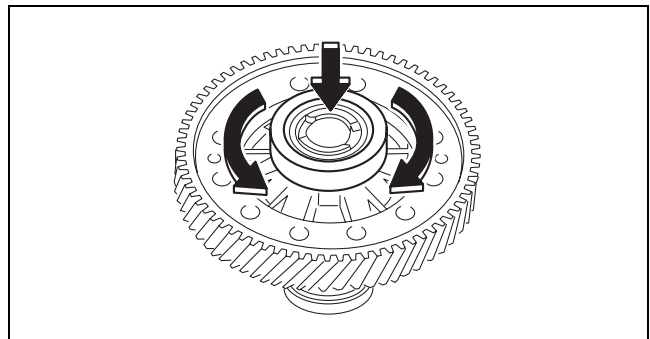

azzjjw00001292

05-17

AUTOMATIC TRANSAXLE

4. Remove the bearing race.

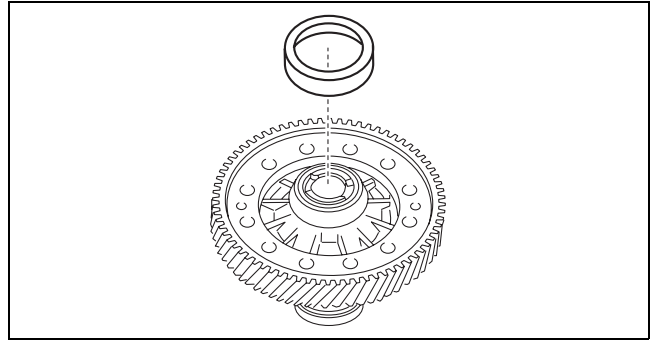

azzjw00001293

5. Place the ring gear and differential with the ring gear side pointing downward on a workbench.

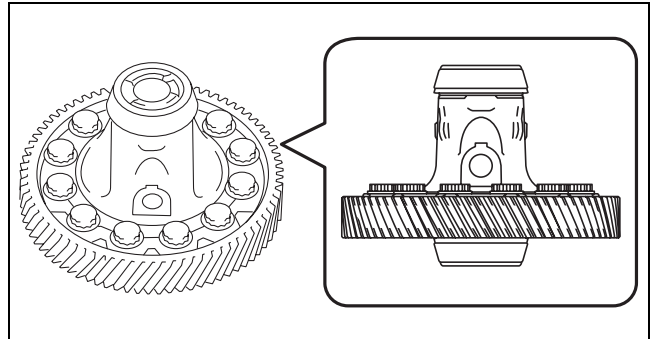

azzjw00001294

6. Assemble the bearing race to the ring gear and differential.

Note

- Bearing race size: Outer diameter approx. 80 mm {3.1 in}

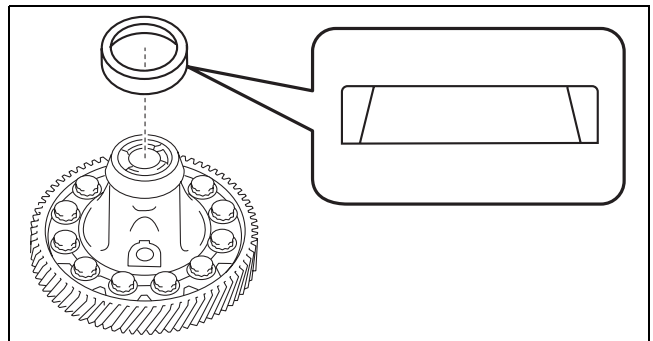

azzjw00001295

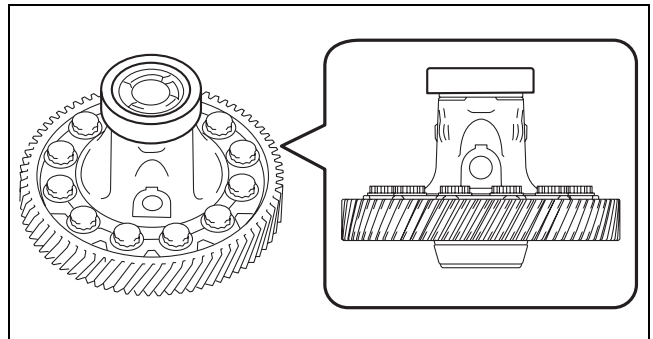

azzjw00001296

7. With a load applied by hand to the bearing race, rotate the bearing race and verify that there is no malfunction in the taper roller bearing (rotation sticking).

- If there is a malfunction, disassemble the ring gear and differential and replace the taper roller bearing with a new one. (See 05-17-121 RING GEAR AND DIFFERENTIAL DISASSEMBLY.) (See 05-17-266 RING GEAR AND DIFFERENTIAL ASSEMBLY.)

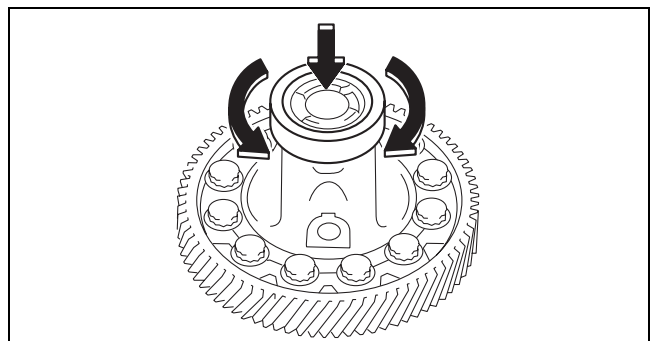

azzjw00001297

8. Remove the bearing race.

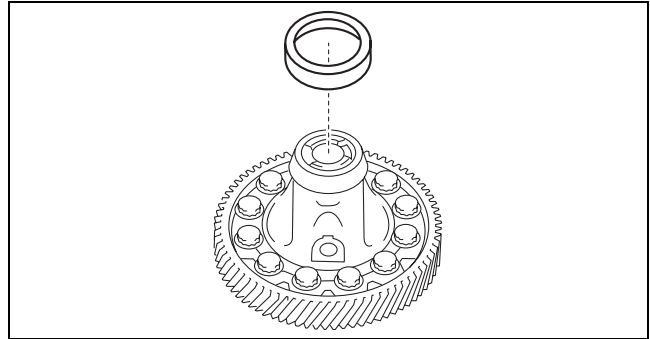

azzjw00001298

Differential Journal Inspection

1. Measure the inner diameter of the journal (front side) shown in the figure.

Note

- When measuring, measure near the center of the journal avoiding the oil groove, and then calculate the average value of the X and Y directions as shown in the figure.
- Recommended measuring instrument: Cylinder gauge or caliper gauge

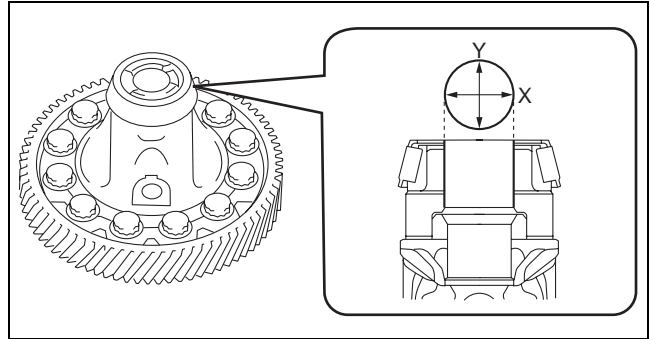

azzjw00001299

Maximum:
30.046 mm {1.1829 in}

- If it is more than the maximum specification, disassemble the ring gear and differential and replace the differential gear case with a new one.
(See 05-17-121 RING GEAR AND DIFFERENTIAL DISASSEMBLY.)
(See 05-17-266 RING GEAR AND DIFFERENTIAL ASSEMBLY.)

2. Measure the inner diameter of the journal (rear side) shown in the figure.

Note

- When measuring, measure near the center of the journal avoiding the oil groove, and then calculate the average value of the X and Y directions as shown in the figure.
- Recommended measuring instrument: Cylinder gauge or caliper gauge

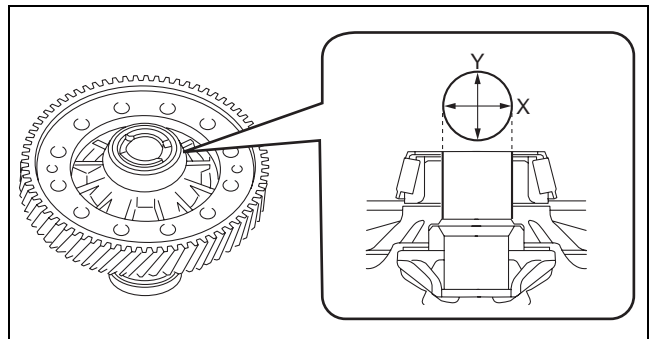

azzjw00001300

Maximum:
30.046 mm {1.1829 in}

- If it is more than the maximum specification, disassemble the ring gear and differential and replace the differential gear case with a new one.
(See 05-17-121 RING GEAR AND DIFFERENTIAL DISASSEMBLY.)
(See 05-17-266 RING GEAR AND DIFFERENTIAL ASSEMBLY.)

Differential Backlash Inspection

1. Perform the following the inspection and measurement/adjustment in the order and replace a malfunctioning part with a new one.

- (1) Drive shaft journal inspection (See 05-17-168 DRIVE SHAFT JOURNAL INSPECTION.)
- (2) Differential backlash measurement/adjustment (See 05-17-303 DIFFERENTIAL BACKLASH MEASUREMENT/ADJUSTMENT.)

AUTOMATIC TRANSAXLE

DRIVE SHAFT JOURNAL INSPECTION

id051700665500

1. Remove the drive shaft (LH) from the vehicle.

Note

- For the drive shaft (LH) removal procedure from the vehicle, verify the Workshop Manual.

2. Measure the outer diameter of the drive shaft (LH) journal.

Note

- When measuring, measure near the center of the journal, and then calculate the average value of the X and Y directions as shown in the figure.
- Recommended measuring instrument: Micrometer

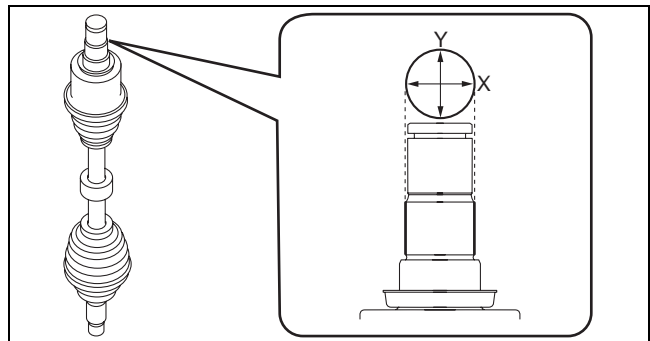

azzjw00001301

Minimum:

29.959 mm {1.1795 in}

- If it is less than the minimum specification, disassemble the drive shaft (LH) and replace the outer ring with a new one.

Note

- For the drive shaft disassembly/assembly procedure, verify the Workshop Manual.

3. Measure the outer diameter of the joint shaft journal.

Note

- When measuring, measure near the center of the journal, and then calculate the average value of the X and Y directions as shown in the figure.
- Recommended measuring instrument: Micrometer

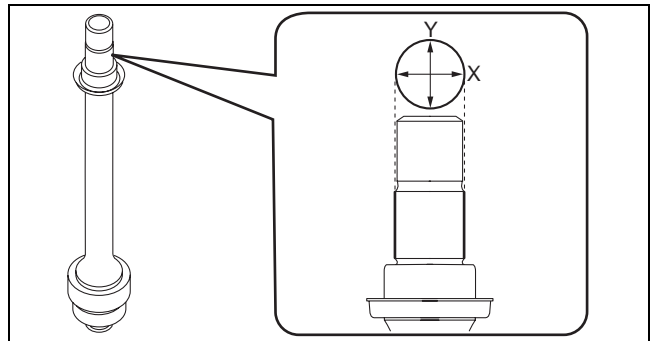

azzjw00001302

Minimum:

29.944 mm {1.1789 in}

- If it is less than the minimum specification, replace the joint shaft with a new one.

AUTOMATIC TRANSAXLE

LOW CLUTCH INSPECTION

id051700662500

Drive Plate Inspection

1. Measure the thickness of the drive plate in four locations (each separated by 90°) and calculate the average value.

Caution

- When measuring the thickness of the drive plate, measure the thickness including the facing.
- Measure the thickness of all the drive plates.

Note

- Drive plate size: Outer diameter approx. 159.1 mm {6.264 in}
- Recommended measuring instrument: Micrometer

Minimum:

1.475 mm {0.05808 in}

- If it is less than the minimum specification, replace the drive plate with a new one.

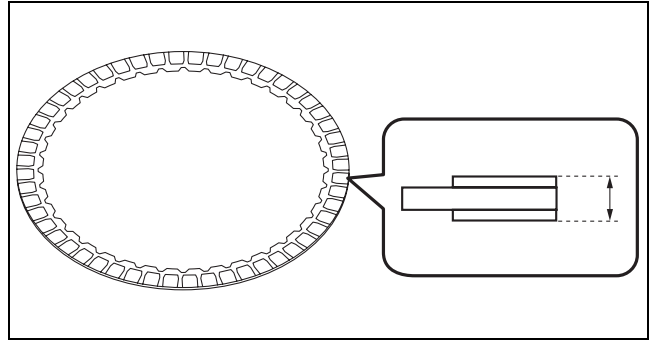

azzjjw00001312

05-17

HIGH CLUTCH INSPECTION

id051700662600

Drive Plate Inspection

1. Measure the thickness of the drive plate in four locations (each separated by 90°) and calculate the average value.

Caution

- When measuring the thickness of the drive plate, measure the thickness including the facing.
- Measure the thickness of all the drive plates.

Note

- Drive plate size: Outer diameter approx. 116.8 mm {4.598 in}
- Recommended measuring instrument: Micrometer

Minimum:

1.375 mm {0.05414 in}

- If it is less than the minimum specification, replace the drive plate with a new one.

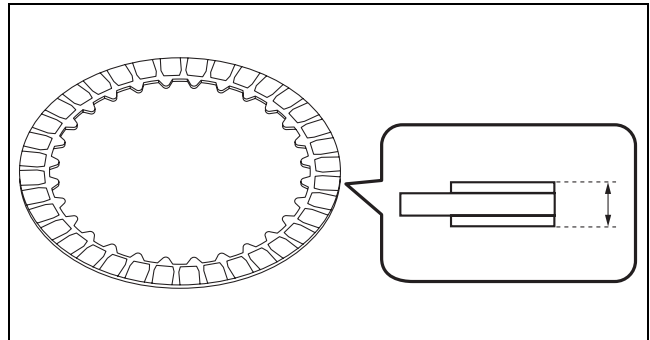

azzjjw00001313

AUTOMATIC TRANSAXLE

Springs and Retainer Component Inspection

1. Measure the free length of the springs and retainer component in four locations (each separated by 90°) and calculate the average value.

Note

- Springs and retainer component size: Outer diameter approx. 79.5 mm {3.13 in}
- Recommended measuring instrument: Vernier caliper

Minimum:

25.4 mm {1.01 in}

- If it is less than the minimum specification, replace the springs and retainer component with a new one.

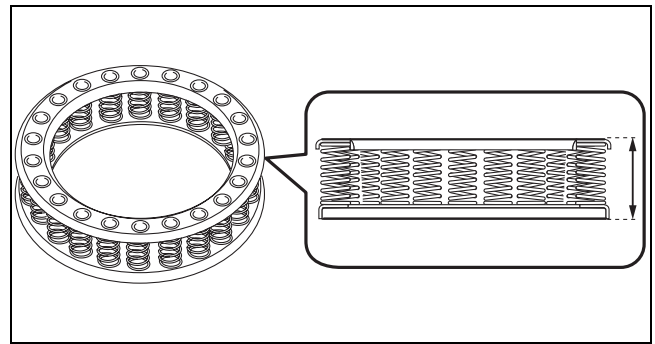

azzjiw00001528

Radial Needle Bearing Inspection (In High Clutch Drum Component)

1. Rotate the radial needle bearing shown in the figure by hand and verify that there is no malfunction in the radial needle bearing (rotation sticking).
 - If there is a malfunction, replace the high clutch drum component with a new one.

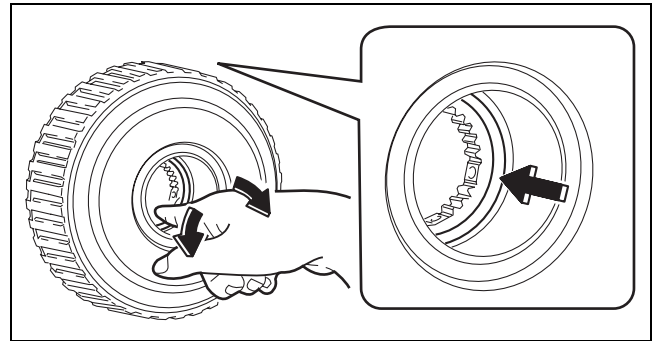

azzjiw00001315

LOW AND REVERSE BRAKE INSPECTION

id051700662700

Drive Plate Inspection

1. Measure the thickness of the drive plate in four locations (each separated by 90°) and calculate the average value.

Caution

- When measuring the thickness of the drive plate, measure the thickness including the facing.
- Measure the thickness of all the drive plates.

Note

- Drive plate size: Outer diameter approx. 174.1 mm {6.854 in}
- Recommended measuring instrument: Micrometer

Minimum:

1.475 mm {0.05808 in}

- If it is less than the minimum specification, replace the drive plate with a new one.

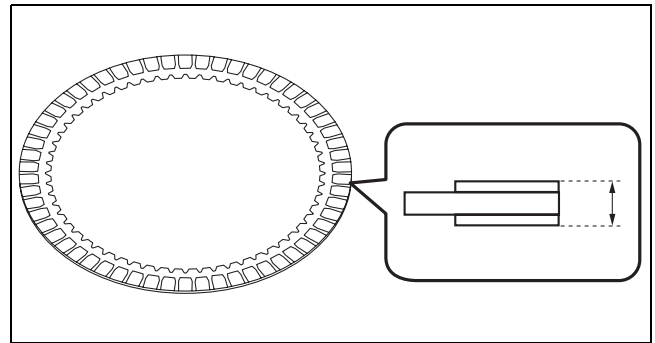

azzjiw00001316

AUTOMATIC TRANSAXLE

2-6 BRAKE INSPECTION

id051700662800

Drive plate inspection

1. Measure the thickness of the drive plate in four locations (each separated by 90°) and calculate the average value.

Caution

- When measuring the thickness of the drive plate, measure the thickness including the facing.
- Measure the thickness of all the drive plates.

Note

- Drive plate size: Outer diameter approx. 171.9 mm {6.768 in}
- Recommended measuring instrument: Micrometer

Minimum:

1.475 mm {0.05808 in}

- If it is less than the minimum specification, replace the drive plate with a new one.

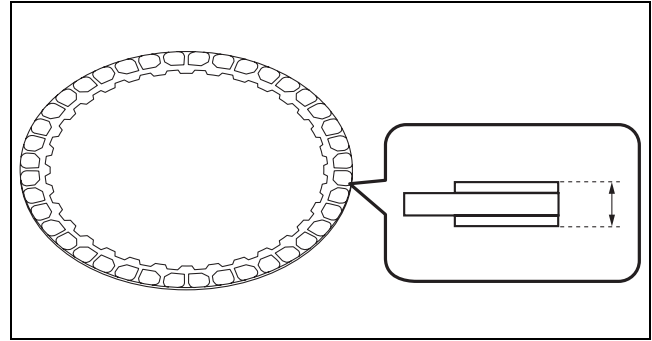

azzjjw00001318

05-17

R-3-5 BRAKE INSPECTION

id051700662900

Drive Plate Inspection

1. Measure the thickness of the drive plate in four locations (each separated by 90°) and calculate the average value.

Caution

- When measuring the thickness of the drive plate, measure the thickness including the facing.
- Measure the thickness of all the drive plates.

Note

- Drive plate size: Outer diameter approx. 169.4 mm {6.669 in}
- Recommended measuring instrument: Micrometer

Minimum:

1.635 mm {0.06438 in}

- If it is less than the minimum specification, replace the drive plate with a new one.

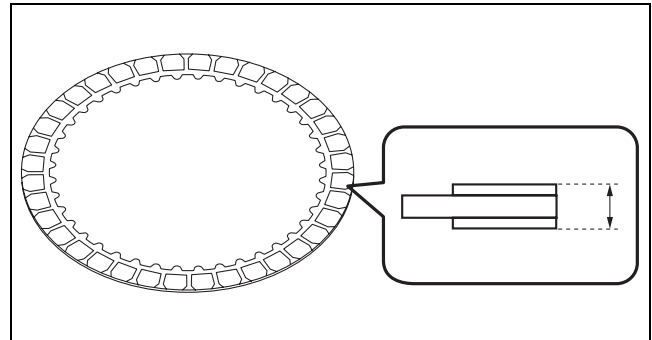

azzjjw00001320

AUTOMATIC TRANSAXLE

ONE-WAY CLUTCH INSPECTION

id051700663000

Caution

- Do not disassemble the one-way clutch. If it has been disassembled, replace the one-way clutch with a new one.

1. Place the one-way clutch on a workbench as shown in the figure.

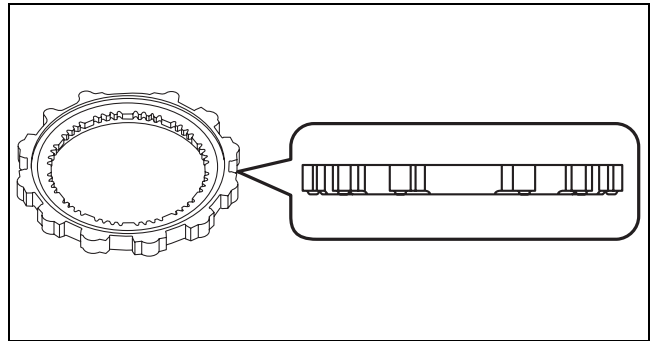

azzjiw00001322

2. Secure the outer plate of the one-way clutch by hand.

A : Secure by hand

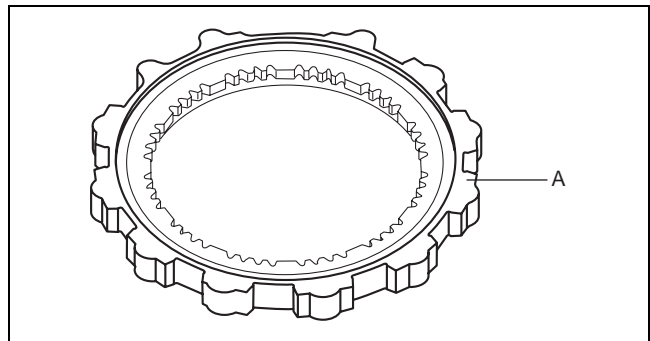

azzjiw00001323

3. Rotate the inner plate of the one-way clutch by hand and verify that it rotates counterclockwise and locks, and does not rotate clockwise.

Caution

- When the inner plate of the one-way clutch is rotated, a ratchet sound occurs because it is a mechanical diode-type one-way clutch, but this does not indicate a malfunction.

- If there is a malfunction, replace the one-way clutch with a new one.

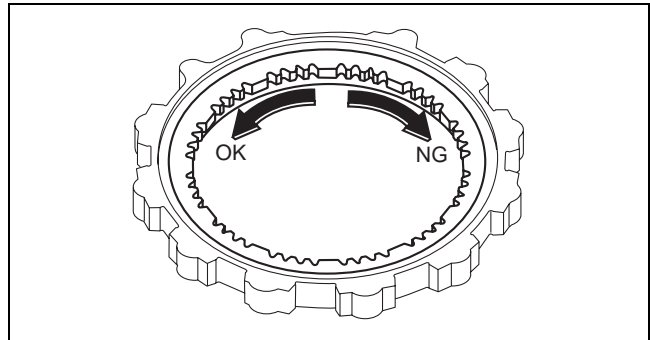

azzjiw00001324

AUTOMATIC TRANSAXLE

LOW CLUTCH HUB INSPECTION

id051700663100

Bush Inner Diameter Inspection

1. Measure the inner diameter of bush in two locations shown in the figure.

Note

- When measuring, measure near the center of the bush avoiding the oil groove, and then calculate the average value of the X and Y directions as shown in the figure.
- Recommended measuring instrument: Cylinder gauge or caliper gauge

Maximum:

31.270 mm {1.2311 in}

- If it is more than the maximum specification, replace the low clutch hub with a new one.

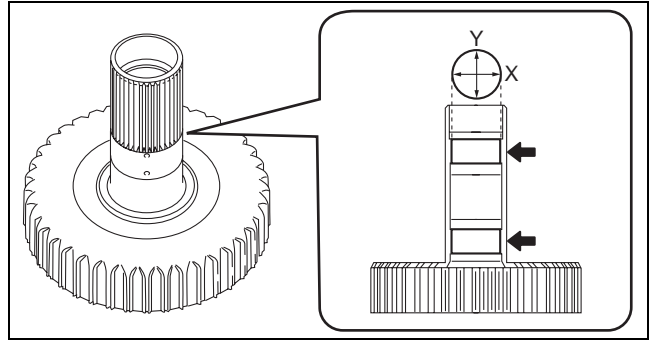

azzjjw00001348

05-17

HIGH CLUTCH HUB INSPECTION

id051700663200

Bush Inner Diameter Inspection

1. Measure the inner diameter of bush in two locations shown in the figure.

Note

- When measuring, measure near the center of the bush avoiding the oil groove, and then calculate the average value of the X and Y directions as shown in the figure.
- Recommended measuring instrument: Cylinder gauge or caliper gauge

Maximum:

18.038 mm {0.71015 in}

- If it is more than the maximum specification, replace the high clutch hub with a new one.

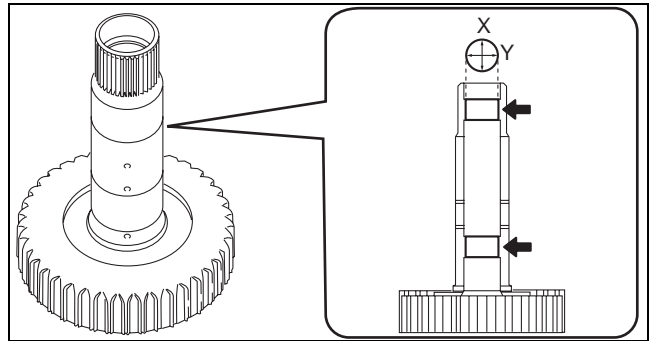

azzjjw00001326

AUTOMATIC TRANSAXLE

id051700663300

OIL PUMP INSPECTION

Side Clearance Inspection

1. Assemble the outer rotor.

A : Mark

B : Assembly direction (oil pump housing side)

Note

- Assemble so that the outer rotor marking is facing the oil pump housing.

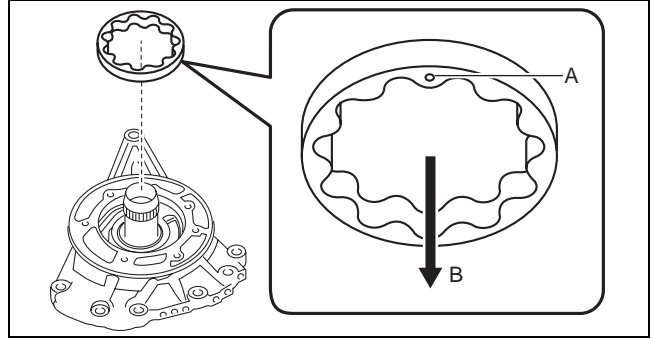

azzjw00001327

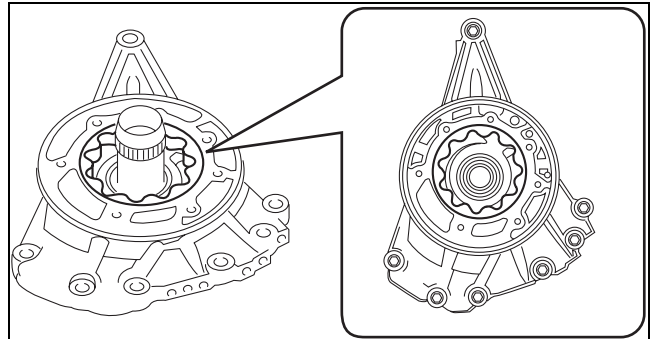

azzjw00001328

2. Assemble the inner rotor.

A : Mark

B : Assembly direction (oil pump housing side)

Note

- Assemble with the inner rotor marking pointed at the oil pump housing.

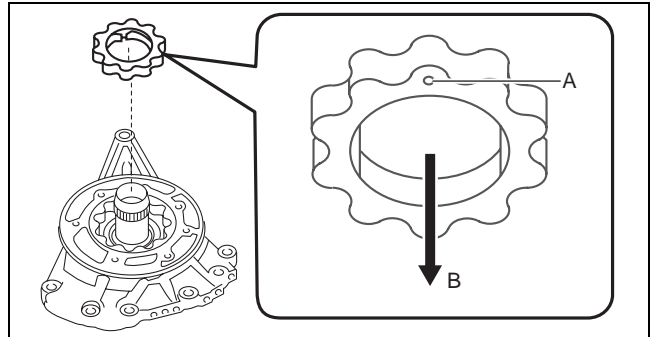

azzjw00001529

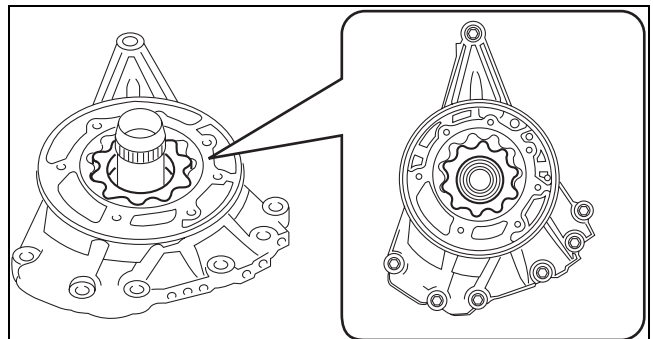

azzjw00001330

AUTOMATIC TRANSAXLE

3. Set the assembled parts on the workbench as shown in the figure.

A : Rubber plate

Caution

- To reduce error during the side clearance measurement, use the rubber plates to adjust the alignment surface of the oil pump housing with the oil pump cover so that it is level.

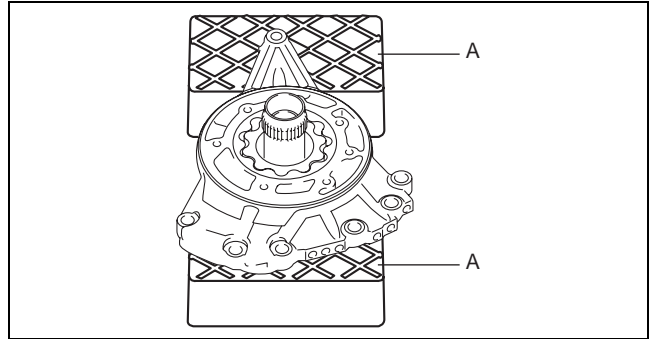

azzjw00001331

4. Measure the side clearance shown in the figure in four locations (each separated by 90°) and calculate the average value.

A : Inner rotor

B : Outer rotor

Caution

- Measure the inner rotor and outer rotor side clearances.

Note

- Recommended measuring instrument:
Thickness gauge, straight edge ruler

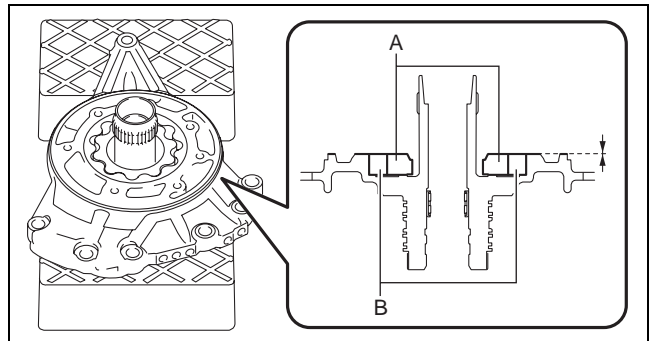

azzjw00001332

Maximum:

- Inner rotor: 0.045 mm {0.0017 in}
- Outer rotor: 0.050 mm {0.0019 in}

- If it is more than the maximum specification, replace the oil pump with a new one.

Note

- Measurement method

(1) Set the straight edge ruler along the alignment surface of the oil pump housing with the oil pump cover as shown in the figure.

A : Straight edge ruler

(2) Measure the gaps between the straight edge ruler and the inner rotor, and the straight edge ruler and the outer rotor using a thickness gauge.

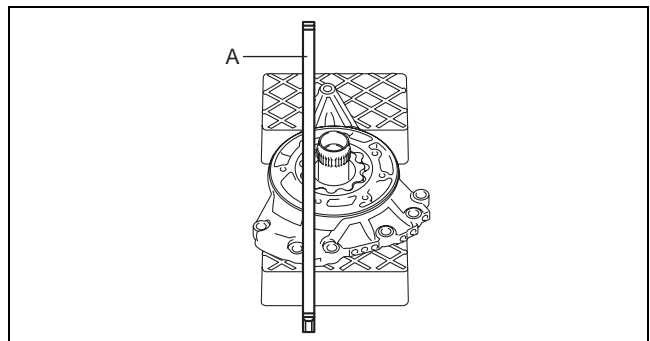

azzjw00001333

5. Take the parts in which the side clearance has been measured off the rubber plates.

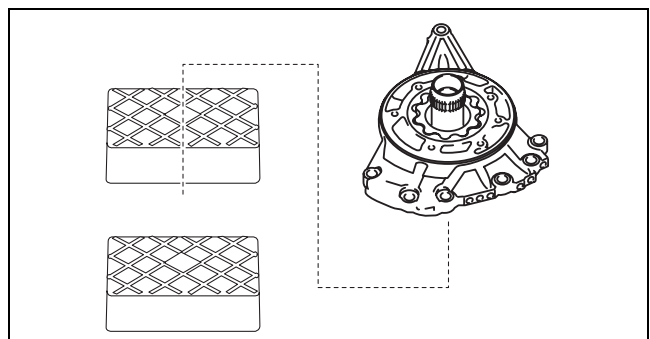

azzjw00001334

AUTOMATIC TRANSAXLE

6. Remove the inner rotor.

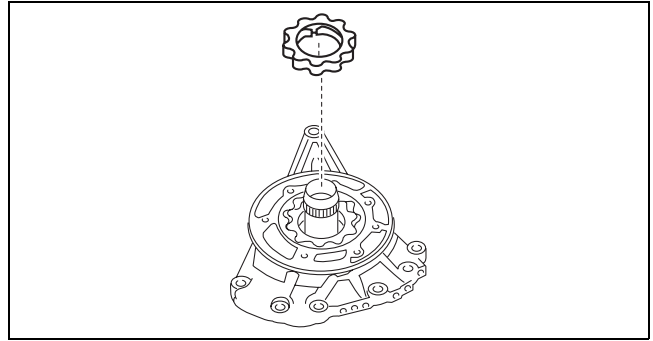

azzjw00001335

7. Remove the outer rotor.

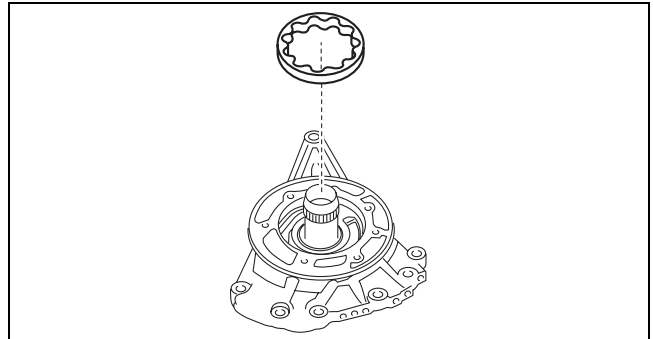

azzjw00001336

Bush Inner Diameter Inspection (In Oil Pump Cover)

1. Measure the inner diameter of the bush shown in the figure.

Note

- When measuring, measure near the center of the bush avoiding the dimple, and then calculate the average value of the X and Y directions as shown in the figure.
- Recommended measuring instrument: Cylinder gauge or caliper gauge

Maximum:

44.006 mm {1.7325 in}

- If it is more than the maximum specification, replace the oil pump cover with a new one.

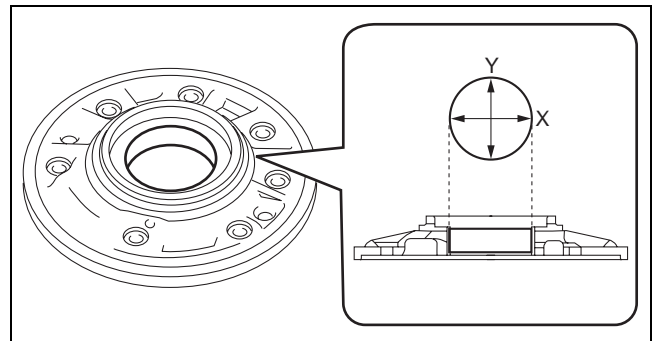

azzjw00001337

Radial Needle Bearing Inspection (In Oil Pump Housing)

1. Rotate the radial needle bearing shown in the figure by hand and verify that there is no malfunction in the radial needle bearing (rotation sticking).

- If there is a malfunction, replace the oil pump with a new one.

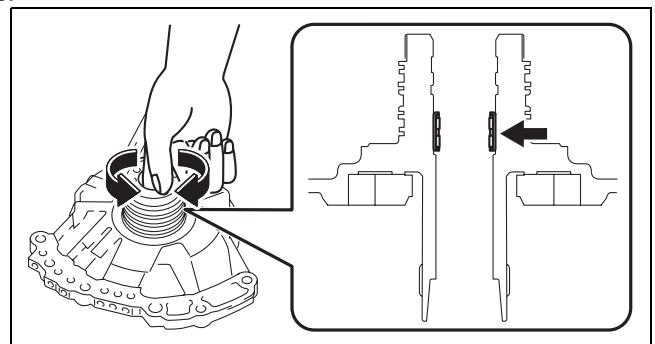

azzjw00001338

AUTOMATIC TRANSAXLE

END COVER INSPECTION

id051700663400

Radial Needle Bearing Inspection

1. Rotate the radial needle bearing shown in the figure by hand and verify that there is no malfunction in the radial needle bearing (rotation sticking).
 - If there is a malfunction, replace the end cover with a new one.

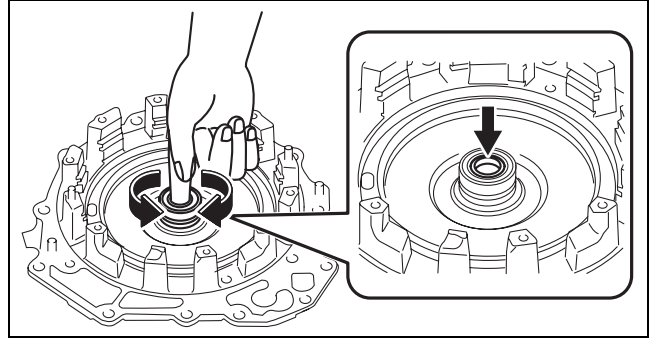

azzjjw00001340

05-17

OIL COOLER INSPECTION

id051700663500

1. Prepare a clean oil receptacle.

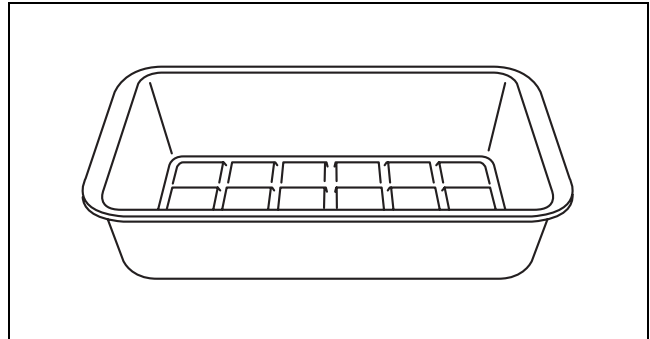

azzjjw00001341

2. Blow compressed air into the oil passage shown in the figure and drain the ATF in the oil cooler.

Warning

- Always wear protective eye wear when using the air compressor. Otherwise, ATF or dirt particles blown off by the air compressor could get into the eyes.

Caution

- Perform the work at a position where the ATF in the oil cooler can be drained into a clean oil receptacle.
- To prevent damage to parts, always use an air compressor which is adjusted to the indicated pressure.

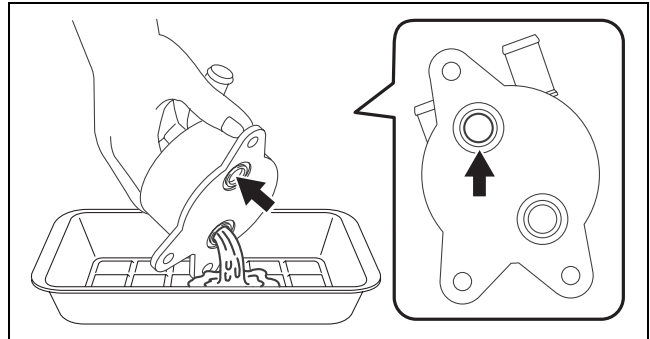

azzjjw00001342

Compressed air pressure

491—882 kPa {5.01—8.99 kgf/cm², 71.3—127.0 psi}

3. Dispose of the ATF in the oil receptacle and clean the oil receptacle.

AUTOMATIC TRANSAXLE

4. Add water into the clean oil receptacle.

A : Water

B : Approx. 70 mm {2.8 in}

Note

- Add water until the water depth reaches approx. 70 mm {2.8 in}.

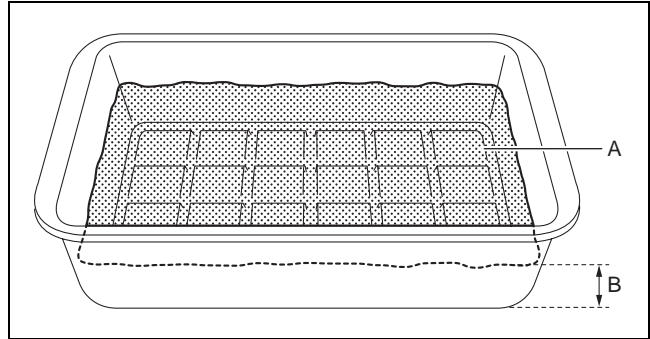

azzjw00001343

5. Cover the oil passage by hand.

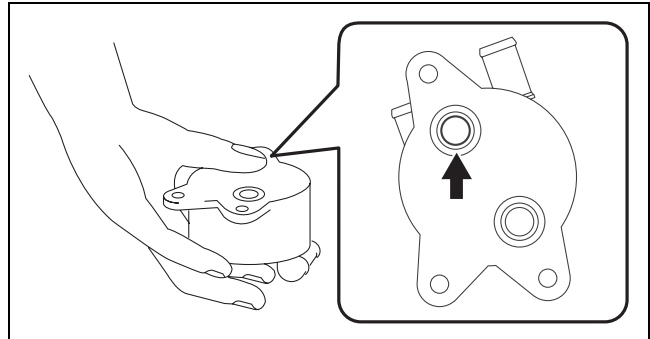

azzjw00001344

6. Immerse the oil cooler in the water in the oil receptacle to the level shown in the figure.

Caution

- Be careful not to allow water to penetrate the oil passage shown in the figure. If water penetrates the oil passage, flush and drain the water in the oil cooler oil passage. (See 05-17-147 OIL COOLER CLEANING.)

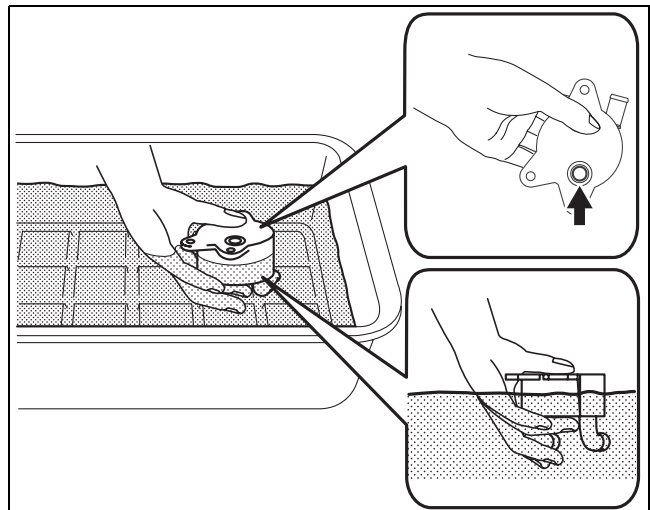

azzjw00001345

AUTOMATIC TRANSAXLE

7. Blow compressed air into the oil passage shown in the figure, apply compressed air pressure to the oil cooler for 3 min, and verify that there is no air leakage from the part which was soaked in water in the oil cooler.

Warning

- Always wear protective eye wear when using the air compressor. Otherwise, ATF or dirt particles blown off by the air compressor could get into the eyes.

Caution

- To prevent damage to parts, always use an air compressor which is adjusted to the indicated pressure.

Note

- A small amount of air leakage due to the compressed air pressure from the area where the oil passage is covered by your hand is of no concern, therefore, apply compressed air pressure to the oil cooler for 3 min.

Compressed air pressure

150—200 kPa {1.53—2.03 kgf/cm², 21.8—29.0 psi}

- If there is a malfunction, replace the oil cooler with a new one.
8. Remove the oil cooler from the water and wipe off any water remaining around the oil cooler.

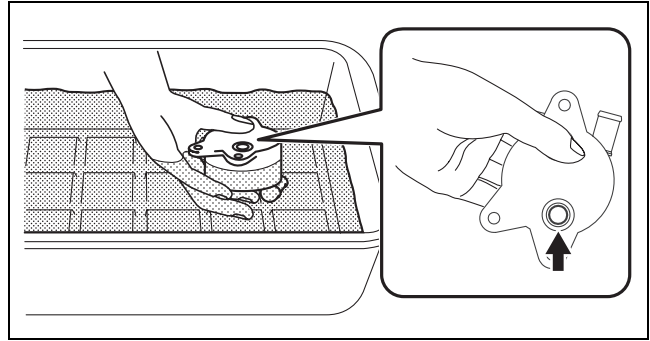

azzjw00001346

05-17

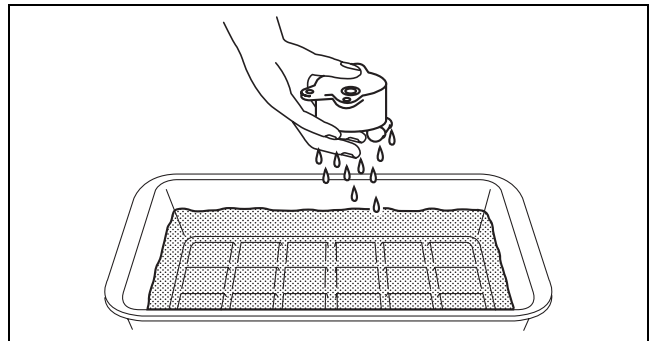

azzjw00001347

9. Dispose of the water in the oil receptacle and clean the oil receptacle.

AUTOMATIC TRANSAXLE

AUTOMATIC TRANSAXLE ASSEMBLY

id051700664400

Structural View Automatic transaxle 1

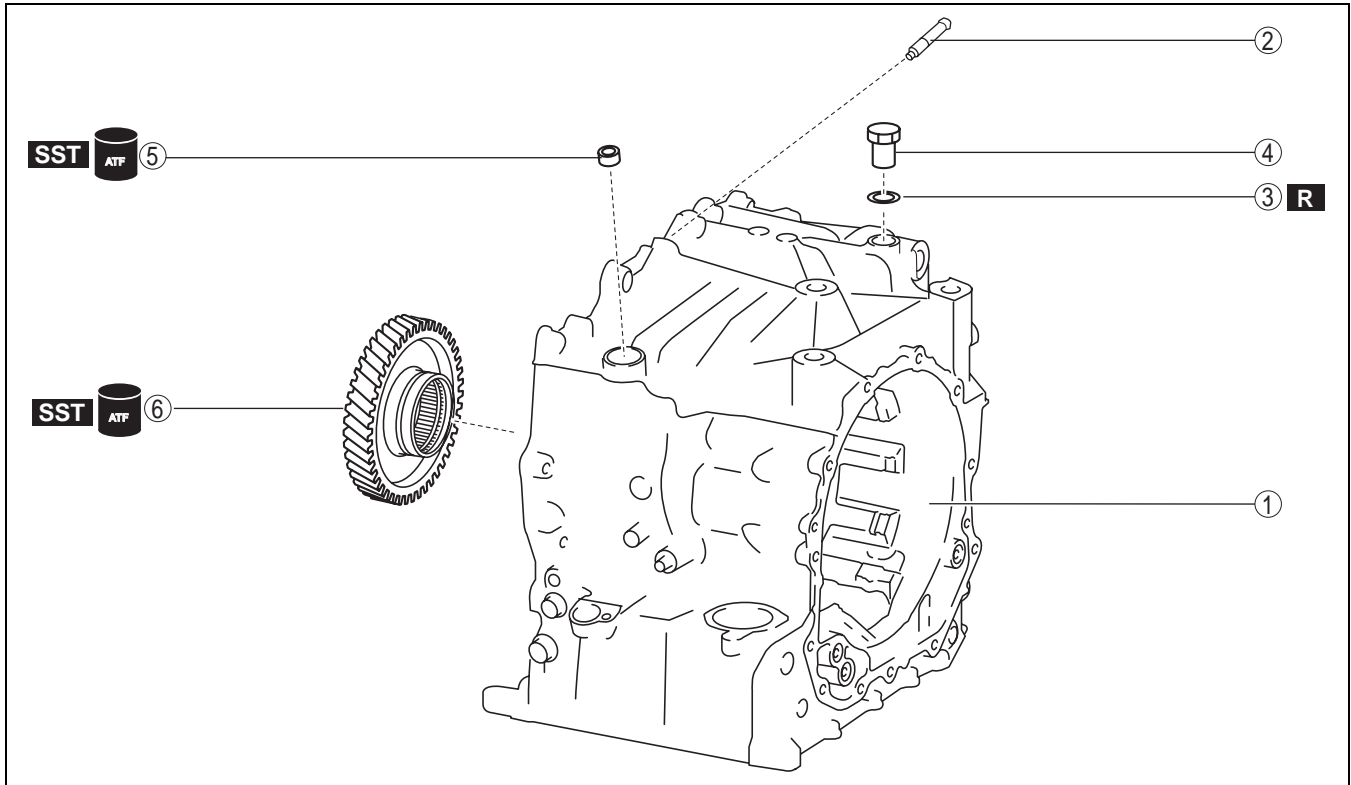

azzjiw00001554

1	Transaxle case
2	Breather pipe
3	Gasket

4	Plug (M18×1.5 bolt, length to approx. 21.5 mm {0.846 in})
5	Radial needle bearing
6	Primary gear

AUTOMATIC TRANSAXLE

Automatic transaxle 2

05-17

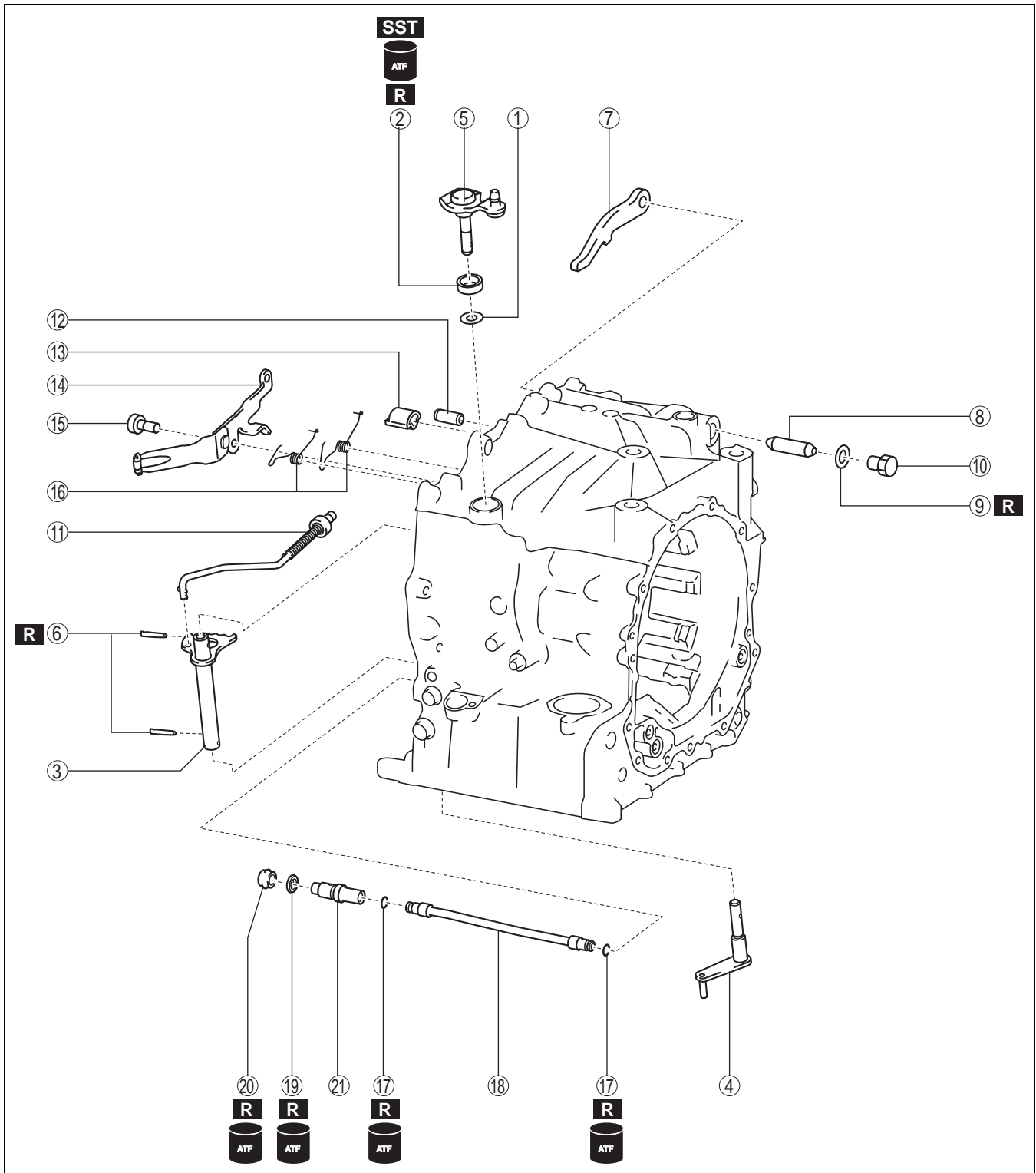

azzjjw00001555

1	Washer
2	Oil seal
3	Manual plate component
4	Parking assist lever component
5	Parking shift lever component
6	Roll pin
7	Parking pawl
8	Parking pawl shaft

9	Gasket
10	Plug (M14×1.5, length to approx. 10 mm {0.39 in})
11	Parking rod component
12	Parking pawl pin
13	Support actuator
14	Detent bracket component
15	2 bolts (M8×1.25 bolt, length to approx. 16 mm {0.63 in})

AUTOMATIC TRANSAXLE

16	Pawl return spring
17	O-ring (outer diameter approx. 11.6 mm {0.457 in}, thickness approx. 1.9 mm {0.075 in})
18	Oil pipe

19	Gasket
20	Gasket
21	Connector

Automatic transaxle 3

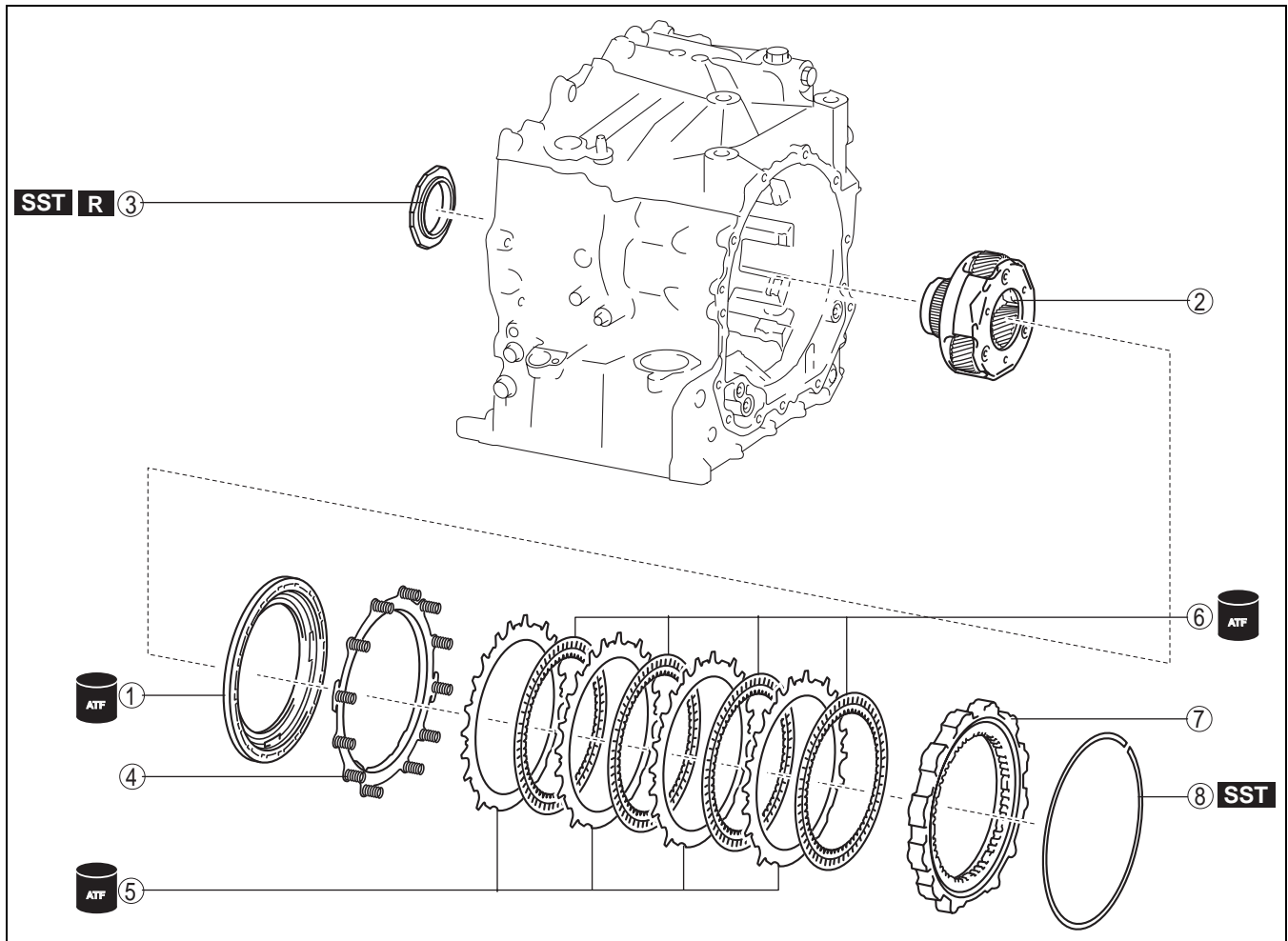

azzjiw00001556

1	Low and reverse brake piston
2	Front planetary gear
3	Locknut
4	Springs and retainer component (inner diameter approx. 152.3 mm {5.996 in})

5	Driven plate (inner diameter approx. 149.6 mm {5.890 in})
6	Drive plate (outer diameter approx. 174.1 mm {6.854 in})
7	One-way clutch
8	Snap ring (outer diameter approx. 198.0 mm {7.795 in}) (selection)

AUTOMATIC TRANSAXLE

Automatic transaxle 4

05-17

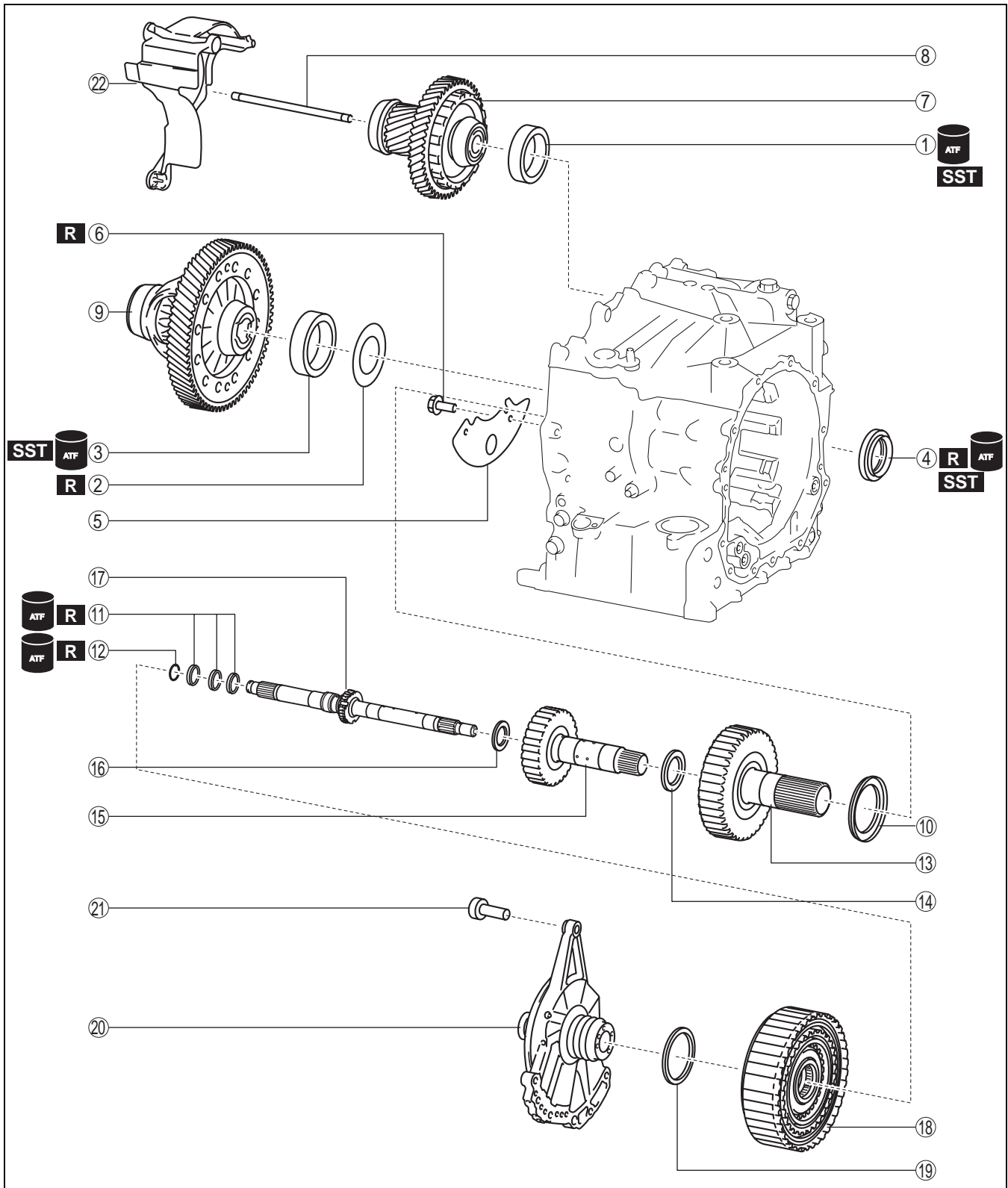

azzjjw00001557

1	Bearing race (outer diameter approx. 70 mm {2.8 in})
2	Shim (outer diameter approx. 79 mm {3.1 in}, thickness approx. 0.5 mm {0.02 in})
3	Bearing race (outer diameter approx. 80 mm {3.1 in})
4	Oil seal (outer diameter approx. 63 mm {2.5 in})

5	Baffle plate
6	2 bolts (M6×1.0 bolt, length to approx. 15 mm {0.59 in})
7	Secondary gear and output gear
8	Oil pipe
9	Ring gear and differential

05-17-183

AUTOMATIC TRANSAXLE

10	Thrust needle bearing (outer diameter approx. 80.3 mm {3.16 in})
11	Seal ring (outer diameter approx. 24.4 mm {0.961 in}, thickness approx. 1.5 mm {0.059 in})
12	D-ring (outer diameter approx. 16.4 mm {0.646 in}, thickness approx. 2.4 mm {0.094 in})
13	Low clutch hub
14	Thrust needle bearing (outer diameter approx. 51.3 mm {2.02 in})
15	High clutch hub

16	Thrust needle bearing (outer diameter approx. 37.3 mm {1.47 in})
17	Turbine shaft
18	Clutch component
19	Thrust needle bearing (outer diameter approx. 72.7 mm {2.86 in})
20	Oil pump
21	7 bolts (M8×1.25 bolt, length to approx. 31 mm {1.2 in})
22	Baffle plate

* : Length without spring washer is indicated due to bolt with spring washer. Length with spring washer is approx. 13 mm {0.51 in}. In addition, this bolt is applied with thread-locking compound.

Automatic transaxle 5

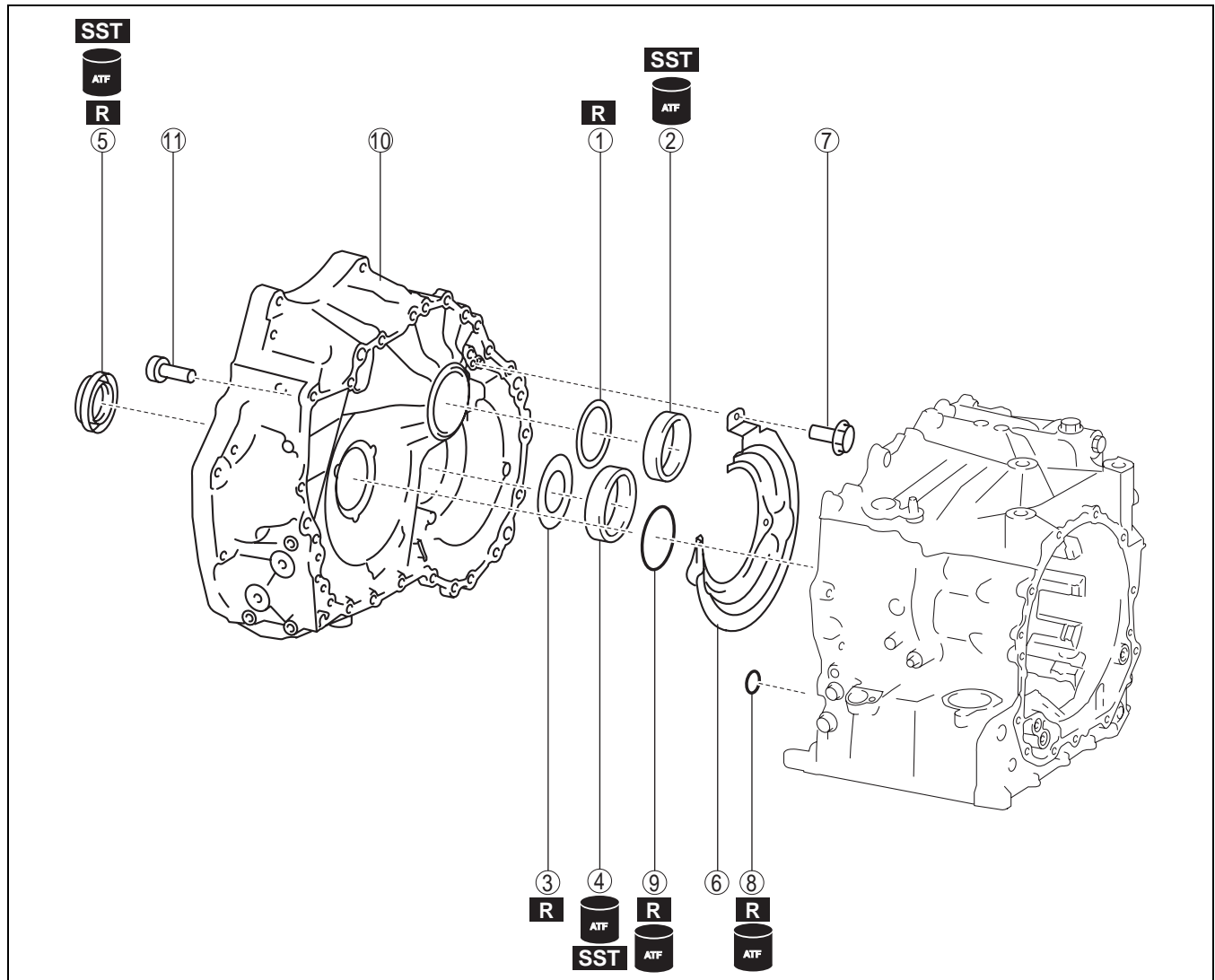

azzjiw00001558

1	Shim (outer diameter approx. 74 mm {2.9 in}) (selection)
2	Bearing race (outer diameter approx. 75 mm {3.0 in})
3	Shim (outer diameter approx. 79 mm {3.1 in}) (selection)
4	Bearing race (outer diameter approx. 80 mm {3.1 in})

5	Oil seal (outer diameter approx. 65 mm {2.6 in})
6	Baffle plate
7	3 bolts (M6×1.0 bolt, length to approx. 14 mm {0.55 in})
8	O-ring (outer diameter approx. 15.6 mm {0.614 in}, thickness approx. 2.4 mm {0.094 in})

AUTOMATIC TRANSAXLE

9	O-ring (outer diameter approx. 73.3 mm {2.89 in}, thickness approx. 3.0 mm {0.12 in})
10	Converter housing

11	24 bolts * (M8×1.25 bolt, length to approx. 28 mm {1.1 in})
----	---

* : Of the 24 bolts, 6 are applied with sealant

05-17

Automatic transaxle 6

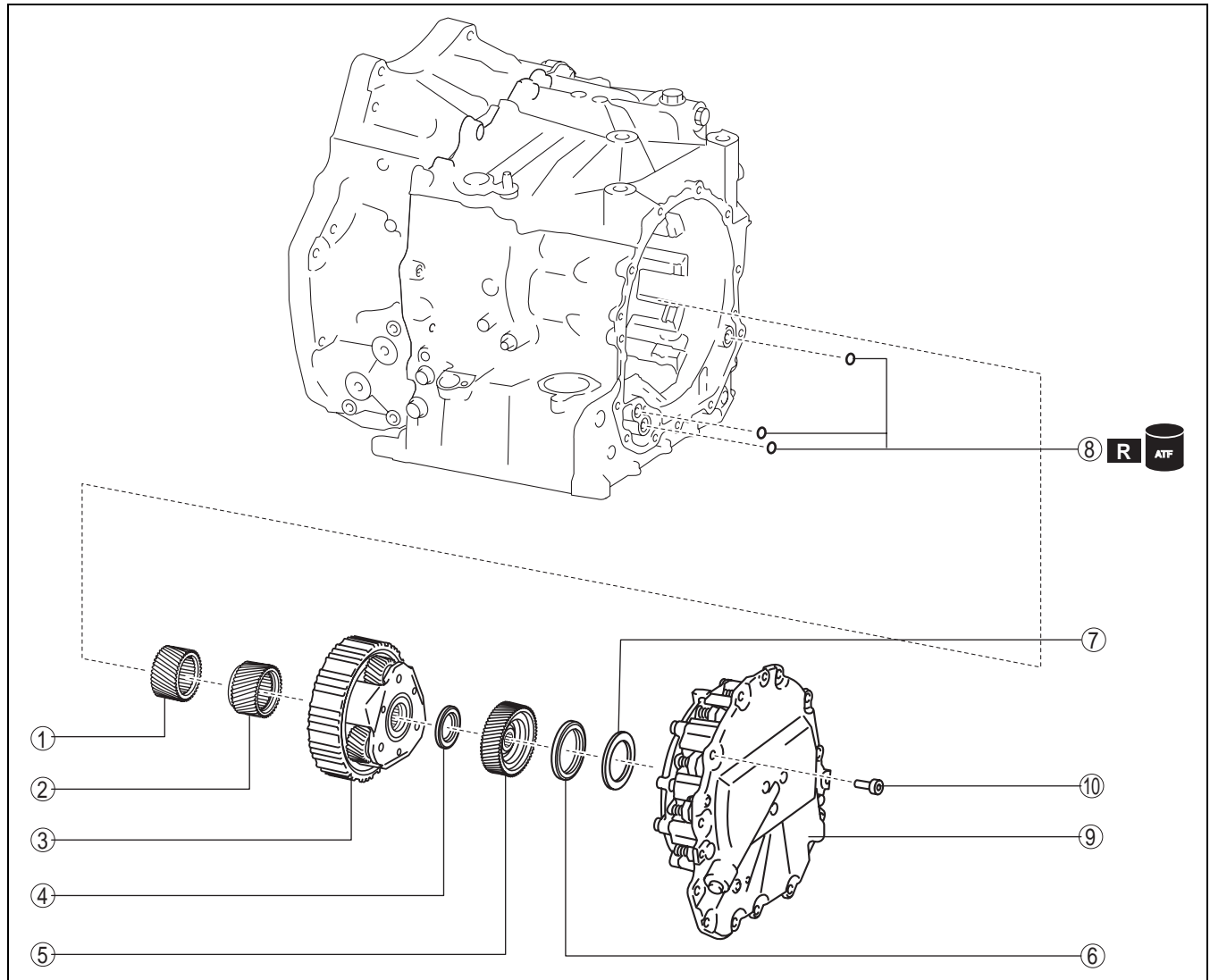

azzijw00001559

1	Front sun gear
2	Rear sun gear
3	Rear planetary gear
4	Thrust needle bearing (outer diameter approx. 44 mm {1.7 in})
5	Reduction sun gear
6	Thrust needle bearing (outer diameter approx. 61.5 mm {2.42 in})

7	Shim (outer diameter approx. 59.5 mm {2.34 in}) (selection)
8	O-ring (outer diameter approx. 15.6 mm {0.614 in}, thickness approx. 2.4 mm {0.094 in})
9	End cover component
10	12 bolts * (M8×1.25 bolt, length to approx. 21 mm {0.83 in})

* : Of the 12 bolts, 2 are applied with sealant

AUTOMATIC TRANSAXLE

Automatic transaxle 7

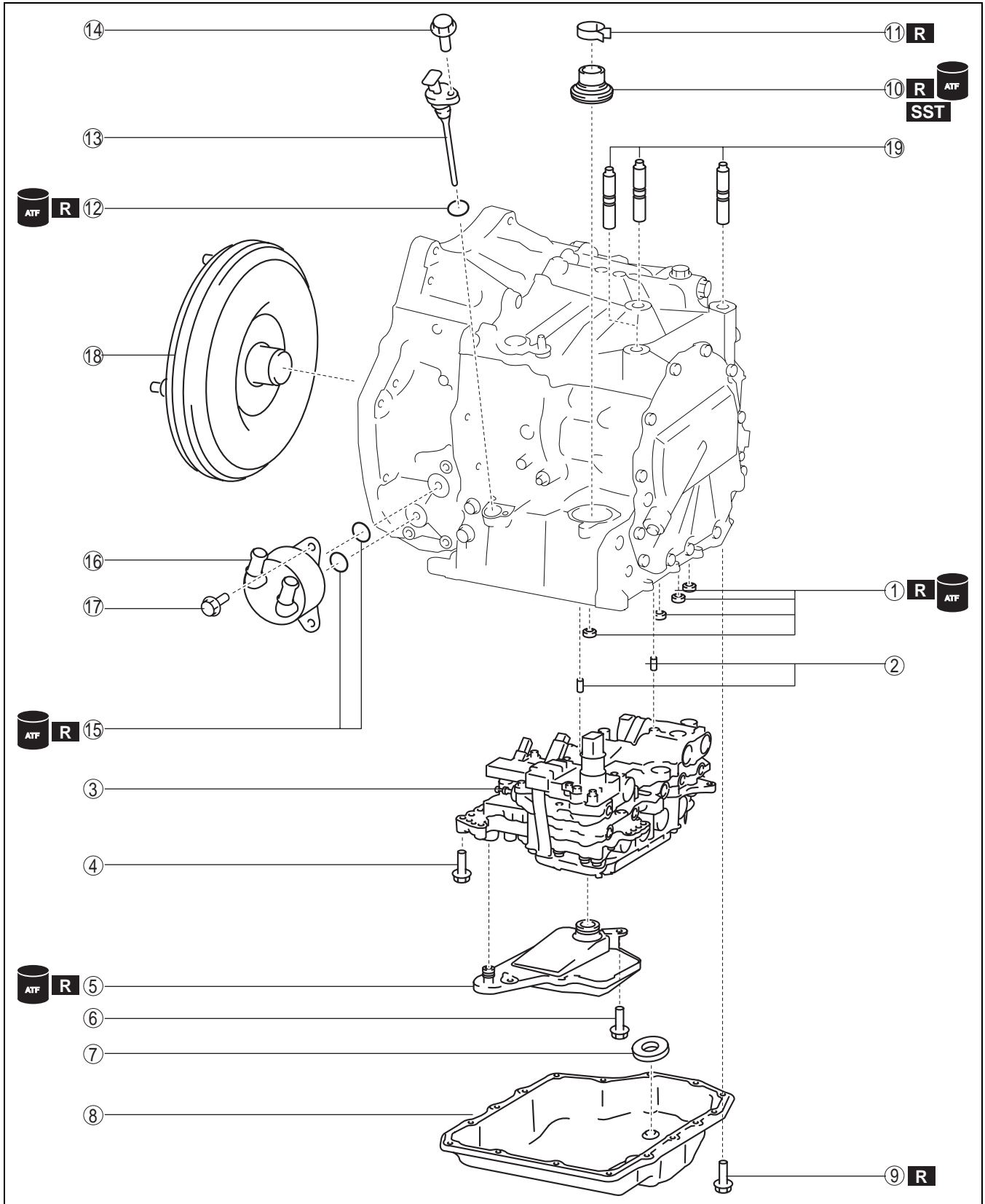

bfw1ua0000002

AUTOMATIC TRANSAXLE

1	Gasket
2	Dowel pin
3	Control valve body
4	11 bolts (M6×1.0 bolt, length to approx. 30 mm {1.2 in})
5	Oil strainer
6	2 bolts (M6×1.0 bolt, length to approx. 16 mm {0.63 in})
7	Magnet
8	Oil pan
9	16 bolts (M6×1.0 bolt, length to approx. 15 mm {0.59 in}*)

10	Oil seal
11	Hose clamp
12	O-ring (outer diameter approx. 16.6 mm {0.654 in}, thickness approx. 2.4 mm {0.094 in})
13	Dipstick
14	Bolt (M6×1.0 bolt, length to approx. 16 mm {0.63 in})
15	O-ring (outer diameter approx. 24.4 mm {0.961 in}, thickness approx. 2.4 mm {0.094 in})
16	Oil cooler
17	3 bolts (M8×1.25 bolt, length to approx. 25 mm {0.98 in})
18	Torque converter
19	Stud bolt

05-17

* : Length without spring washer is indicated due to bolt with spring washer. Length with spring washer is approx. 13 mm {0.51 in}.

Assembly Procedure

1. Assemble the parts in the following order.

Note

- Assemble the parts in the following order because the parts in the transaxle may be used for measurement/adjustment.

- (1) Oil pump (See 05-17-243 OIL PUMP ASSEMBLY)
 - (2) Clutch component (See 05-17-247 CLUTCH COMPONENT ASSEMBLY)
 - (3) Rear planetary gear (See 05-17-259 REAR PLANETARY GEAR ASSEMBLY)
 - (4) Reduction planetary gear (See 05-17-261 REDUCTION PLANETARY GEAR ASSEMBLY)
 - (5) Secondary gear and output gear (See 05-17-263 SECONDARY GEAR AND OUTPUT GEAR ASSEMBLY)
 - (6) Ring gear and differential (See 05-17-266 RING GEAR AND DIFFERENTIAL ASSEMBLY)
 - (7) End cover component (See 05-17-273 END COVER COMPONENT ASSEMBLY)
 - (8) Control valve body (See 05-17-288 CONTROL VALVE BODY ASSEMBLY)
2. If the transaxle case is replaced with a new one, perform the following procedure:
 - (1) Remove the stud bolts.

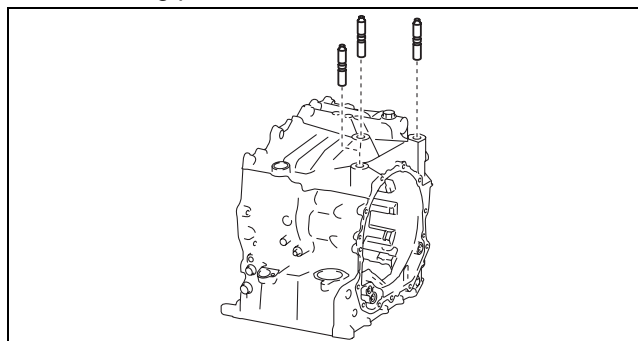

azzjw00000534

AUTOMATIC TRANSAXLE

(2) Assemble a new breather pipe to the position shown in the figure.

Note

- Lightly tap and assemble so as not damage the breather pipe.

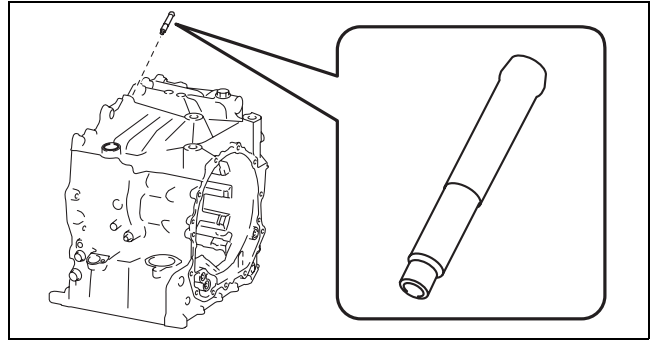

azzjiw00000535

A : 25—27 mm {1.0—1.06 in}

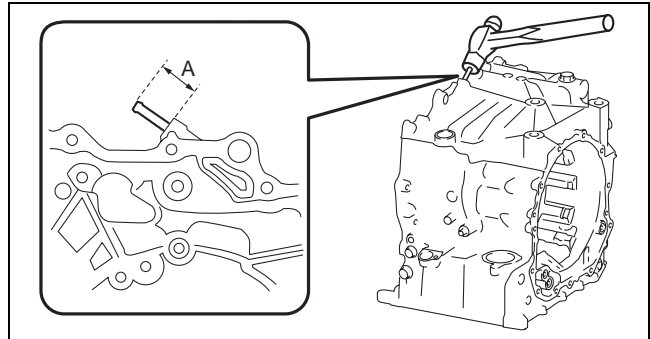

azzjiw00000536

(3) Assemble the plug and new gasket in the order shown in the figure..

1	Gasket
2	Plug (M18×1.5 bolt, length to approx. 21.5 mm {0.846 in})

Caution

- If a gasket is reused it could cause ATF leakage, therefore use a new gasket.

Plug tightening torque

39—59 N·m {4.0—6.0 kgf·m, 29—43 ft·lbf}

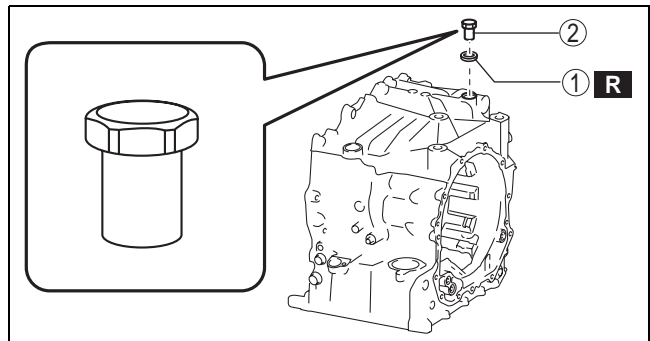

azzjiw00000537

AUTOMATIC TRANSAXLE

- (4) Assemble a new radial needle bearing using the following procedure:
- 1) Apply ATF (ATF FZ) to the engagement area of the new radial needle bearing and transaxle case.
 - 2) Assemble the new radial needle bearing to the position shown in the figure using the SSTs.

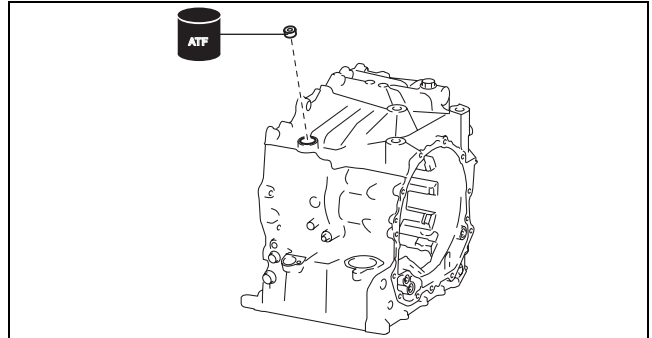

azzjw00001210

A : 1.9—2.9 mm {0.08—0.11 in}

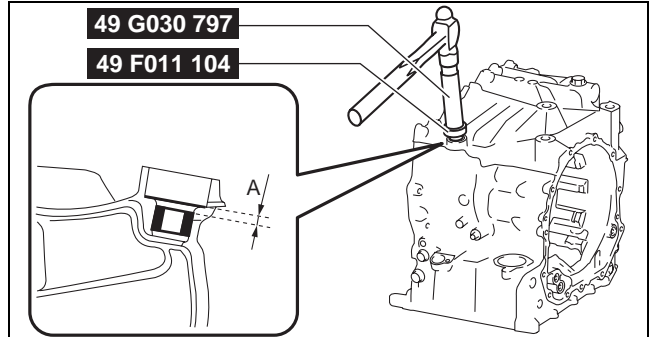

azzjw00001253

3. Install the transaxle case to the SST (engine stand) using the following procedure:

- (1) Install the SSTs to the transaxle case using the following procedure.

Note

- When installing the SST (49 L010 1A0) to the transaxle case (stud bolt holes), use part number: 9YA02 1440 or M14×1.5 bolts, length to 100 mm {3.94 in}.
- When installing the SST (49 UN30 3050) to the transaxle case, use part number: 9YA02 1015, or M10×1.5 bolts, length to 35 mm {1.4 in}.

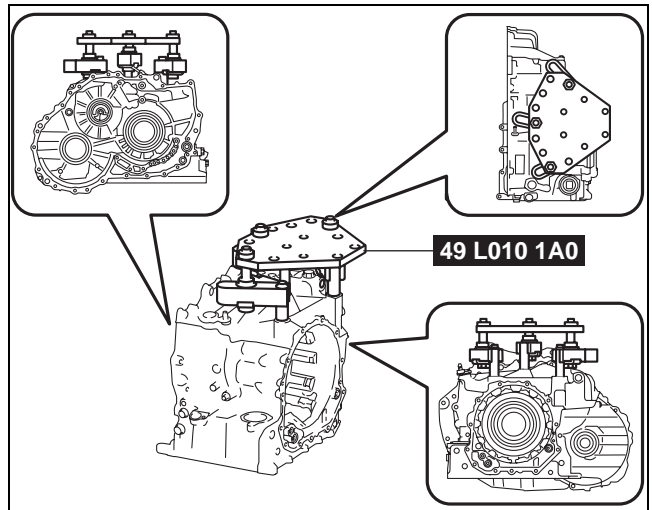

azzjw00000540

- 1) Temporarily install the arms (49 L010 102) using part number: 9YA02 1440, or M14×1.5 bolts, length to 100 mm {3.94 in}.

A : Part number: 9YA02 1440, or M14×1.5 bolt, length to 100 mm {3.94 in}

Note

- To adjust the installation position of the SST in Step 3), temporarily tighten the bolts.

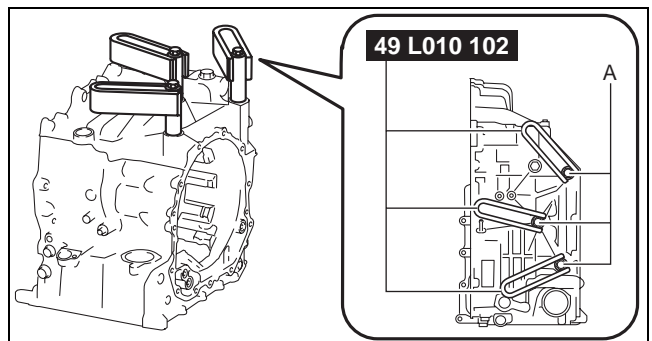

azzjw00000541

AUTOMATIC TRANSAXLE

2) Assemble the SST (49 L010 1A0).

- A : Washer
B : Approx. 20 mm {0.79 in}
C : Approx. 26 mm {1.0 in}
D : Approx. 47 mm {1.9 in}

Note

- Use bolts (49 L010 105) with a length of 138 mm {5.43 in}.

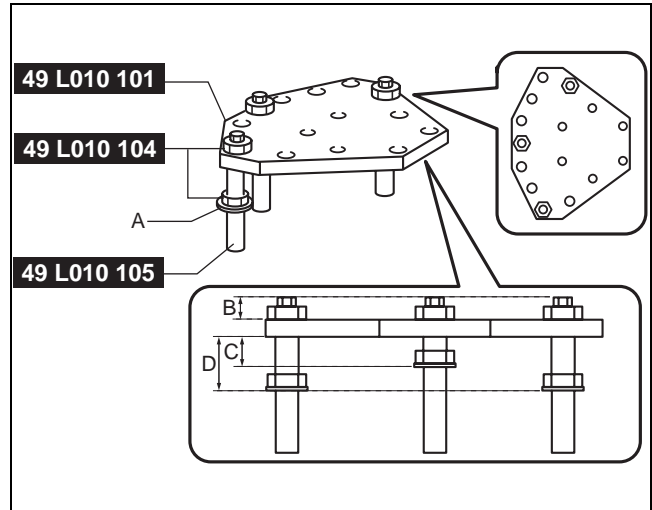

azzjiw00000542

3) Install the SST assembled in Step 2).

- A : Washer
B : Level out

Note

- Adjust so that the plate (49 L010 101) and arms (49 L010 102) are level, and install.

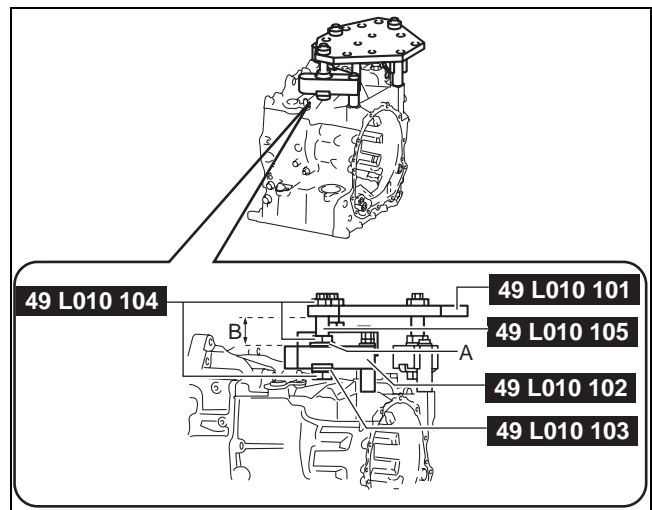

azzjiw00000543

4) Verify that nothing other than the SST arms (49 L010 102) installation area contacts the transaxle case and breather pipe.

Caution

- If something other than the SST arms (49 L010 102) installation area contacts the transaxle case and breather pipe, readjust the SST to prevent damaging the part.

5) Tighten the nuts and bolts.

Tightening torque

- Bolt:** Part number: 9YA02 1440, or M14×1.5 bolt, length to 100 mm {3.94 in}
40—52 N·m {4.1—5.3 kgf·m, 30—38 ft·lbf}
- Nut:** 49 L010 104
140—160 N·m {15—16 kgf·m, 104—118 ft·lbf}

AUTOMATIC TRANSAXLE

- (2) Install the transaxle case to the SST (engine stand) using part number: 9YA02 A220, or M12×1.75 bolts, length to 40 mm {1.6 in}.

Caution

- For safety purposes, perform the procedure using two people, one installs the transaxle case to the SST and the other supports the transaxle case.

Note

- Tighten the four locations with bolts and securely install the transaxle case to the SST (engine stand).

A : Part number: 9YA02 A220, or M12×1.75 bolt, length to 40 mm {1.6 in}

Tightening torque

88—118 N·m {9.0—12 kgf·m, 65—87 ft·lbf}

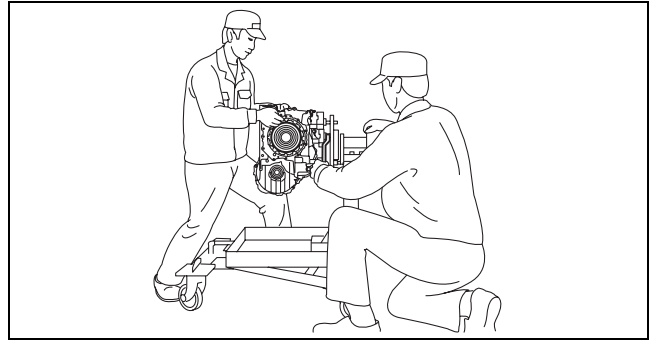

azzjw00000544

05-17

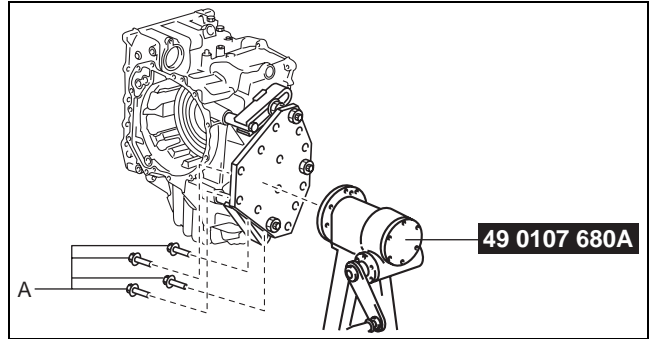

azzjw00000545

4. Assemble the primary gear using the following procedure:

Note

- Perform this procedure only if the transaxle case is replaced with a new one.

- (1) Apply ATF (ATF FZ) to the engagement area of the primary gear and angular contact ball bearing.
- (2) Assemble the primary gear on the angular contact ball bearing.

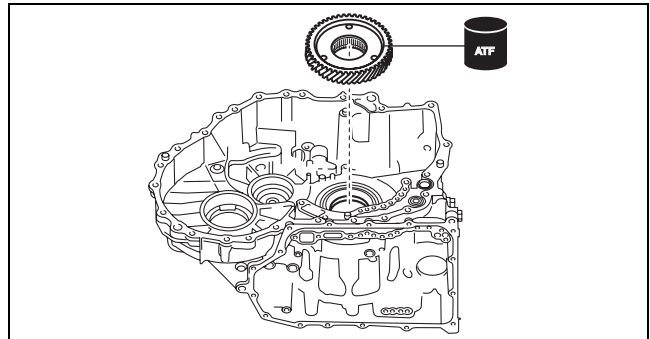

azzjw00000546

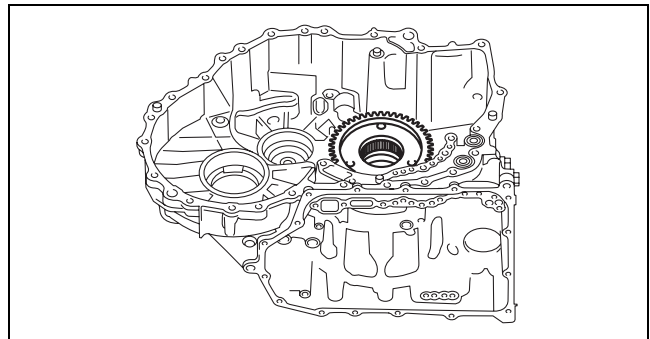

azzjw00000547

AUTOMATIC TRANSAXLE

(3) Install the SSTs.

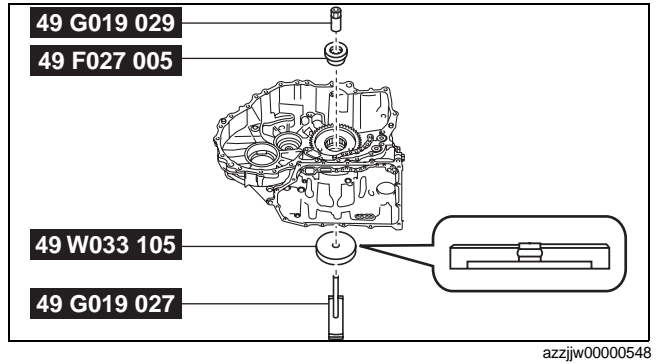

azzjw00000548

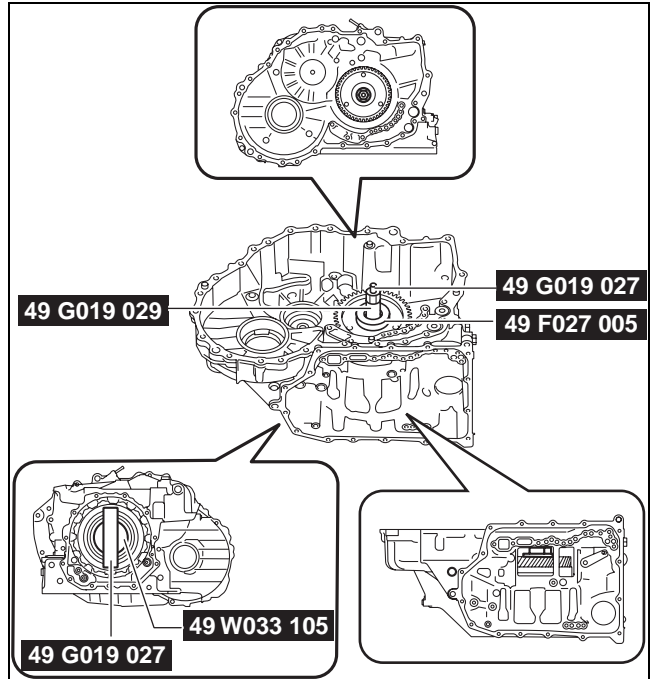

azzjw00000549

(4) Lock the SST (49 G019 027) against rotation using a flathead screwdriver, tighten the SST (49 G019 029), and assemble the primary gear.

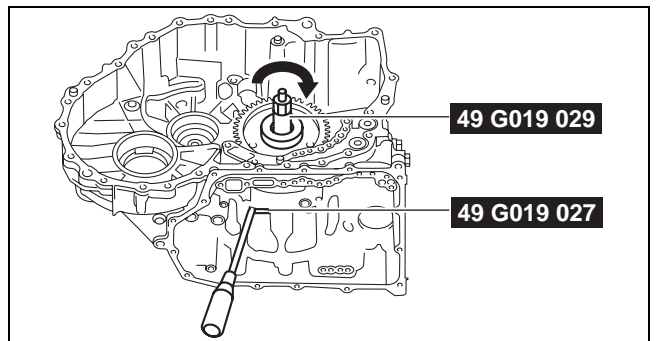

azzjw00000550

AUTOMATIC TRANSAXLE

- (5) Loosen the SST (49 G019 029) and remove the SSTs.

Note

- Lock the SST (49 G019 027) against rotation using a flathead screwdriver and loosen the SST (49 G019 029).

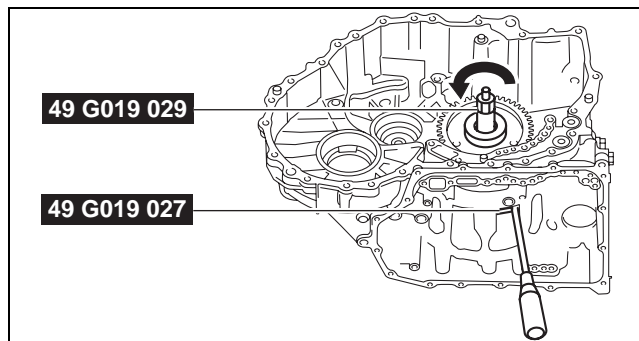

azzijw00000551

05-17

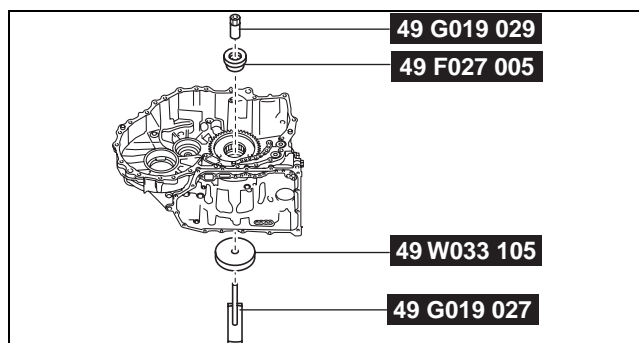

azzijw00000552

5. Assemble the washer.

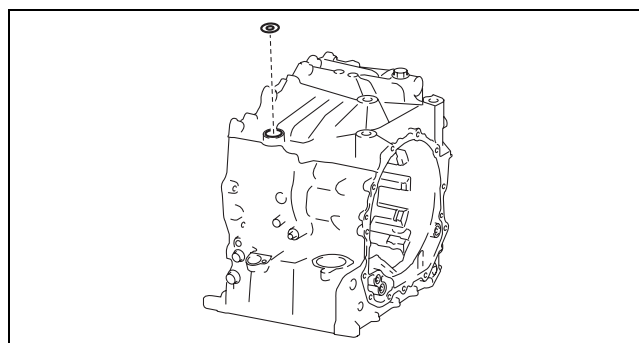

azzijw00000553

AUTOMATIC TRANSAXLE

6. Assemble a new oil seal using the following procedure:

Caution

- If an oil seal is reused it could cause ATF leakage, therefore use a new oil seal.

- (1) Apply ATF (ATF FZ) to the engagement area of the new oil seal and transaxle case.
- (2) Apply ATF (ATF FZ) to the lip of the new oil seal.
- (3) Assemble the new oil seal to the position shown in the figure using the SSTs.

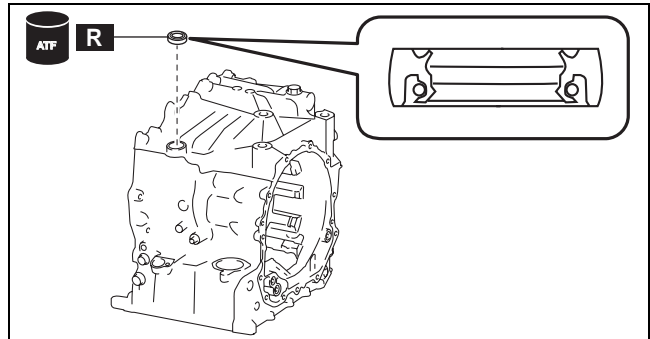

azzjiw00000554

A : -0.3—0.3 mm {-0.01—0.01 in}

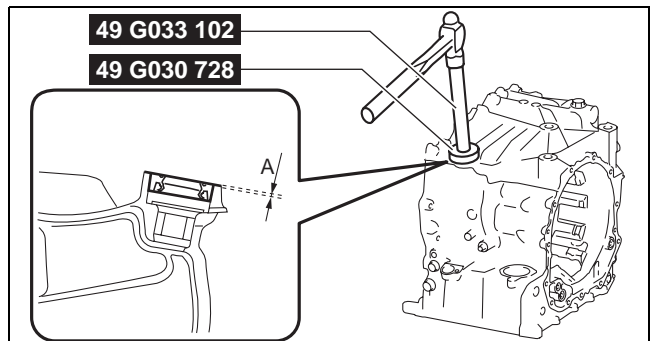

azzjiw00000555

7. Assemble the manual plate component.

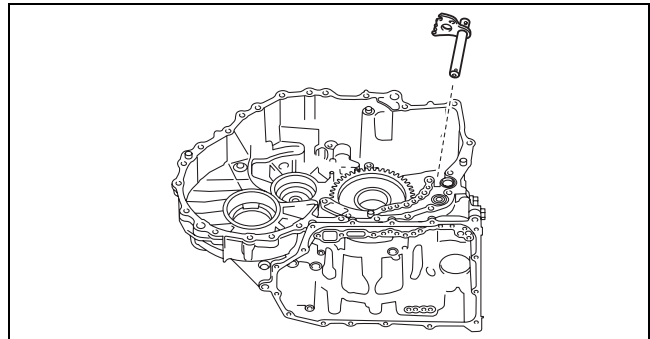

azzjiw00000556

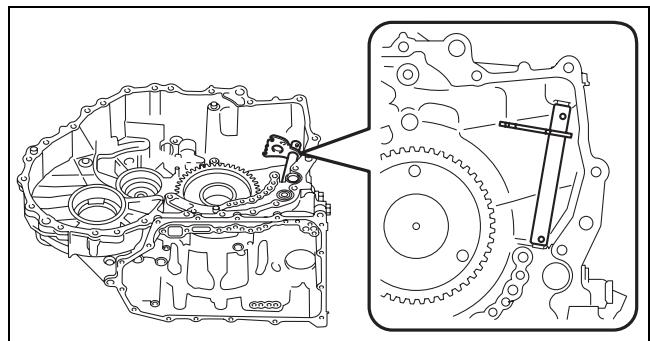

azzjiw00000557

AUTOMATIC TRANSAXLE

8. Assemble the parking assist lever component.

Note

- Pass the end of the parking assist lever component through the assembly hole of the transaxle case, and assemble it to the manual plate component.

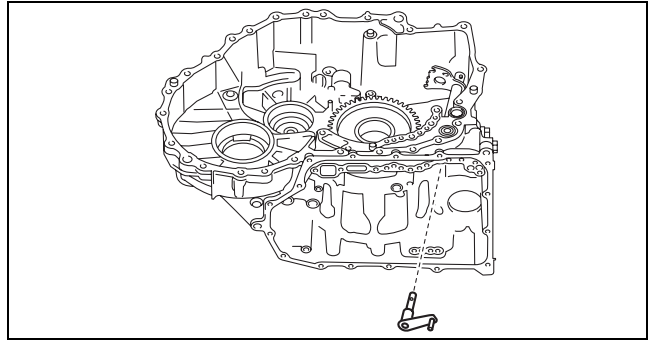

azzjw00000558

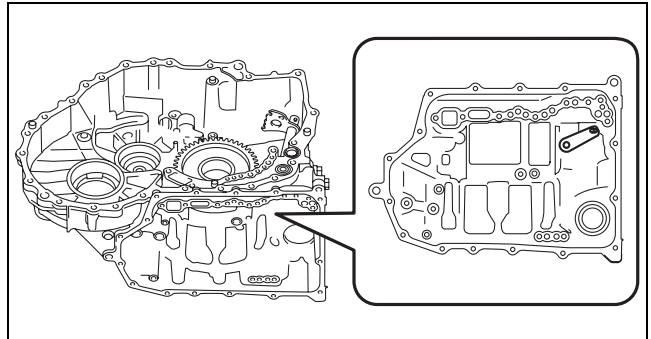

azzjw00000559

9. Assemble the parking shift lever component.

Note

- Pass the end of the parking shift lever component through the assembly hole (radial needle bearing) of the transaxle case, and assemble it to the manual plate component.

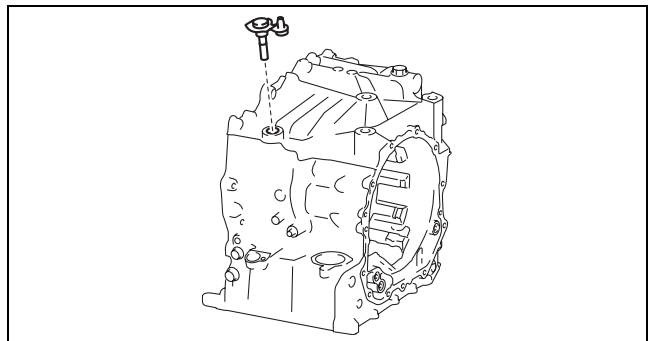

azzjw00000560

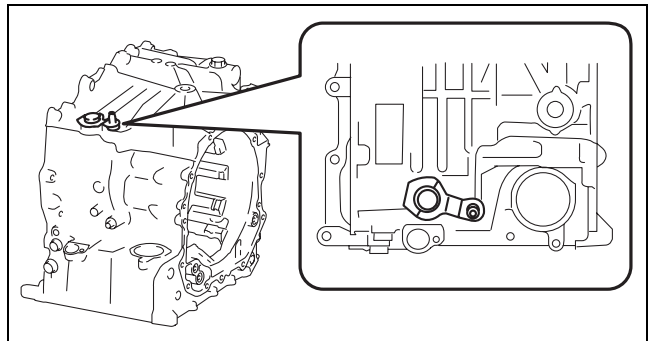

azzjw00000561

05-17

AUTOMATIC TRANSAXLE

10. Assemble the new roll pins using the following procedure:

- (1) Set the manual plate component, parking assist lever component, and the parking shift lever component as shown in the figure and align with the roll pin hole.

- A : Roll pin hole
B : Manual plate component
C : Parking assist lever component
D : Parking shift lever component

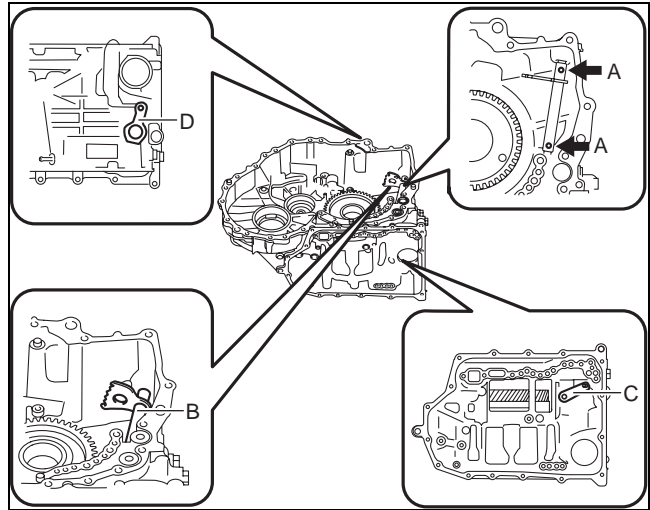

azzjiw00001561

- (2) Assemble the new roll pins to the position shown in the figure using a pin punch.

Note

- Use a pin punch with an end outer diameter of 5 mm {0.197 in} or more.

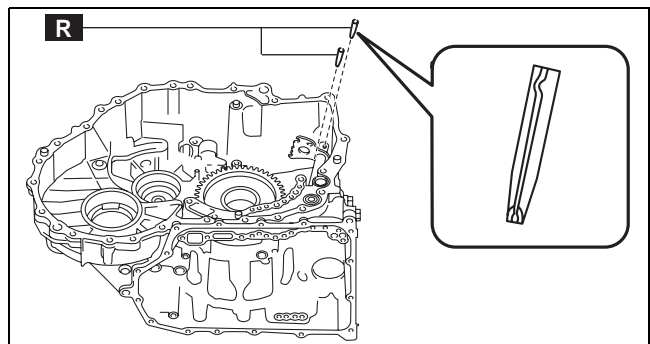

azzjiw00001562

A : 0—1 mm {0—0.03 in}

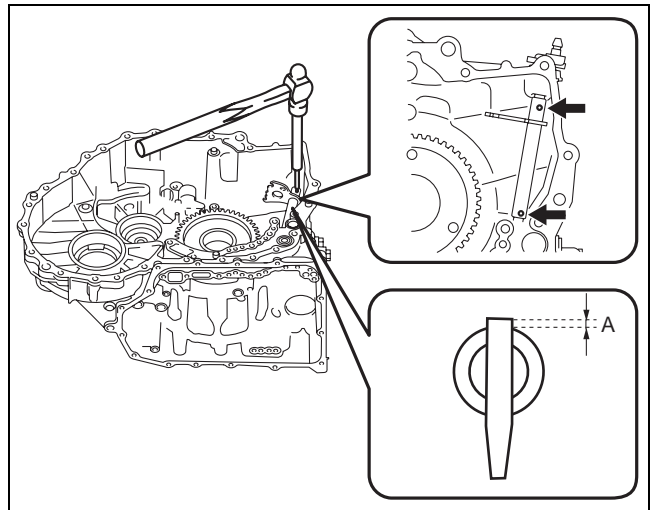

azzjiw00000564

AUTOMATIC TRANSAXLE

11. Assemble the parking pawl.

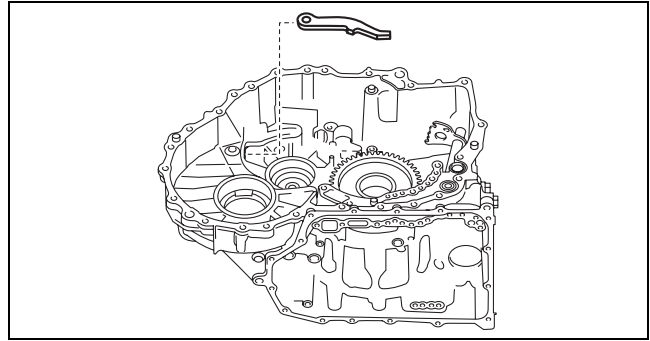

azzjw00000565

05-17

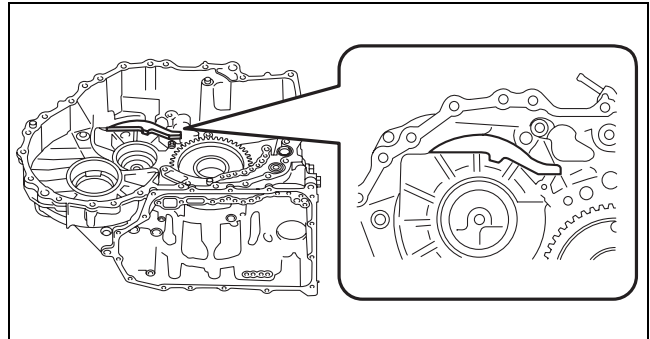

azzjw00000566

12. Assemble the parking pawl shaft using the procedure shown in the figure..

1	Parking pawl shaft
2	Gasket
3	Plug (M14×1.5, length to approx. 10 mm {0.39 in})

Caution

- If a gasket is reused it could cause ATF leakage, therefore use a new gasket.

Note

- Pass the parking pawl shaft through the assembly holes of the transaxle case and the parking pawl and assemble.

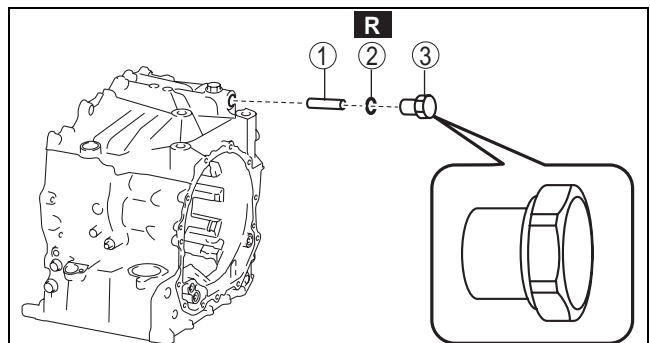

azzjw00000567

Plug tightening torque

20—29 N·m {2.1—2.9 kgf·m, 15—21 ft·lbf}

AUTOMATIC TRANSAXLE

13. Assemble the parking rod component using the following procedure:

- (1) Align the parking rod component projection to the key hole of the manual plate component and assemble.

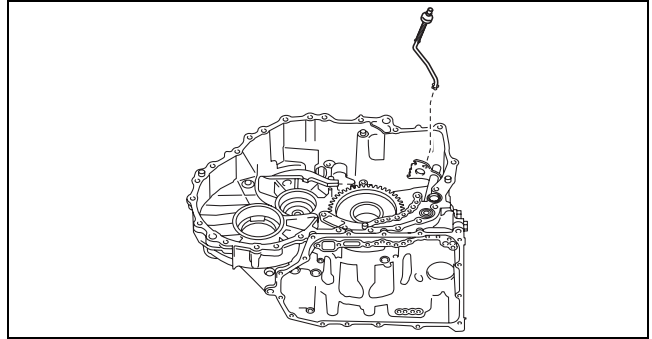

azzjw00000568

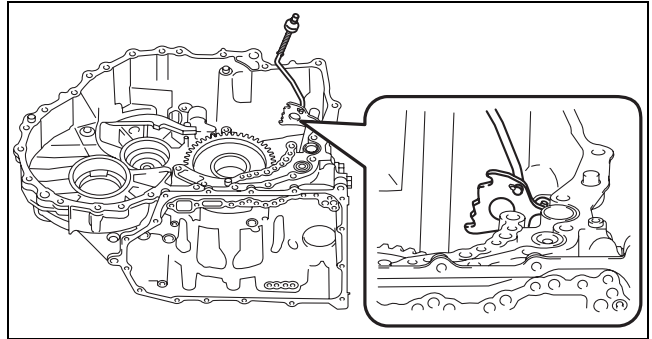

azzjw00000569

- (2) Rotate the parking rod component as shown in the figure.

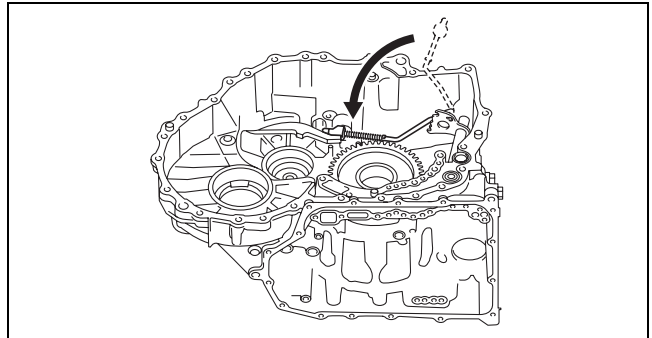

azzjw00000570

14. Assemble the parking pawl pin.

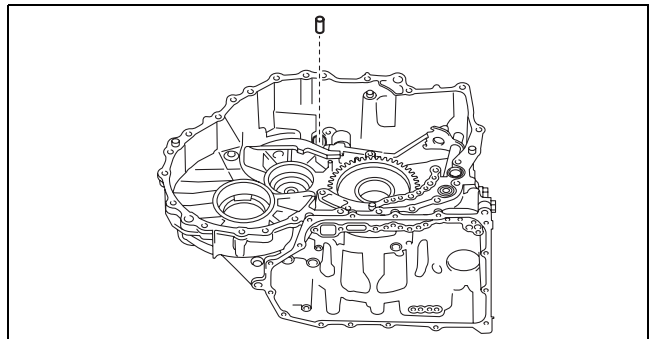

azzjw00000571

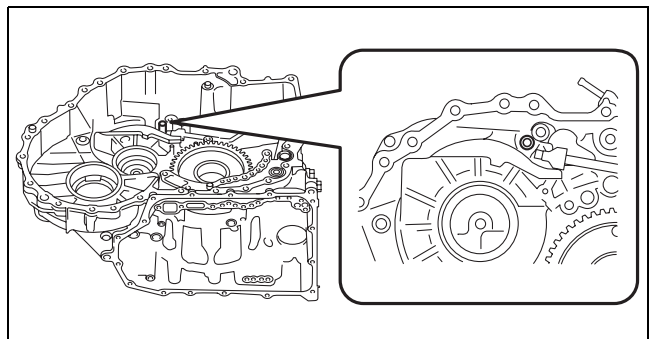

azzjw00000572

AUTOMATIC TRANSAXLE

15. Assemble the support actuator.

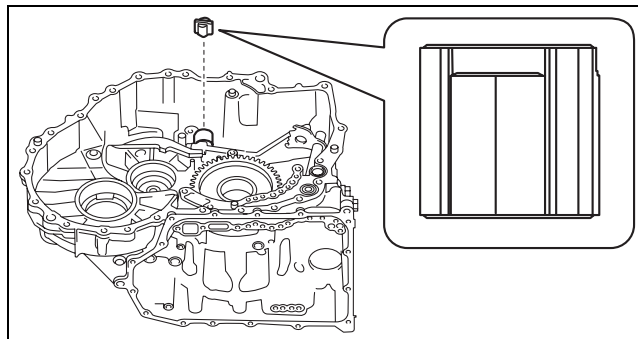

azzijw00000573

05-17

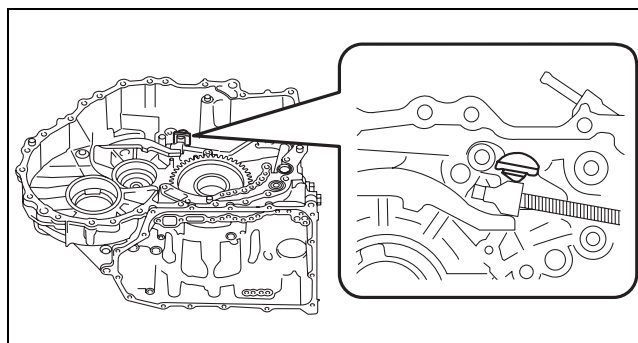

azzijw00000574

16. Assemble the detent bracket component using the following procedure:

- (1) Rotate the parking shift lever component (manual plate component) as shown in the figure.

A : Parking shift lever component

B : Manual plate component

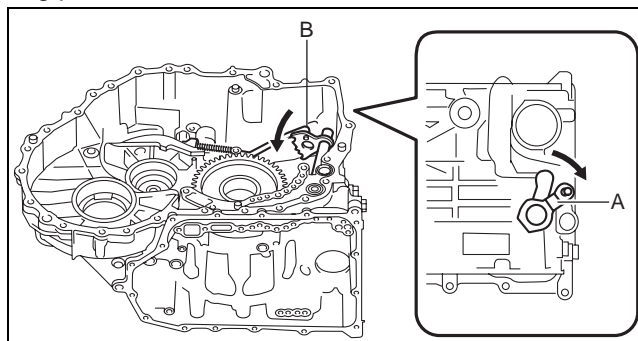

azzijw00000575

AUTOMATIC TRANSAXLE

(2) Assemble the detent bracket component using the procedure shown in the figure..

1	Detent bracket component
2	Bolt (M8×1.25 bolt, length to approx. 16 mm {0.63 in})

Caution

- When tightening bolts, verify that the detent bracket component does not interfere with the manual plate component to prevent damaging the part.

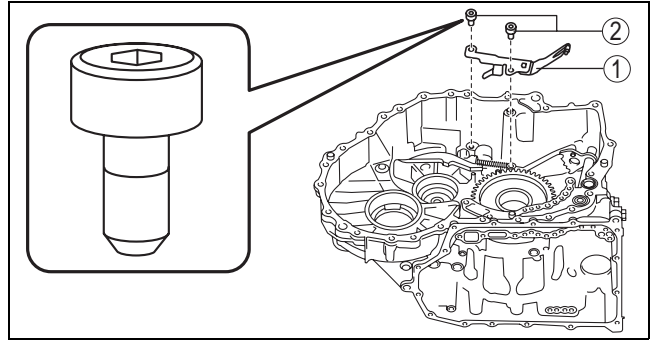

azzjiw00000576

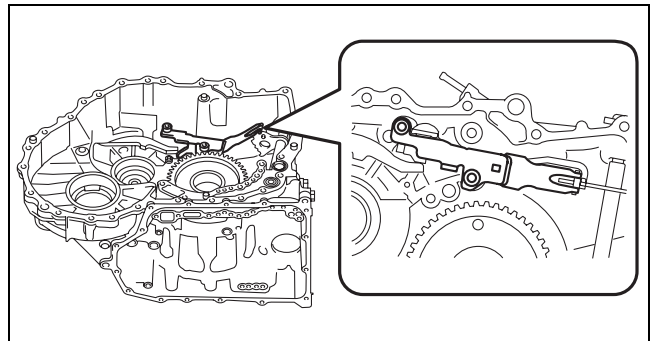

azzjiw00000577

A : Gap

Detent bracket component assembly bolt tightening torque
 11—14 N·m {113—142 kgf·cm,
 98—123 in·lbf}

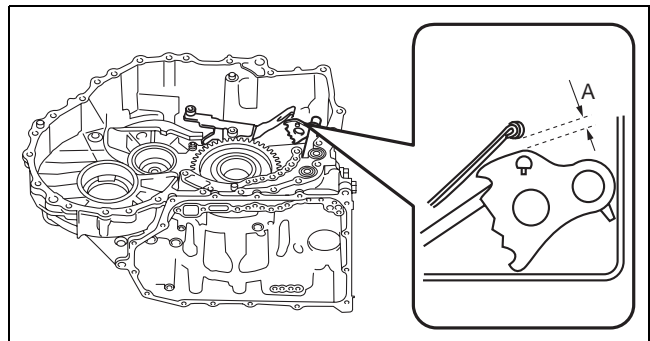

azzjiw00000578

(3) Rotate the parking shift lever component (manual plate component) as shown in the figure, and align the detent bracket component with the groove of the manual plate component.

- A : Parking shift lever component
- B : Manual plate component
- C : Detent bracket component

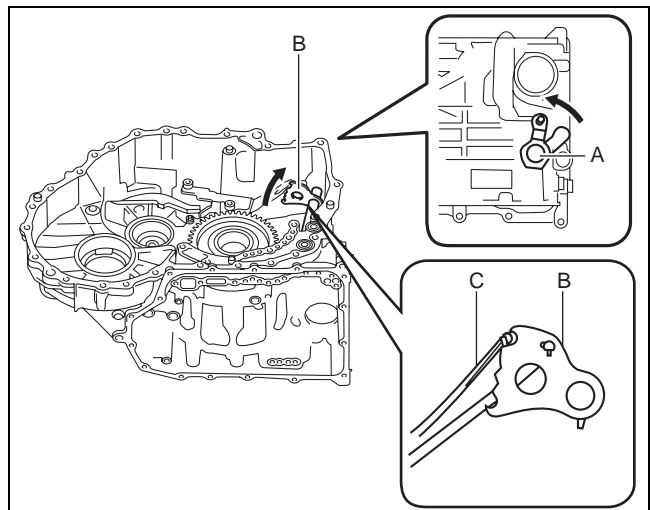

azzjiw00000579

AUTOMATIC TRANSAXLE

17. Assemble the pawl return springs using the following procedure:

(1) Assemble the pawl return springs.

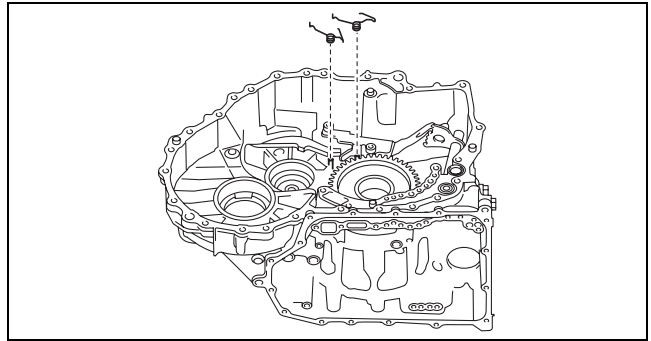

azzjw00000580

05-17

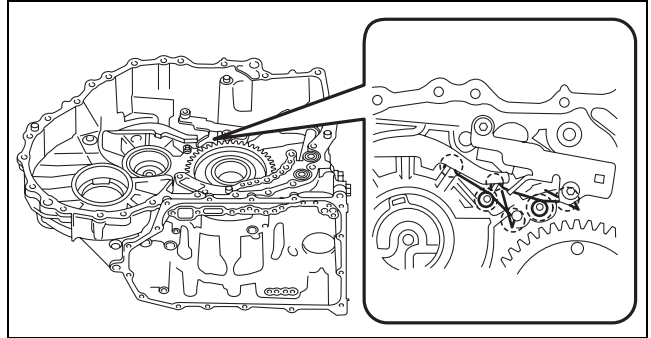

azzjw00000581

(2) To verify that the parts are securely assembled, move the parking pawl in the direction of (1) by hand, and verify that the parking pawl returns to its original position (direction (2)) when removing your hand.

A : Parking pawl

- If there is a malfunction, remove the pawl return springs and reassemble.

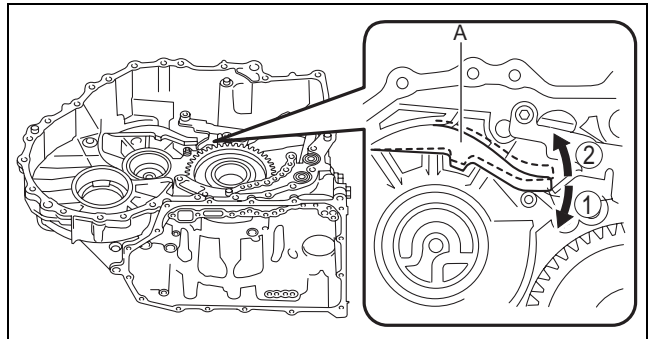

azzjw00000582

AUTOMATIC TRANSAXLE

18. Assemble the connector, new gaskets, the oil pipe, and new O-rings using the following procedure:

1	Oil pipe
2	O-ring (outer diameter approx. 11.6 mm {0.457 in}, thickness approx. 1.9 mm {0.075 in})
3	Connector
4	Gasket

Caution

- If a gasket is reused it could cause ATF leakage, therefore use a new gasket.
- If an O-ring is reused it could cause ATF leakage, therefore use a new O-ring.

- (1) Apply ATF (ATF FZ) to the new gaskets and new O-rings.
- (2) Assemble the connector, new gaskets, the oil pipe, and new O-rings using the following procedure:

1	Oil pipe
2	O-ring (outer diameter approx. 11.6 mm {0.457 in}, thickness approx. 1.9 mm {0.075 in})
3	Connector
4	Gasket

A : Long
B : Short

- (3) Assemble the parts assembled together in Step (2).

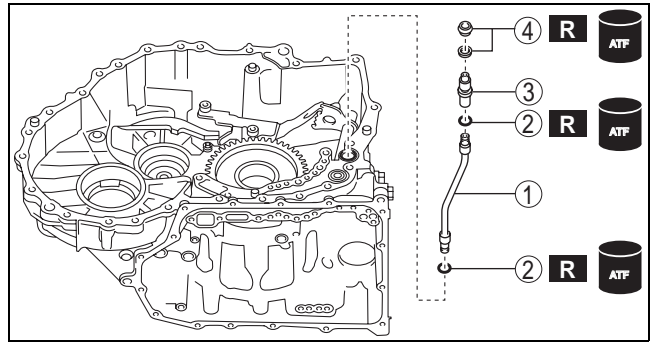

azzjw00000727

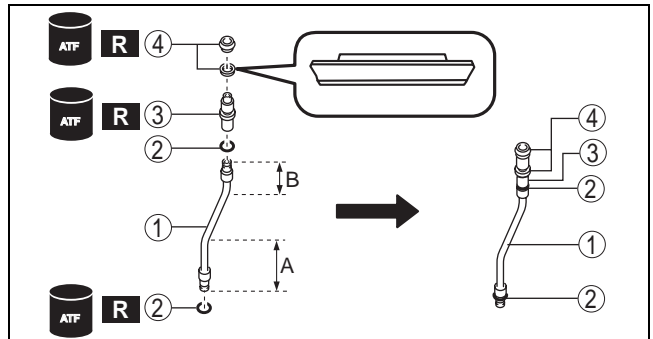

azzjw00000728

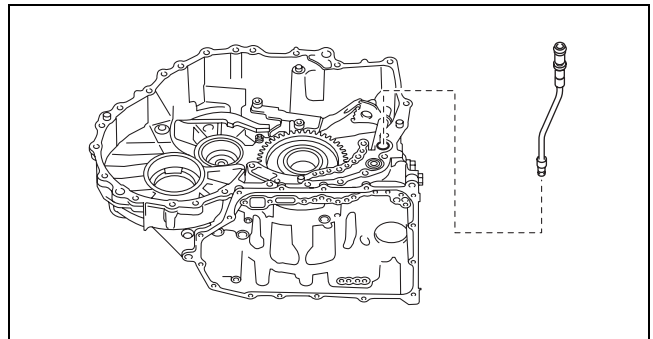

azzjw00000585

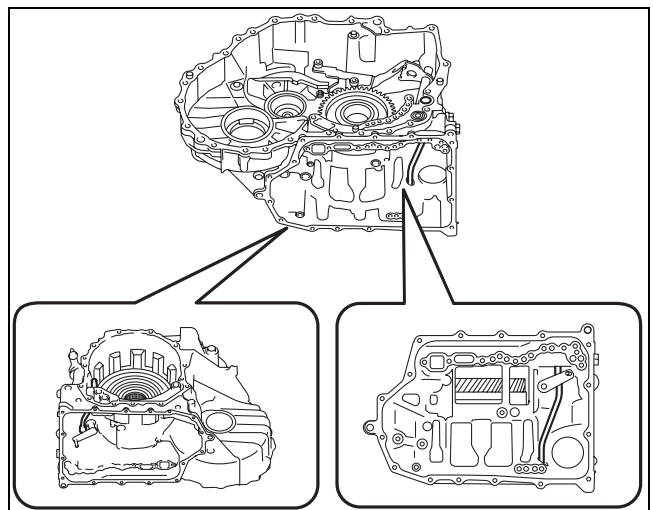

azzjw00000586

AUTOMATIC TRANSAXLE

19. Assemble the low and reverse brake piston using the following procedure:

- (1) Apply ATF (ATF FZ) to the lip of the low and reverse brake piston.
- (2) Assemble the low and reverse brake piston.

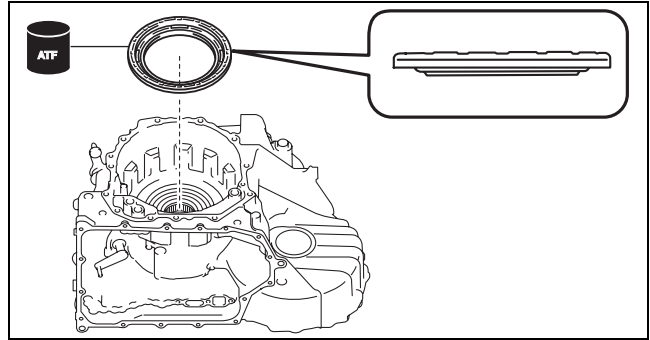

azzjjw0000587

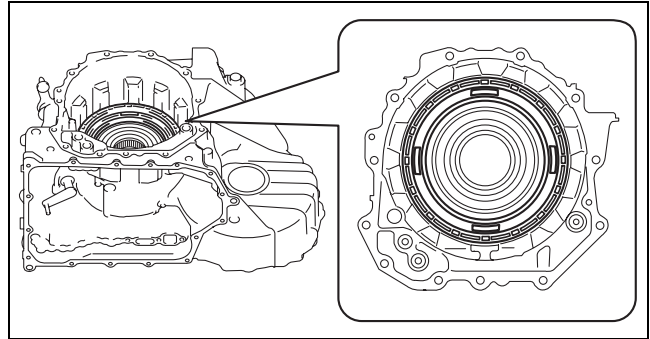

azzjjw0000588

20. Assemble the springs and retainer component.

Note

- Springs and retainer component size: Inner diameter approx. 152.3 mm {5.996 in}

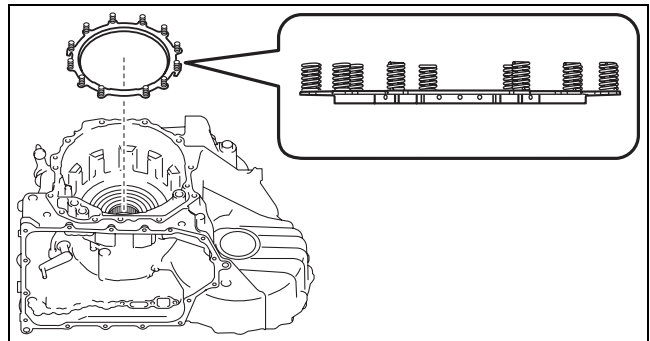

azzjjw0000589

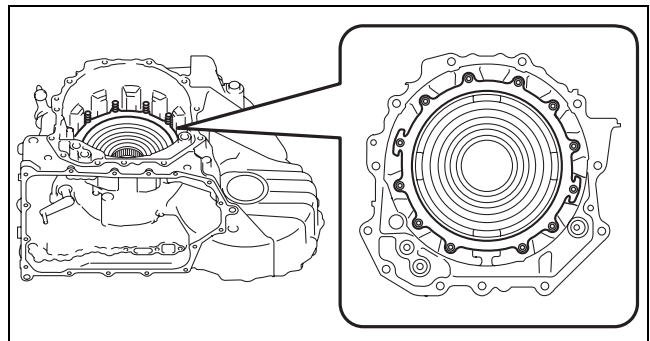

azzjjw0000590

AUTOMATIC TRANSAXLE

21. Assemble the drive plates and driven plates using the following procedure:

Note

- Drive plate size: Outer diameter approx. 174.1 mm {6.854 in}
- Driven plate size: Inner diameter approx. 149.6 mm {5.890 in}

(1) Apply ATF (ATF FZ) to the drive plates and driven plates.

Caution

- If the drive plate is replaced with a new one, immerse it in ATF (ATF FZ) for 2 hours or more to permeate the facing with ATF.

(2) Assemble the drive plates and driven plates.

A : Drive plate
B : Driven plate

Assembly order

Driven plate—drive plate—driven plate—drive
plate—driven plate—drive plate—driven
plate—drive plate

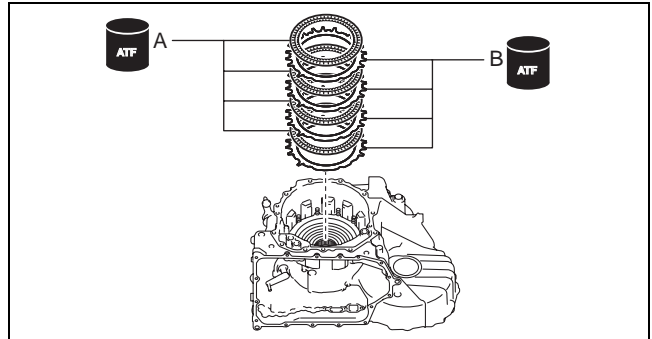

azzjw0000591

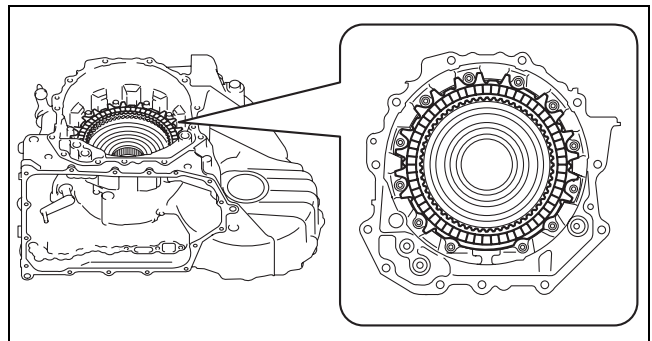

azzjw0000592

22. Assemble the one-way clutch.

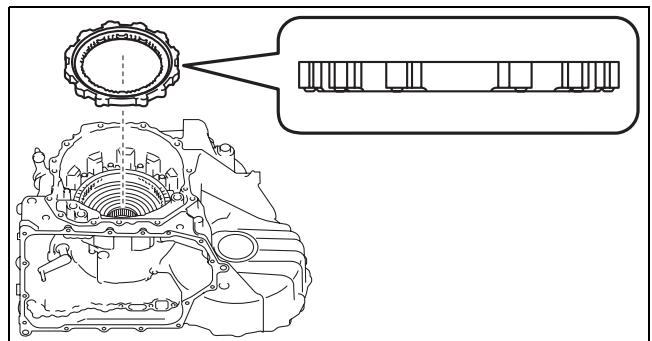

azzjw0000593

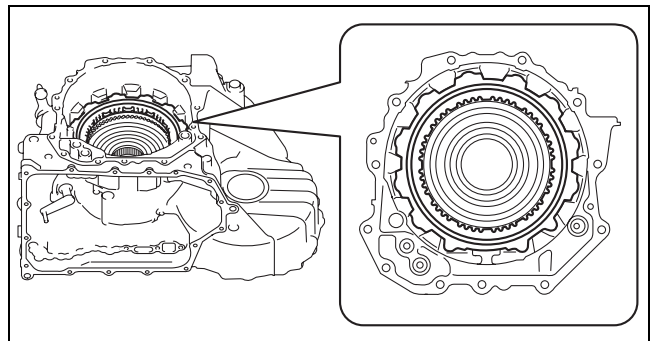

azzjw0000594

AUTOMATIC TRANSAXLE

23. Assemble the snap ring using the following procedure:

Note

- Snap ring size: Outer diameter approx. 198.0 mm {7.795 in}

(1) Measure the low and reverse brake clearance and select the appropriate snap ring. (See 05-17-353 LOW AND REVERSE BRAKE CLEARANCE MEASUREMENT/ADJUSTMENT.)

Note

- If the snap ring is assembled for the low and reverse brake clearance measurement/adjustment, the following snap ring assembly procedure is not necessary.

(2) Install the SSTs.

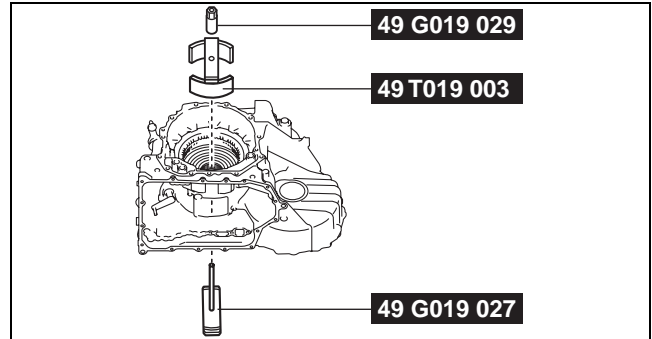

azzijw00000595

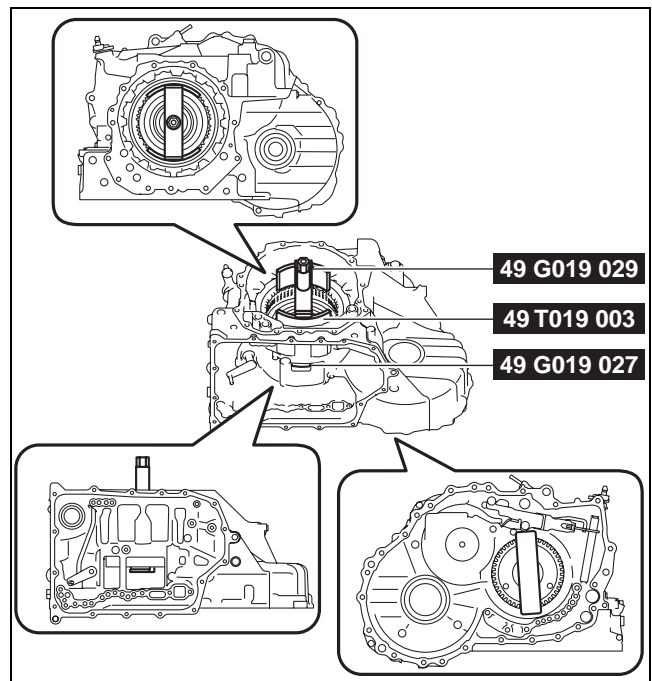

azzijw00000596

05-17

AUTOMATIC TRANSAXLE

(3) Tighten the SST (49 G019 029) until the snap ring groove of the transaxle case comes out.

A : Snap ring groove

Caution

- If the SST (49 G019 029) is tightened with excessive force, surrounding parts could be damaged. Stop tightening the SST when the snap ring groove of the transaxle case comes out.

Note

- Lock the SST (49 G019 027) against rotation using a flathead screwdriver and tighten the SST (49 G019 029).

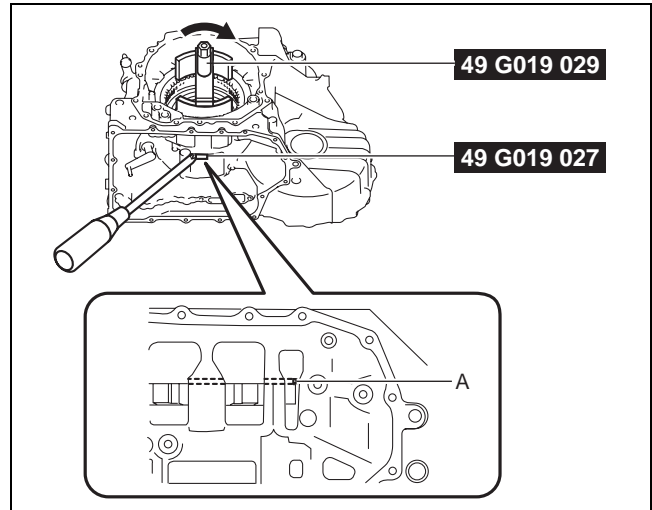

azzjiw00000597

(4) Assemble the selected snap ring in Step (1) to the position shown in the figure.

A : Selection

Caution

- Assemble the snap ring so that the end gap of the snap ring is in the area shown in the figure.
- After assembling the snap ring, verify that the snap ring is securely assembled to the bottom of the snap ring groove.

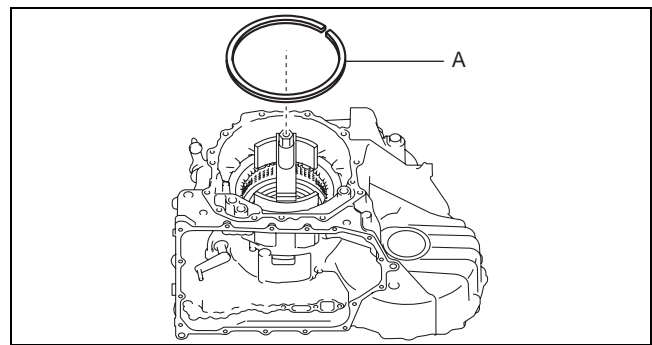

azzjiw00000598

A : End of snap ring assembly area

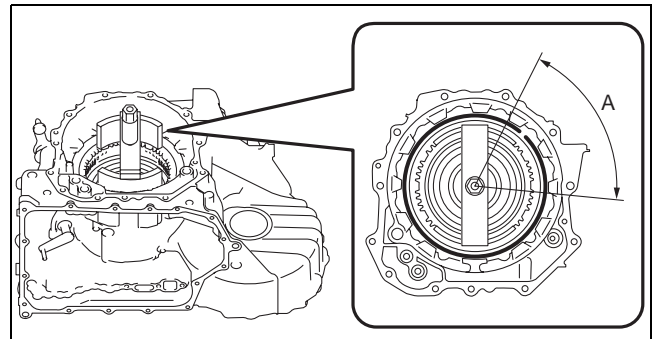

azzjiw00000599

AUTOMATIC TRANSAXLE

- (5) Loosen the SST (49 G019 029) and remove the SSTs.

Note

- Lock the SST (49 G019 027) against rotation using a flathead screwdriver and loosen the SST (49 G019 029).

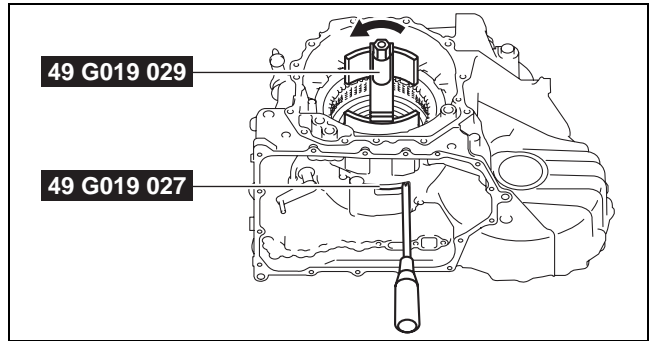

05-17

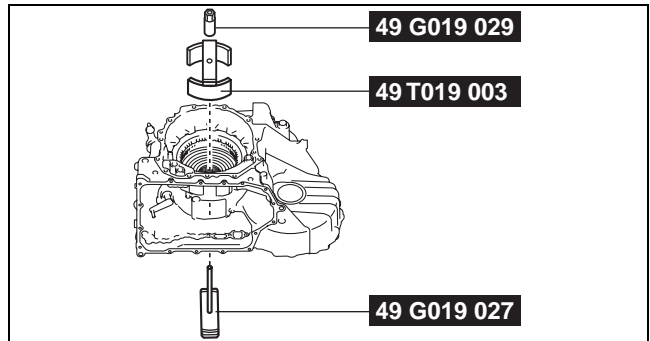

24. Apply ATF to the angular contact ball bearing using the following procedure:

Caution

- To reduce error during the secondary gear and output gear preload measurement, accurately perform the following procedure:

- (1) Apply ATF (ATF FZ) to the angular contact ball bearing ball.

A : ATF application area

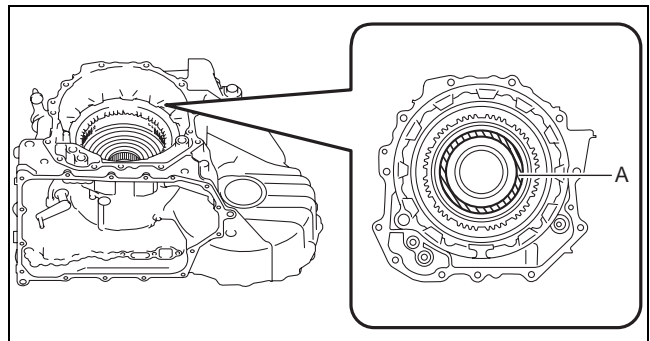

- (2) Rotate the primary gear and apply ATF to the angular contact ball bearing.

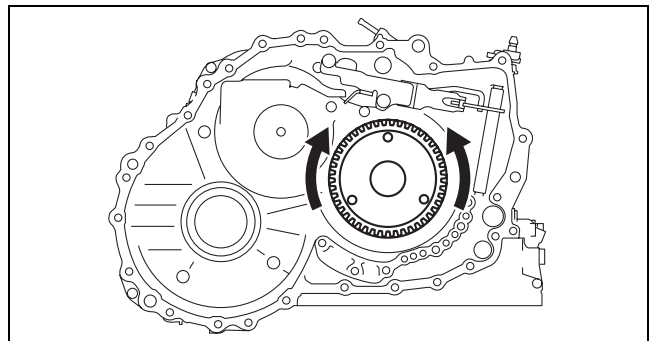

AUTOMATIC TRANSAXLE

25. Assemble the front planetary gear.

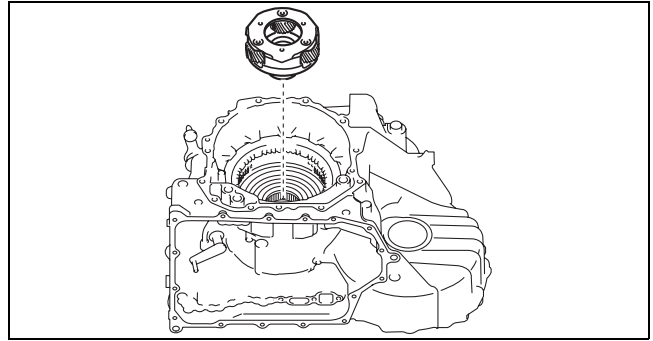

azzjiw00000603

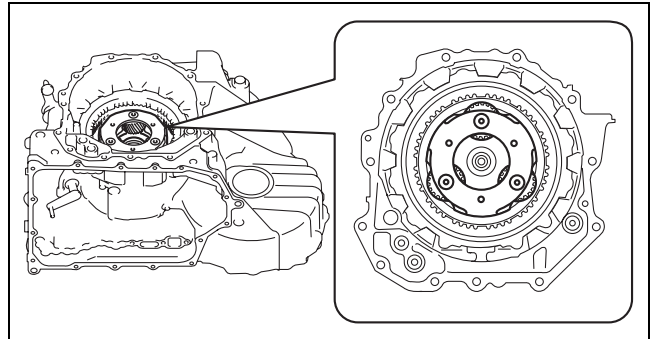

azzjiw00000604

26. Assemble a new locknut using the following procedure:

Caution

- Because the front planetary gear will drop if the end cover side is pointed downward before assembling the locknut, rotate the engine stand rotation handle, adjust so that the end cover side is situated sideways, and assemble the locknut.
- Always use a new locknut. If the removed locknut is reused, it may cause a transaxle malfunction.
- For tightening the locknut, 321—345 N·m {33—35 kgf·m, 237—254 ft·lbf} torque is required. For safety purposes, perform the procedure using two people, one tightens the locknut and the other supports the engine stand (transaxle case).

- (1) Rotate and adjust the rotation handle of the engine stand so that the end cover side is situated sideways.

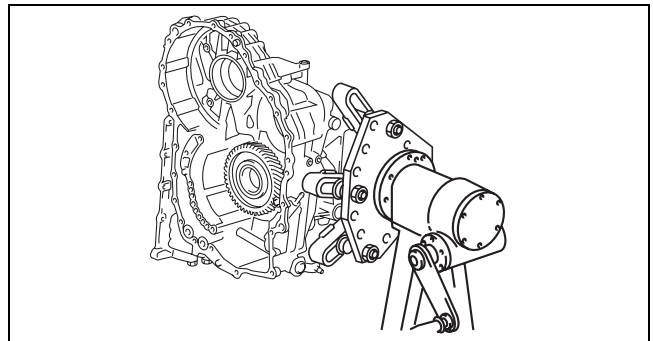

azzjiw00000605

- (2) Assemble and temporarily tighten a new locknut.

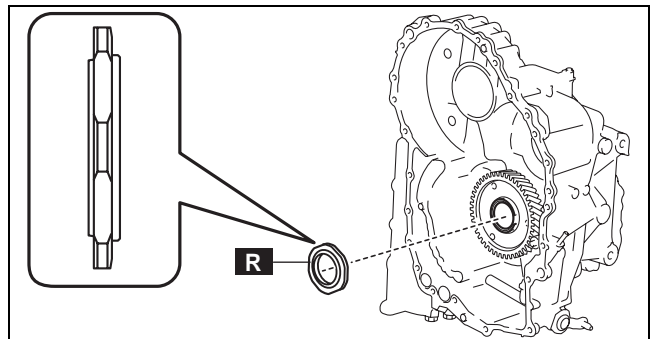

azzjiw00000606

AUTOMATIC TRANSAXLE

(3) Install the SSTs.

- A : Extension bar
B : Bolt supplied with SST (49 B019 029) or M8×1.25, length to 18 mm {0.71 in}

Note

- Engage the three projections of the SST (49 B019 028) to the three holes of the primary gear.
- When installing the SST (49 B019 029), use the bolts supplied with the SST (49 B019 029), or M8×1.25 bolt, length to 18 mm {0.71 in}.

- A : Extension bar
B : Bolt supplied with SST (49 B019 029) or M8×1.25, length to 18 mm {0.71 in}

SST installation bolt tightening torque

19—25 N·m {2.0—2.5 kgf·m, 15—18 ft·lbf}

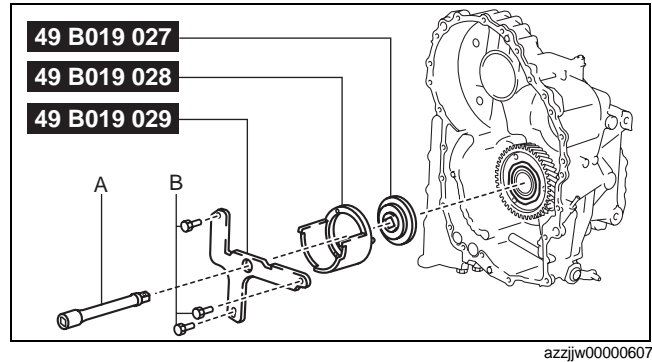

05-17

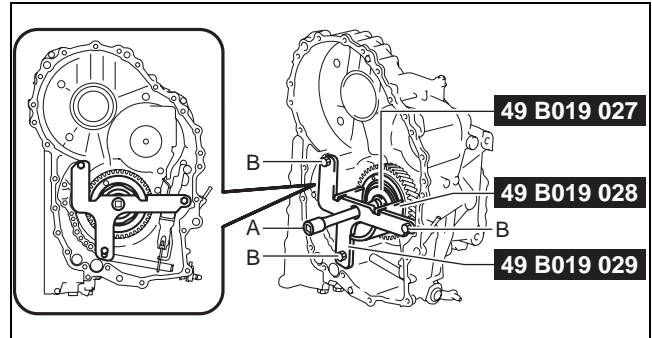

(4) Tighten the locknut.

Caution

- For tightening the locknut, 321—345 N·m {33—35 kgf·m, 237—254 ft·lbf} torque is required. For safety purposes, perform the procedure using two people, one tightens the locknut and the other supports the engine stand (transaxle case).

Tightening torque

321—345 N·m {33—35 kgf·m, 237—254 ft·lbf}

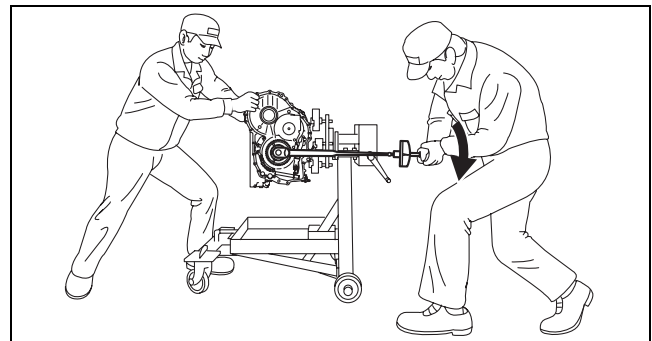

(5) Remove the SSTs.

- A : Extension bar
B : Bolt supplied with SST (49 B019 029) or M8×1.25, length to 18 mm {0.71 in}

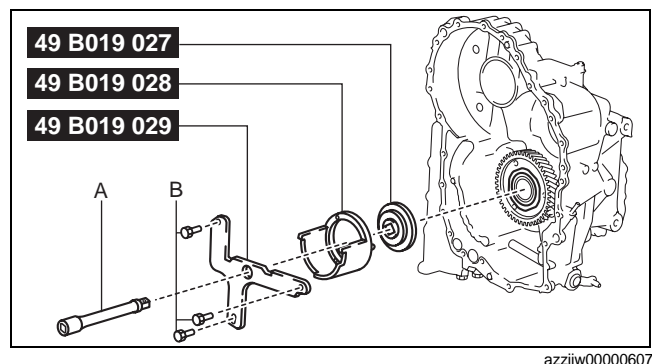

AUTOMATIC TRANSAXLE

(6) Crimp the locknut at the two positions shown in the figure using a pin punch.

Note

- Crimp the locknut flange until it contacts the whole groove of the front planetary gear end.

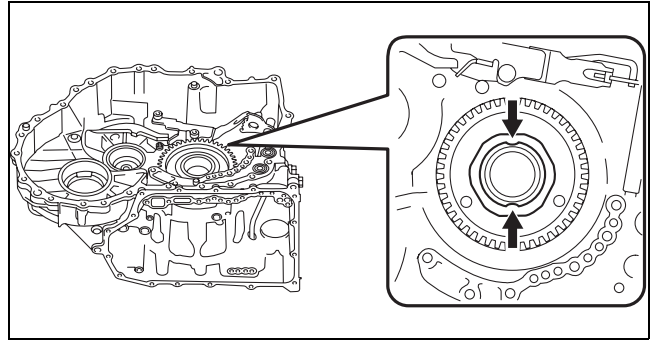

azzjiw00000610

- A : Locknut flange
- B : Front planetary gear end

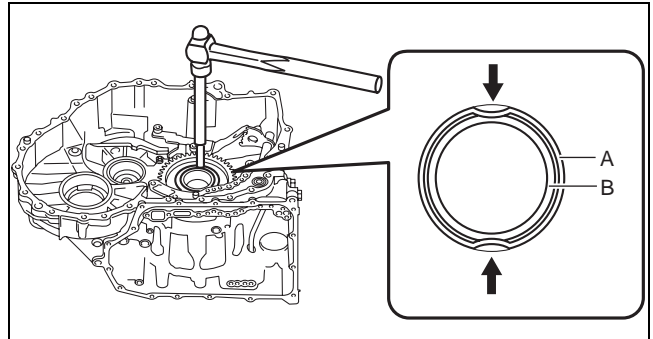

azzjiw00000611

27. Assemble the bearing race using the following procedure:

Note

- Bearing race size: Outer diameter approx. 70 mm {2.8 in}

- (1) Apply ATF (ATF FZ) to the engagement area of the bearing race and transaxle case.
- (2) Assemble the bearing race using the SSTs.

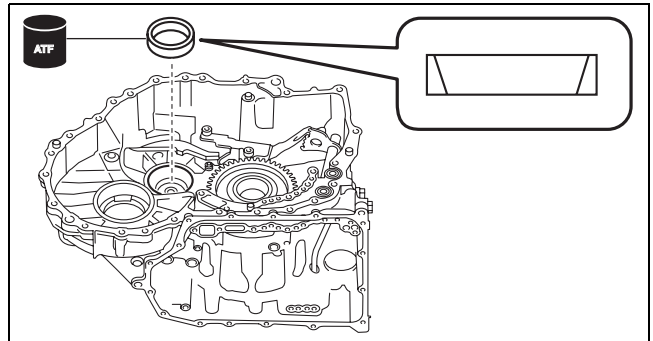

azzjiw00000612

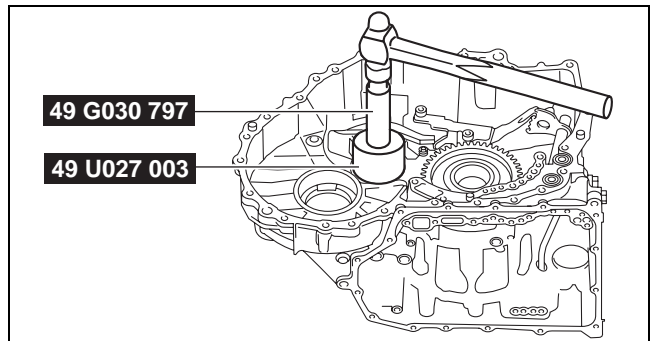

azzjiw00000613

AUTOMATIC TRANSAXLE

28. Assemble the bearing race and a new shim using the following procedure:

Caution

- Always use a new shim. If a deformed shim is reused, it may cause a transaxle malfunction.

- (1) Apply ATF (ATF FZ) to the engagement area of the bearing race and transaxle case.
- (2) Using the SST, assemble the bearing race and a new shim using the following procedure:

1	Shim (outer diameter approx. 79 mm {3.1 in}, thickness approx. 0.5 mm {0.02 in})
2	Bearing race (outer diameter approx. 80 mm {3.1 in})

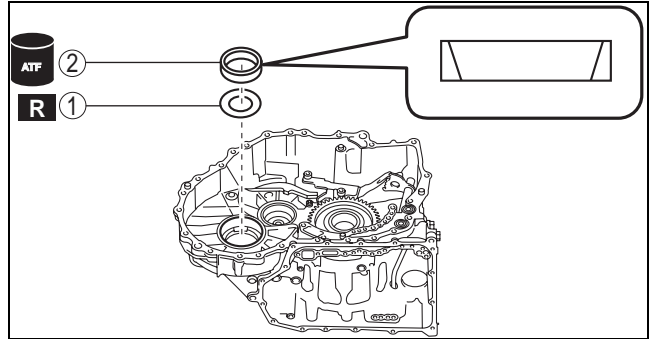

05-17

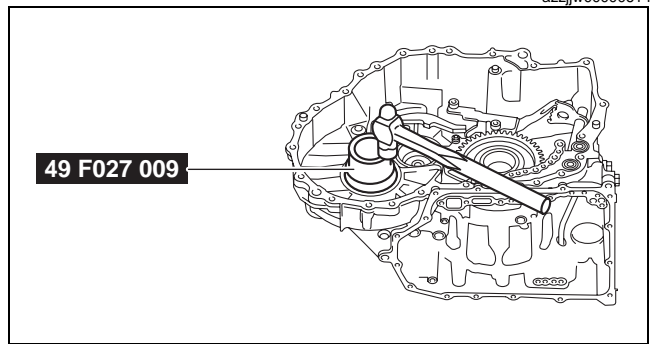

azzijw00000614
azzijw00000615

29. Assemble a new oil seal using the following procedure:

Caution

- If an oil seal is reused it could cause ATF leakage, therefore use a new oil seal.

Note

- Oil seal size: Outer diameter approx. 63 mm {2.5 in}

- (1) Apply ATF (ATF FZ) to the engagement area of the new oil seal and transaxle case.
- (2) Apply ATF (ATF FZ) to the lip of the new oil seal.
- (3) Assemble the new oil seal to the position shown in the figure using the SSTs.

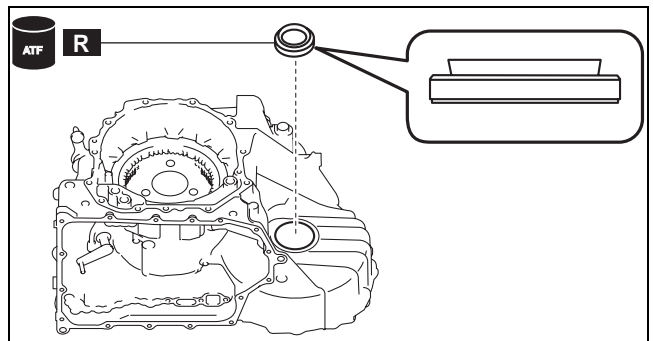

azzijw00000616

A : -0.8—0.5 mm {-0.03—0.01 in}

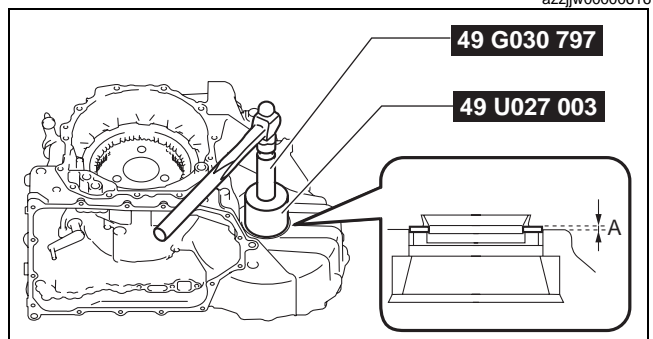

azzijw00000617

AUTOMATIC TRANSAXLE

30. Press the angular contact ball bearing to the primary gear side using the following procedure:

Caution

- To reduce error during the total end play measurement, accurately perform the following procedure:

Note

- Work overview
 - There is a gap between the snap ring groove of the angular contact ball bearing, snap ring, and the snap ring groove of the transaxle case because the angular contact ball bearing is fixed to the transaxle case by the snap ring. The gap causes an error during the total end play measurement. Using the following procedure, the error during the total end play measurement is reduced by moving the angular contact ball bearing to the standard position.

- A : Transaxle case
B : Snap ring
C : Angular contact ball bearing

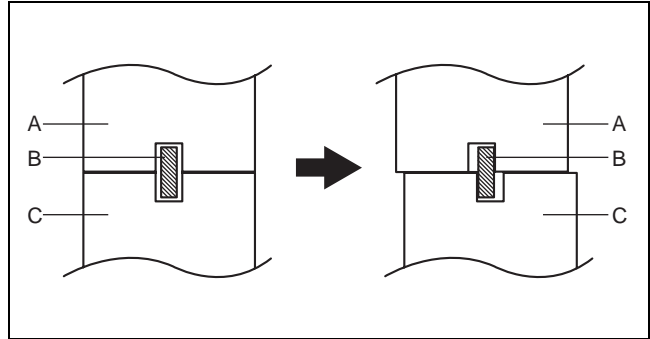

azzjiw00000618

- (1) Press the angular contact ball bearing to the primary gear side using the SSTs.

Caution

- Do not strongly tap the SST contacting the front planetary gear to prevent damage to the parts.

Note

- Lightly tap the SST contacting the front planetary gear 2—3 times using a plastic hammer and press the angular contact ball bearing to the primary gear side.

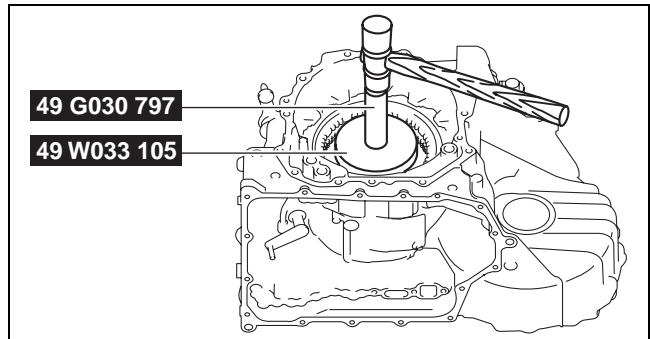

azzjiw00000619

AUTOMATIC TRANSAXLE

31. Assemble the baffle plate using the procedure shown in the figure..

1	Baffle plate
2	Bolt (M6×1.0 bolt, length to approx. 15 mm {0.59 in}*)

* : Length without spring washer is indicated due to bolt with spring washer. Length with spring washer is approx. 13 mm {0.51 in}.

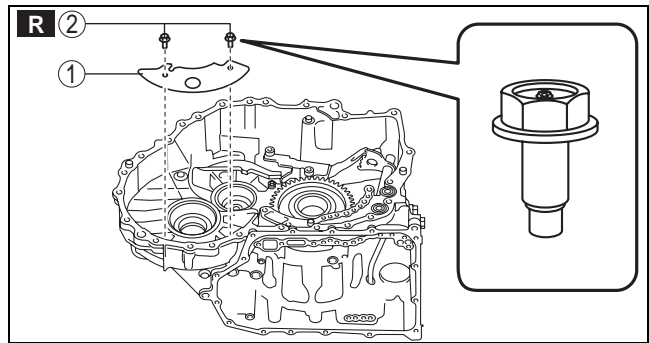

azzjw00000620

05-17

Caution

- The bolts for the baffle plate assembly are applied with thread-locking compound. If the bolts are reused it could loosen the bolts, therefore use new bolts.

Baffle plate assembly bolt tightening torque
8—10 N·m {82—101 kgf·cm, 71—88 in·lbf}

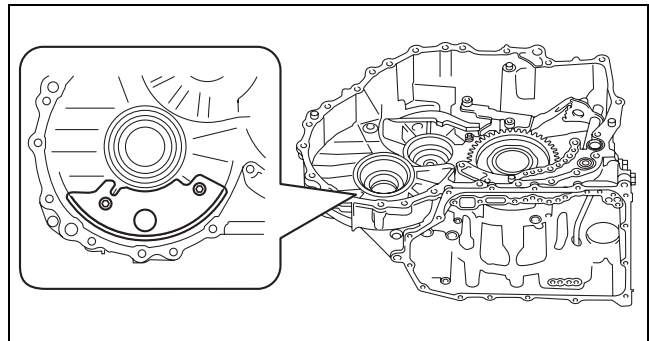

azzjw00000621

32. Assemble the accessories included in the converter housing using the following procedure:

(1) Assemble the bearing race and a new shim using the following procedure:

Caution

- Always use a new shim. If a deformed shim is reused, it may cause a transaxle malfunction.

1) Measure the secondary gear and output gear preload and select the appropriate new shim. (See 05-17-364 SECONDARY GEAR AND OUTPUT GEAR PRELOAD MEASUREMENT/ADJUSTMENT.)

Note

- If the bearing race and a new shim are assembled for the secondary gear and output gear preload measurement/adjustment, the following assembly procedure for the bearing race and a new shim is not necessary.

2) Apply ATF (ATF FZ) to the engagement area of the bearing race and converter housing.

AUTOMATIC TRANSAXLE

- 3) Using the SST, assemble the bearing race and the selected new shim in Step 1) using the following procedure:

1	Shim (outer diameter approx. 74 mm {2.9 in}) (selection)
2	Bearing race (outer diameter approx. 75 mm {3.0 in})

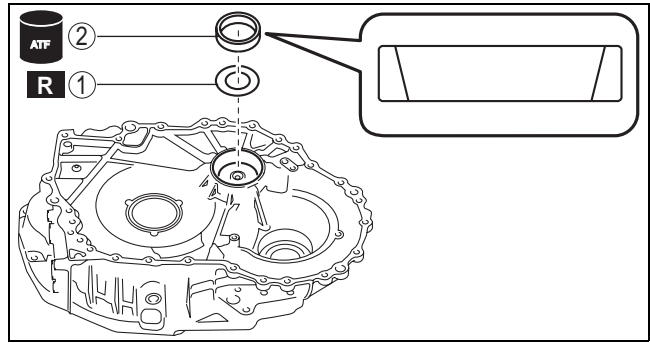

azzjiw00000622

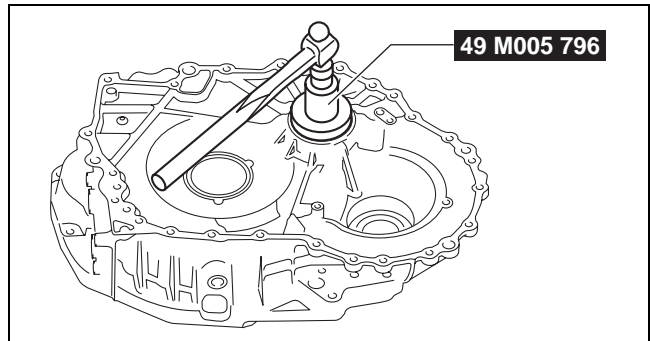

azzjiw00000733

- (2) Assemble the bearing race and a new shim using the following procedure:

Caution

- **Always use a new shim. If a deformed shim is reused, it may cause a transaxle malfunction.**

- 1) Measure the ring gear and differential preload and select the appropriate new shim. (See 05-17-375 RING GEAR AND DIFFERENTIAL PRELOAD MEASUREMENT/ADJUSTMENT.)

Note

- If the bearing race and a new shim are assembled for the ring gear and differential preload measurement/adjustment, the following assembly procedure for the bearing race and a new shim is not necessary.
- 2) Apply ATF (ATF FZ) to the engagement area of the bearing race and converter housing.

AUTOMATIC TRANSAXLE

3) Using the SST, assemble the bearing race and the selected new shim in Step 1) using the following procedure:

1	Shim (outer diameter approx. 79 mm {3.1 in}) (selection)
2	Bearing race (outer diameter approx. 80 mm {3.1 in})

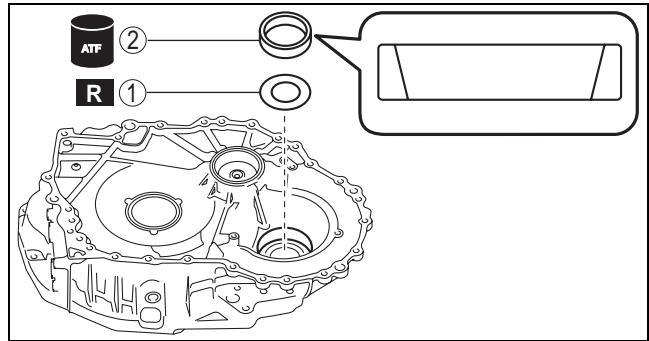

azzjw00000624

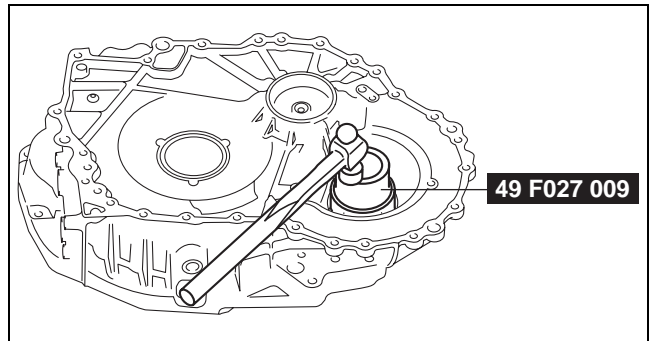

azzjw00000625

(3) Assemble a new oil seal using the following procedure:

Caution

- If an oil seal is reused it could cause ATF leakage, therefore use a new oil seal.

Note

- Oil seal size: Outer diameter approx. 65 mm {2.6 in}

- 1) Apply ATF (ATF FZ) to the engagement area of the new oil seal and converter housing.
- 2) Apply ATF (ATF FZ) to the lip of the new oil seal.
- 3) Assemble the new oil seal to the position shown in the figure using the SSTs.

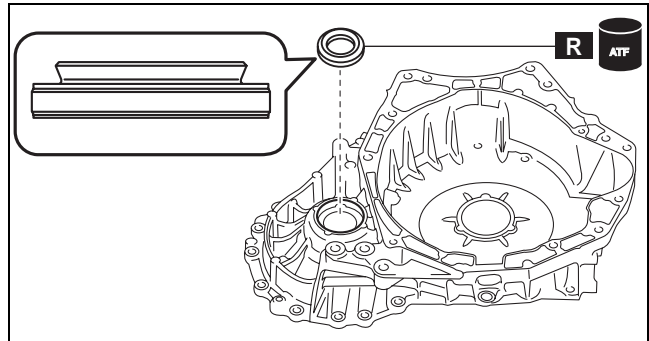

azzjw00000626

A : -0.8—0.5 mm {-0.03—0.01 in}

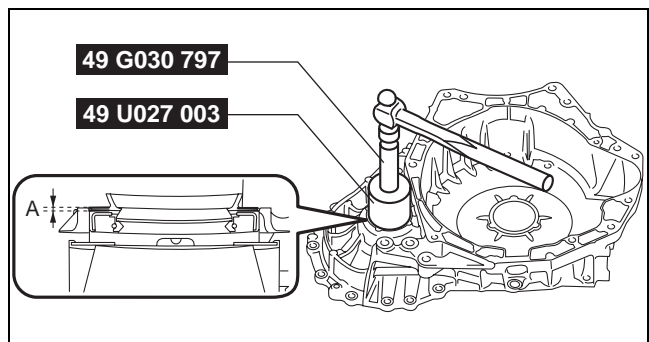

azzjw00000627

AUTOMATIC TRANSAXLE

- 4) Assemble the baffle plate using the procedure shown in the figure.

1	Baffle plate
2	Bolt (M6×1.0 bolt, length to approx. 14 mm {0.55 in})

Baffle plate assembly bolt tightening torque
8—10 N·m {82—101 kgf·cm, 71—88 in·lbf}

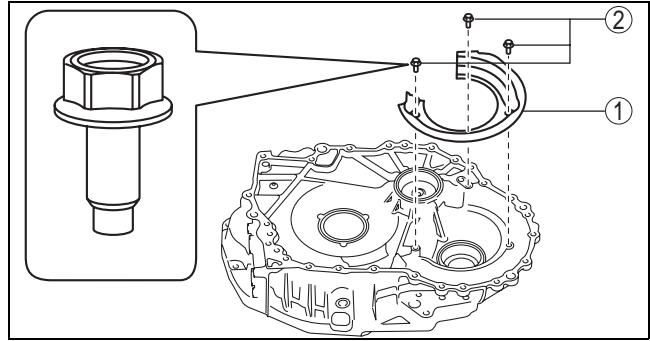

azzjw00000628

33. Assemble the secondary gear and output gear.

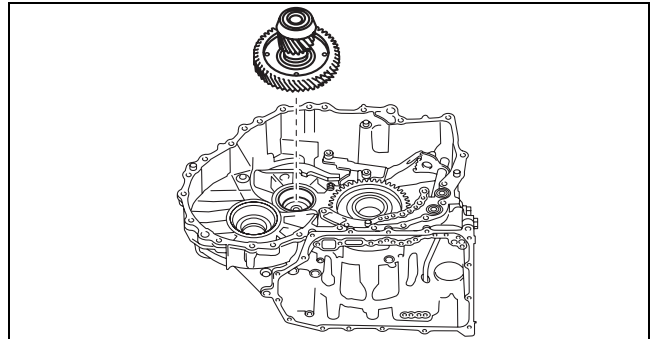

azzjw00000629

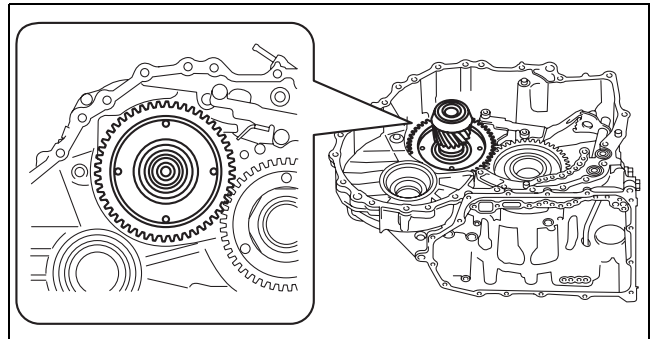

azzjw00000630

34. Assemble the oil pipe.

Caution

- Do not assemble the oil pipe using a tool such as a hammer to prevent damaging the part. For the oil pipe assembly, it is better to only use your hands to put the oil pipe into the output gear.

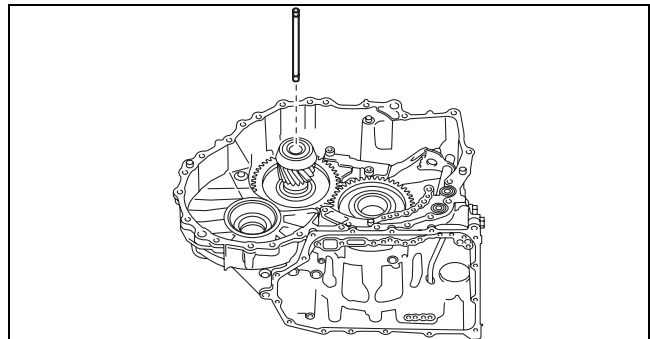

azzjw00000631

AUTOMATIC TRANSAXLE

35. Assemble the ring gear and differential.

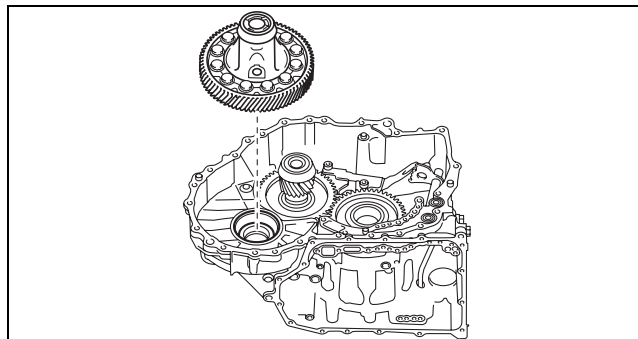

azzjw00000632

05-17

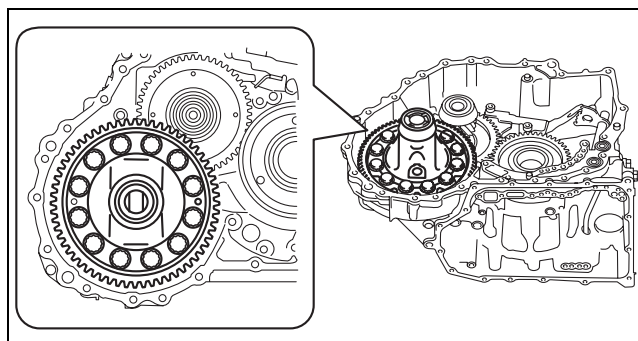

azzjw00000633

36. Assemble the thrust needle bearing.

Note

- Thrust needle bearing size: Outer diameter approx. 80.3 mm {3.16 in}

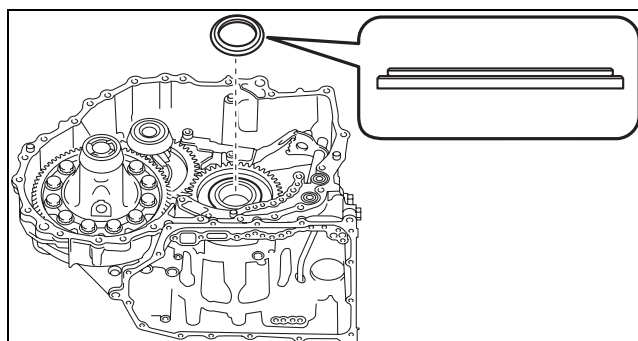

azzjw00000634

AUTOMATIC TRANSAXLE

37. Assemble a new D-ring and new seal rings to the turbine shaft using the following procedure:

Caution

- If a D-ring is reused it could cause ATF leakage, therefore use a new D-ring.
- If a seal ring is reused it could cause ATF leakage, therefore use a new seal ring.

- (1) Apply ATF (ATF FZ) to the new D-ring and new seal rings.
- (2) Assemble the new D-ring and new seal rings to the turbine shaft using the procedure shown in the figure:

1	Seal ring (outer diameter approx. 24.4 mm {0.961 in}, thickness approx. 1.5 mm {0.059 in})
2	D-ring (outer diameter approx. 16.4 mm {0.646 in}, thickness approx. 2.4 mm {0.094 in})

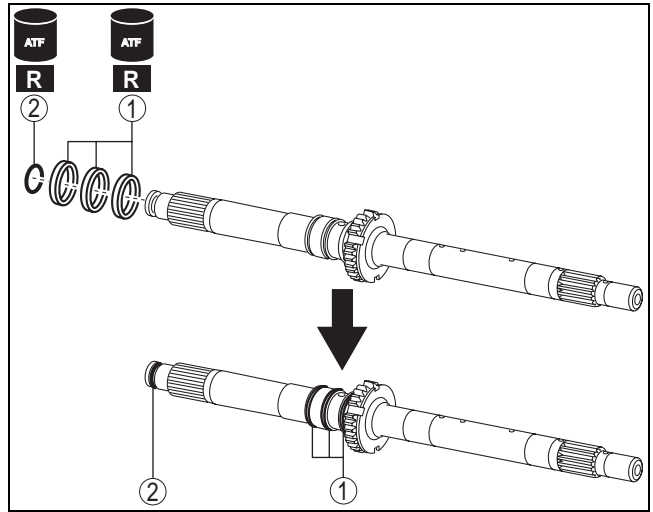

azzjiw00000635

38. Assemble together the clutch component, turbine shaft, high clutch hub, low clutch hub, and thrust needle bearing using the following procedure:

- (1) Assemble the parts using the procedure shown in the figure:

1	Clutch component
2	Turbine shaft
3	Thrust needle bearing (outer diameter approx. 37.3 mm {1.47 in})
4	High clutch hub
5	Thrust needle bearing (outer diameter approx. 51.3 mm {2.02 in})
6	Low clutch hub

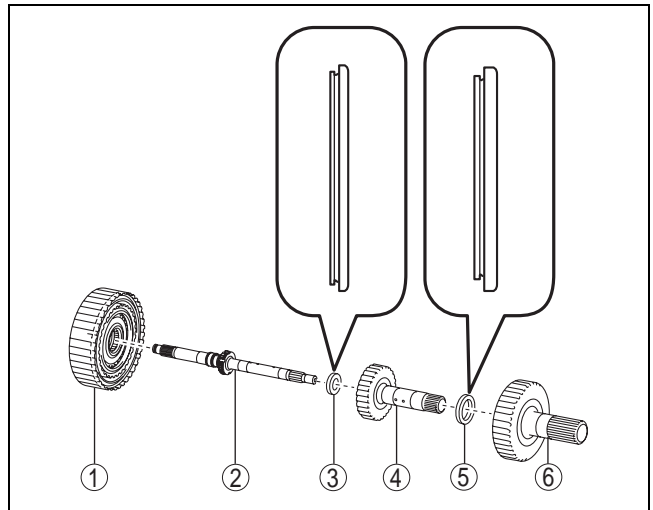

azzjiw00001563

Note

- For the high clutch hub and low clutch hub assembly, assembly is easier if the work is performed using the following procedure:

— High clutch hub

1. Place the assembled parts on the workbench with the clutch component situated sideways.

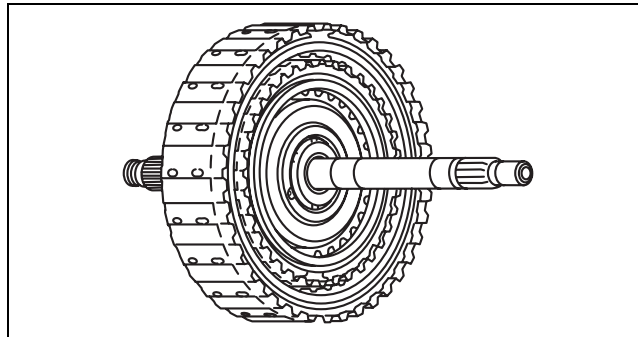

azzjjw00000638

2. While rotating the high clutch hub, engage the splines of each of the high clutch drive plates one by one, and assemble.

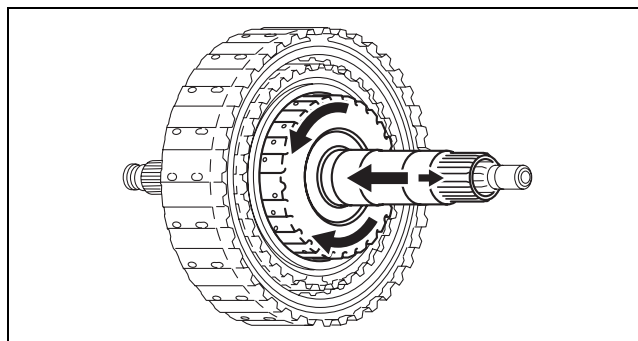

azzjjw00000639

— Low clutch hub

1. Place the assembled parts on the workbench with the clutch component situated sideways.

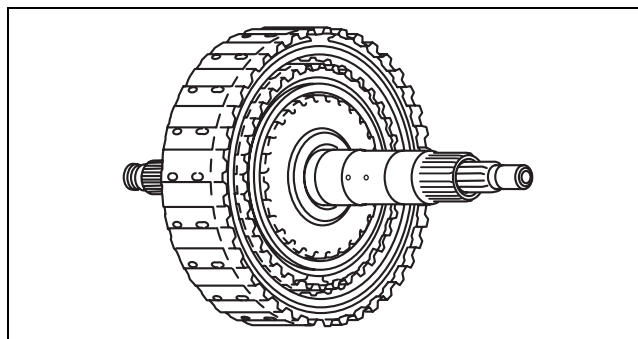

azzjjw00000640

2. While rotating the low clutch hub, engage the splines of each of the low clutch drive plates one by one, and assemble.

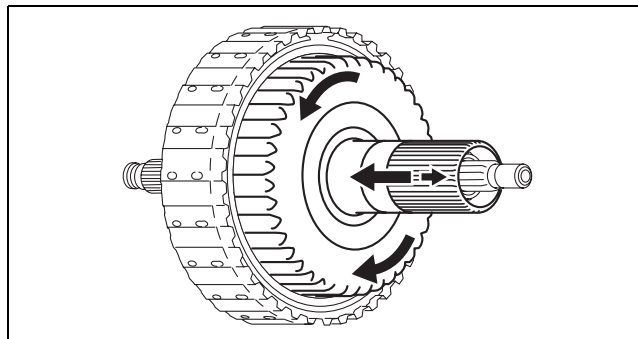

azzjjw00000641

AUTOMATIC TRANSAXLE

- (2) To verify that the parts are securely assembled together, measure the distance shown in the figure.

Note

- Recommended measuring instrument:
Vernier caliper

Specification

63.9—66.0 mm {2.52—2.59 in}

- If not within the specification, disassemble the assembled parts and reassemble.

39. Assemble the parts which were assembled together in Step 38 using the following procedure:

- (1) Assemble the parts assembled together in Step 38.

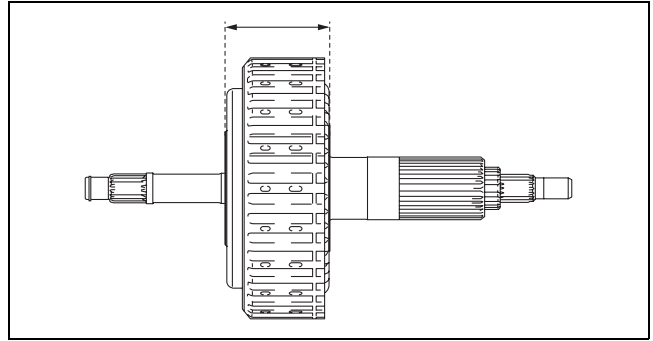

azzjiw00000637

- (2) To verify that the parts are securely assembled, measure the distance shown in the figure.

- A : Transaxle case end (alignment surface with converter housing)
B : Clutch component end

Note

- Recommended measuring instrument:
Depth gauge, straight edge ruler

Specification

11.6—14.8 mm {0.457—0.582 in}

- If not within the specification, remove the parts and perform re-assembly from Step 38.

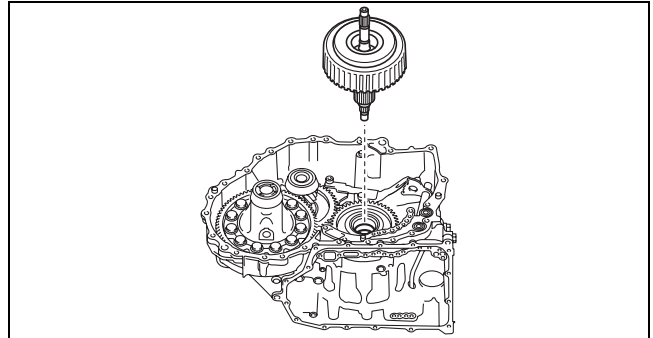

azzjiw00000642

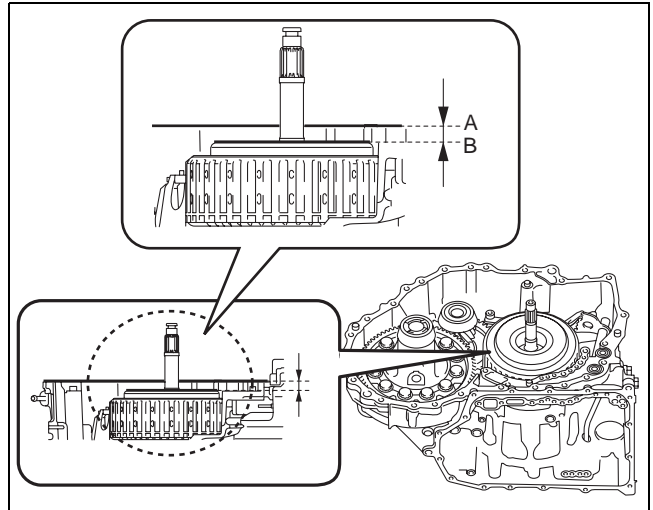

azzjiw00001564

Note

- Measurement method

- 1) Set two straight edge rulers along the alignment surface of the transaxle case with the converter housing as shown in the figure.

- A : Straight edge ruler

- 2) Measure the positions (2 locations) shown in the figure using a depth gauge and calculate the average value.
- 3) Subtract the thickness of the straight edge ruler from the average value.

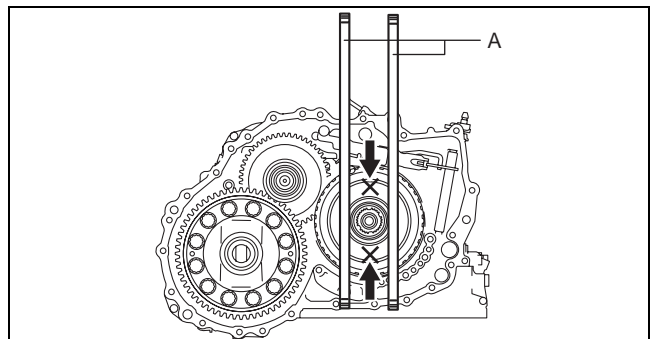

azzjiw00000644

AUTOMATIC TRANSAXLE

40. Assemble the thrust needle bearing.

Note

- Thrust needle bearing size: Outer diameter approx. 72.7 mm {2.86 in}

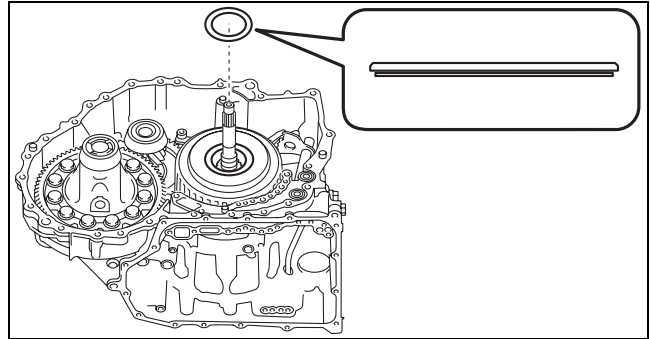

azzjjw00000645

05-17

41. Assemble the oil pump using the following procedure:

1	Oil pump
2	7 bolts (M8×1.25 bolt, length to approx. 31 mm {1.2 in})

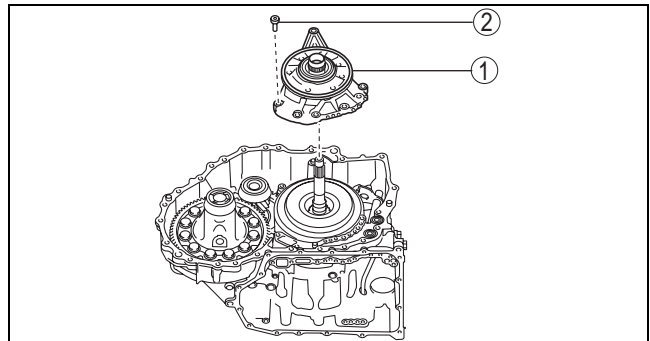

azzjjw00000646

(1) Assemble the oil pump.

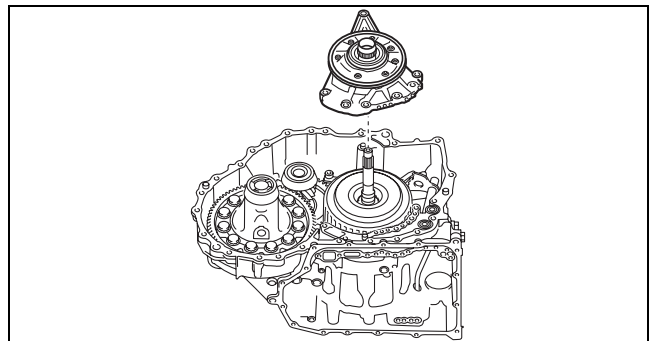

azzjjw00000647

(2) Assemble and tighten the bolts shown in the figure.

Note

- Bolt size: M8×1.25 bolt, length to approx. 31 mm {1.2 in}

Tightening torque

19—25 N·m {2.0—2.5 kgf·m, 15—18 ft·lbf}

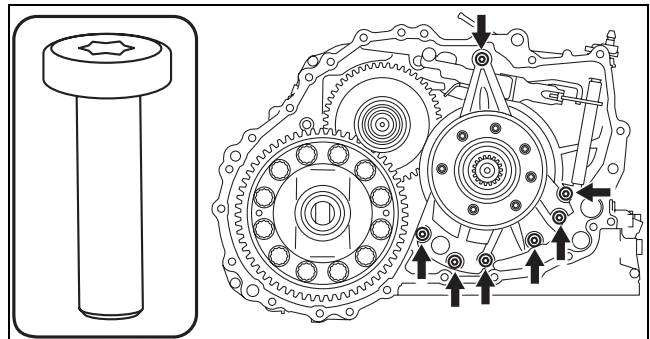

azzjjw00000648

AUTOMATIC TRANSAXLE

42. Assemble the baffle plate.

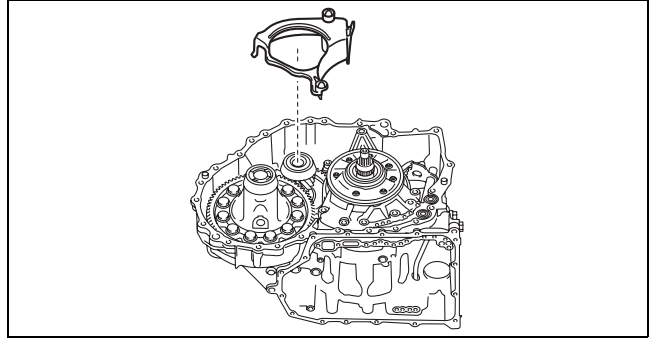

azzjiw00000649

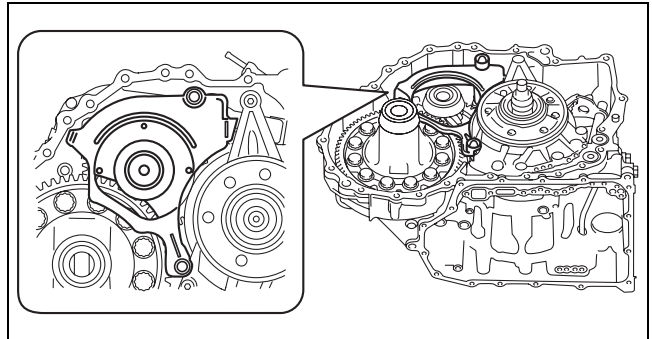

azzjiw00000650

43. Assemble the converter housing using the following procedure:

1	O-ring (outer diameter approx. 15.6 mm {0.614 in}, thickness approx. 2.4 mm {0.094 in})
2	O-ring (outer diameter approx. 73.3 mm {2.89 in}, thickness approx. 3.0 mm {0.12 in})
3	Converter housing
4	24 bolts * (M8×1.25 bolt, length to approx. 28 mm {1.1 in})

* : Of the 24 bolts, 6 are applied with sealant

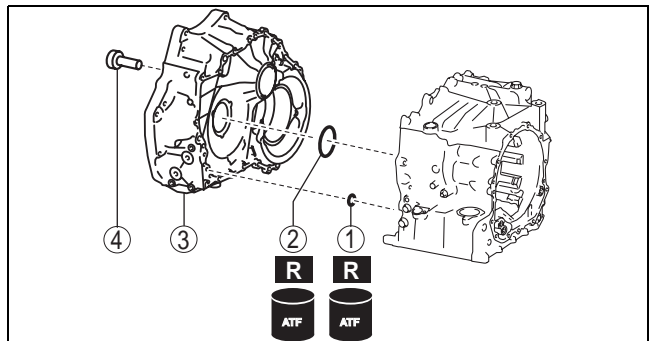

azzjiw00000651

AUTOMATIC TRANSAXLE

(1) Assemble new O-rings using the following procedure:

Caution

- If an O-ring is reused it could cause ATF leakage, therefore use a new O-ring.

- 1) Apply ATF (ATF FZ) to the new O-rings.
- 2) Assemble the new O-rings in the order shown in the figure.

1	O-ring (outer diameter approx. 15.6 mm {0.614 in}, thickness approx. 2.4 mm {0.094 in})
2	O-ring (outer diameter approx. 73.3 mm {2.89 in}, thickness approx. 3.0 mm {0.12 in})

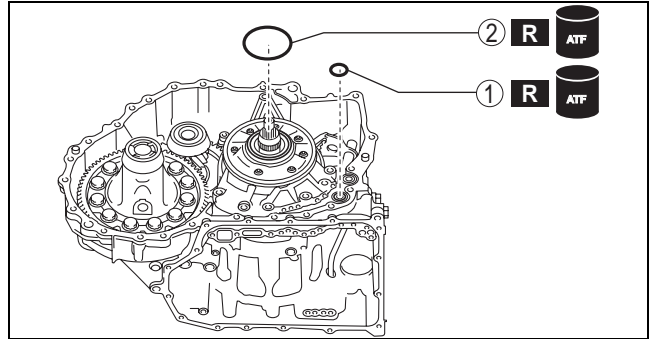

azzjiw00000652

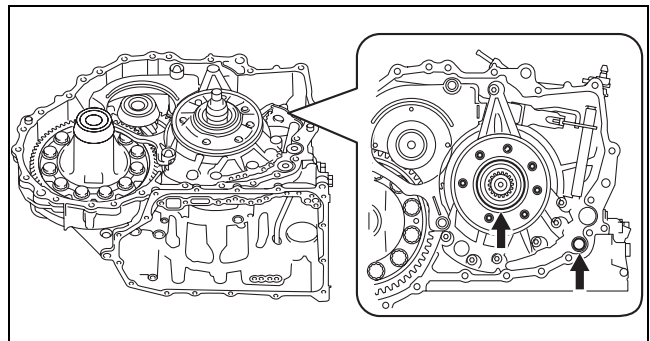

azzjiw00000653

(2) Remove any remaining old sealant on the contact surfaces of the transaxle case and converter housing, and degrease the contact surfaces.

Caution

- When degreasing and if degreaser is used, use a rag saturated with degreaser and be careful not to allow degreaser to penetrate the interior of the transaxle. In addition, after degreasing, visually verify that there is no foreign matter (such as old sealant, cloth fibers) which has penetrated the interior of the transaxle.

(3) Apply sealant (silicone sealant TB1217E) to the transaxle case.

Caution

- If sealant is applied excessively or applied to a part other than the indicated part, the O-ring could deform and the sealant could penetrate the oil passage. Apply an appropriate amount of sealant to the indicated part.

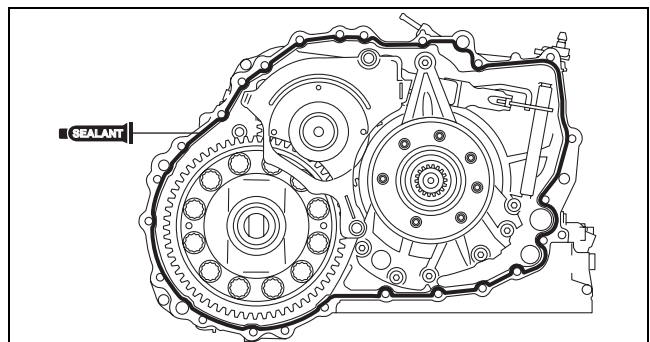

azzjiw00000654

Note

- Sealant application amount (bead thickness): ϕ 1.8—2.5 mm {0.071—0.098 in}

AUTOMATIC TRANSAXLE

- (4) Assemble the converter housing before the applied sealant starts to harden.

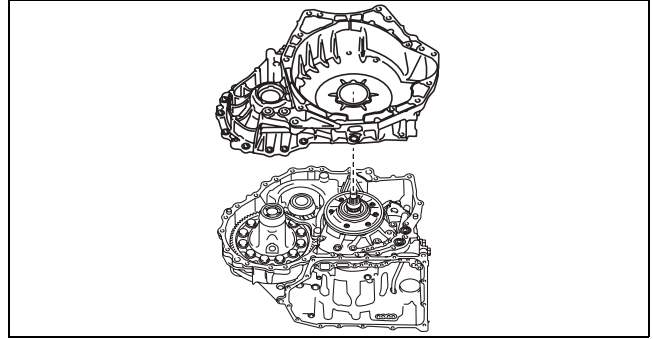

azzjw00000655

- (5) Assemble and temporarily tighten the bolts to the positions shown in the figure.

Note

- Bolt size: M8×1.25 bolt, length to approx. 28 mm {1.1 in}

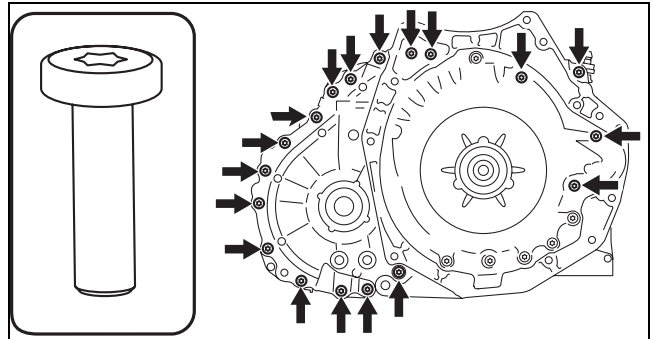

azzjw00000656

- (6) Assemble and temporarily tighten the new bolts to the positions shown in the figure.

Caution

- The bolts for the assembly are applied with sealant. If the bolts are reused it could cause ATF leakage, therefore use new bolts.

Note

- Bolt size: M8×1.25 bolt, length to approx. 28 mm {1.1 in} (with sealant applied)

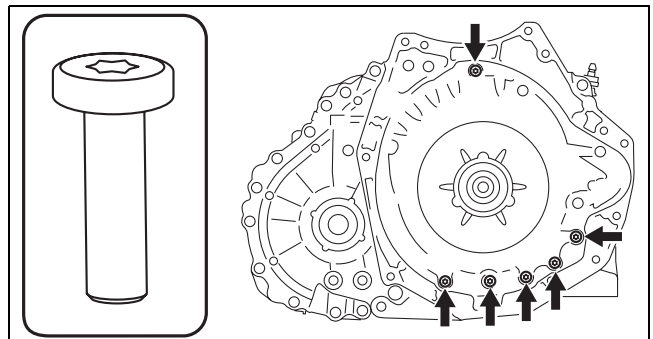

azzjw00000657

- (7) Tighten the bolts shown in the figure.

Tightening torque

19—25 N·m {2.0—2.5 kgf·m, 15—18 ft·lbf}

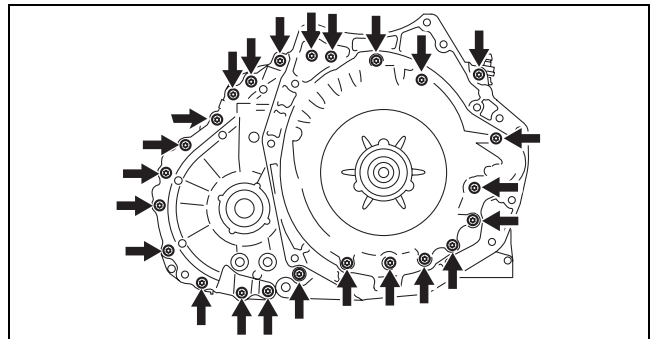

azzjw00000658

AUTOMATIC TRANSAXLE

44. Assemble the front sun gear.

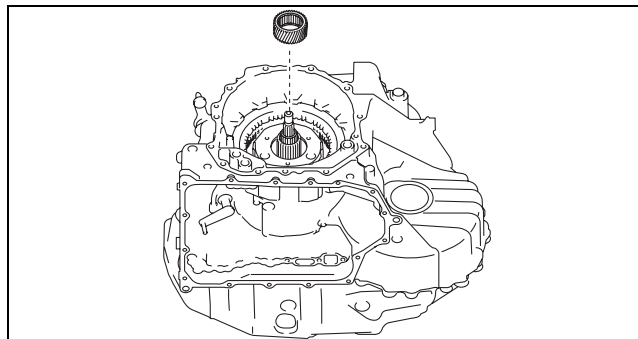

azzjw00000659

05-17

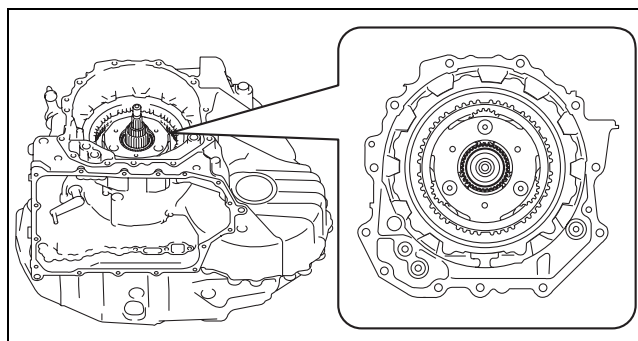

azzjw00000660

45. Assemble the rear sun gear.

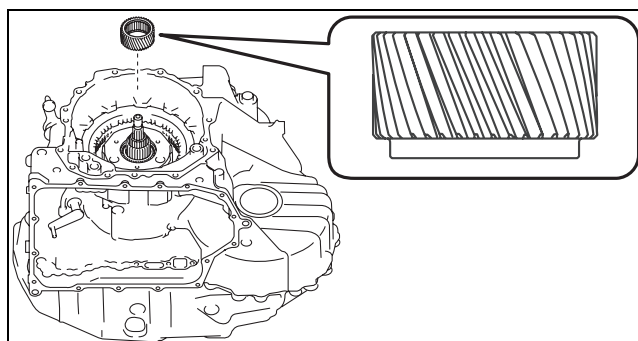

azzjw00000661

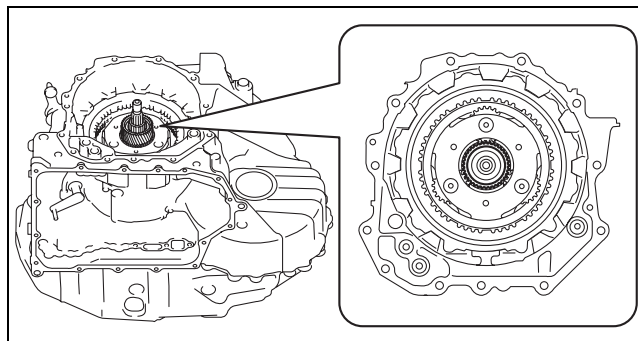

azzjw00000662

AUTOMATIC TRANSAXLE

46. Assemble the rear planetary gear using the following procedure:

(1) Assemble the rear planetary gear.

Note

- If the rear planetary gear assembly is difficult, assembly is easier if the work is performed using the following procedure:

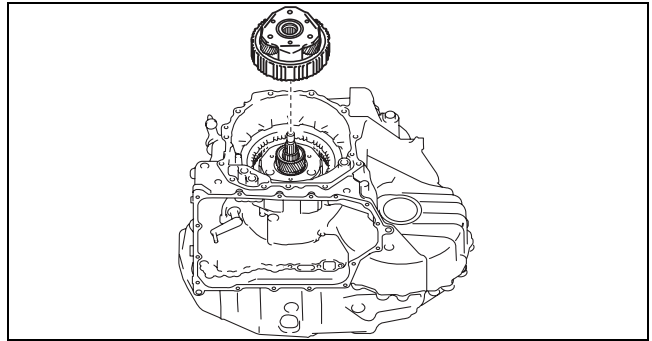

azzjiw00000663

1. Rotate and adjust the rotation handle of the engine stand so that the end cover side is situated sideways.

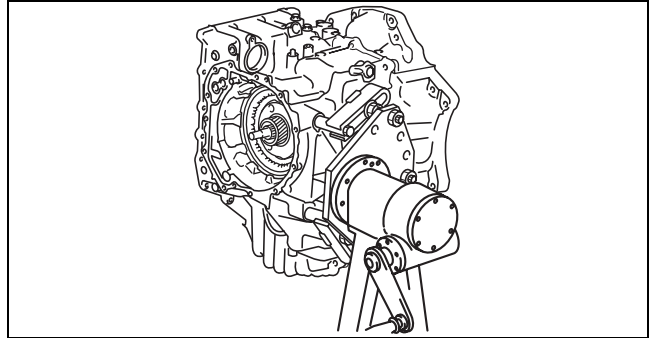

azzjiw00000664

2. While rotating the rear planetary gear, engage the splines of each drive plate of the low and reverse brake one by one, and assemble.

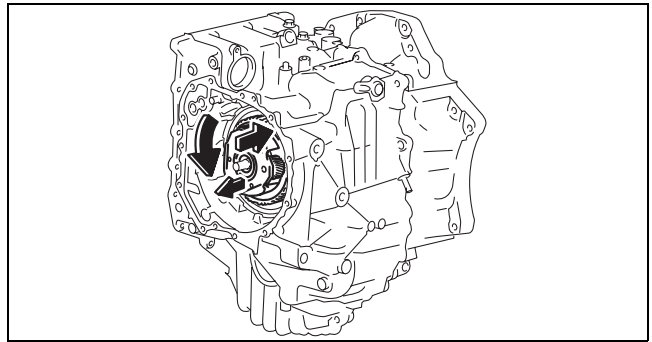

azzjiw00000665

(2) To verify that the rear planetary gear is securely assembled, measure the distance shown in the figure.

A : Transaxle case end (alignment surface with end cover)

B : Rear planetary gear end

Note

- Recommended measuring instrument:
Depth gauge, straight edge ruler

Specification

32.8—35.1 mm {1.30—1.38 in}

- If not within the specification, remove the rear planetary gear and reassemble.

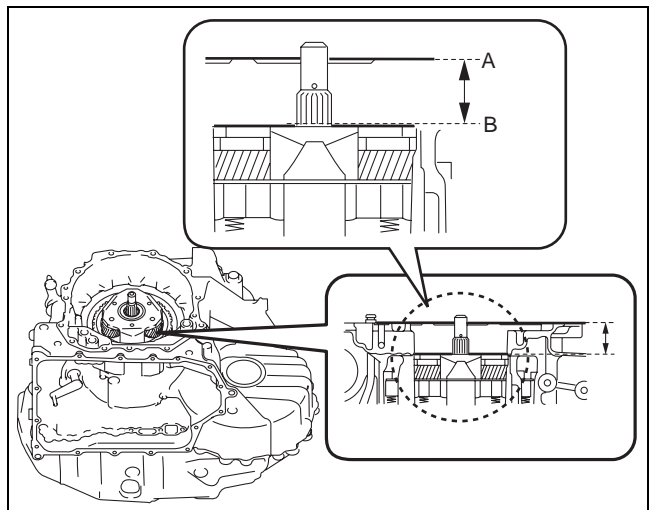

azzjiw00001606

Note

- Measurement method
- 1) Set two straight edge rulers along the alignment surface of the transaxle case with the end cover as shown in the figure.

A : Straight edge ruler

- 2) Measure the positions (2 locations) shown in the figure using a depth gauge and calculate the average value.
- 3) Subtract the thickness of the straight edge ruler from the average value.

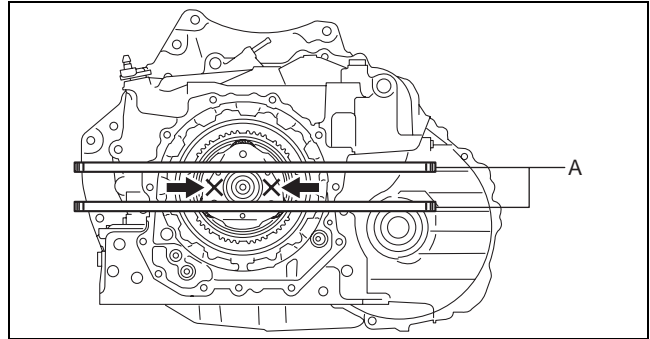

azzjw0000667

47. Assemble the thrust needle bearing.

Note

- Thrust needle bearing size: Outer diameter approx. 44 mm {1.7 in}

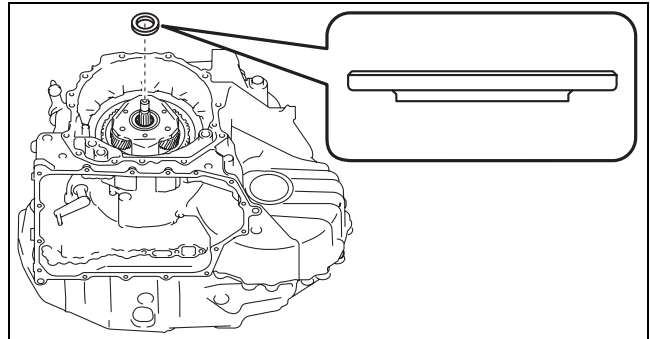

azzjw0000668

48. Assemble the reduction sun gear.

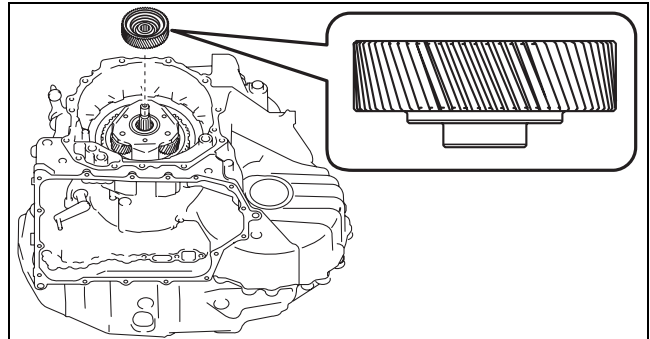

azzjw0000669

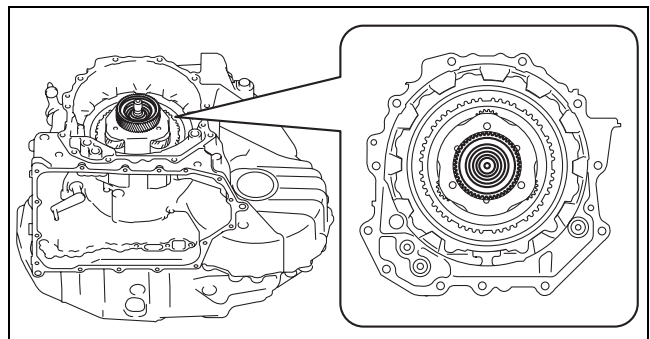

azzjw0000670

AUTOMATIC TRANSAXLE

49. Assemble the thrust needle bearing.

Note

- Thrust needle bearing size: Outer diameter approx. 61.5 mm {2.42 in}

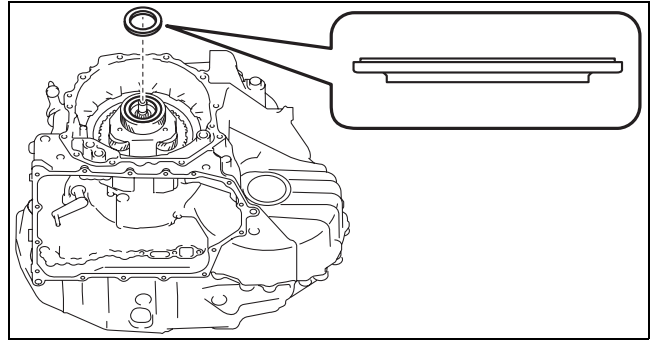

azzjw0000671

50. Assemble the shim using the following procedure:

Note

- Shim size: Outer diameter approx. 59.5 mm {2.34 in}

(1) Measure the total end play and select the appropriate shim. (See 05-17-385 TOTAL END PLAY MEASUREMENT/ADJUSTMENT.)

Caution

- The total end play is the play (gap) in the axial direction of each planetary gear. If the total end play adjustment is not performed, it may cause damage to the thrust needle bearing between each planetary gear or other parts.

(2) Assemble the selected shim in Step (1).

A : Selection

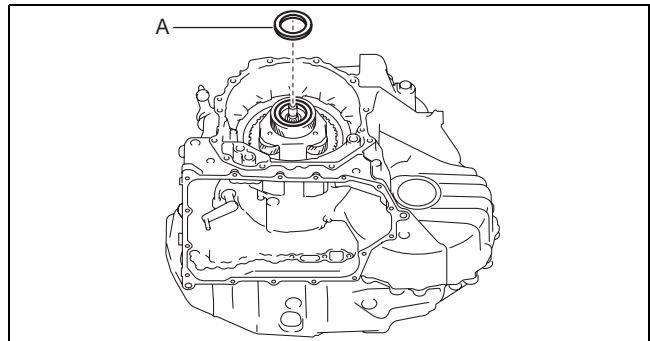

azzjw0000672

51. Assemble the end cover component using the following procedure:

1	O-ring (outer diameter approx. 15.6 mm {0.614 in}, thickness approx. 2.4 mm {0.094 in})
2	End cover component
3	12 bolts * (M8×1.25 bolt, length to approx. 21 mm {0.83 in})

* : Of the 12 bolts, 2 are applied with sealant

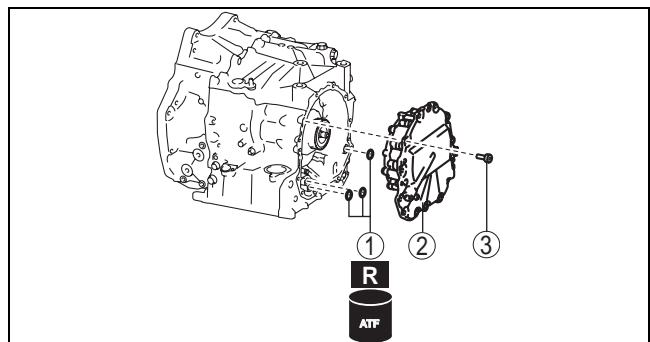

azzjw0000673

AUTOMATIC TRANSAXLE

(1) Assemble new O-rings using the following procedure:

Caution

- If an O-ring is reused it could cause ATF leakage, therefore use a new O-ring.

Note

- O-ring size: Outer diameter approx. 15.6 mm {0.614 in}, thickness approx. 2.4 mm {0.094 in}

- 1) Apply ATF (ATF FZ) to the new O-rings.
- 2) Assemble the new O-rings.

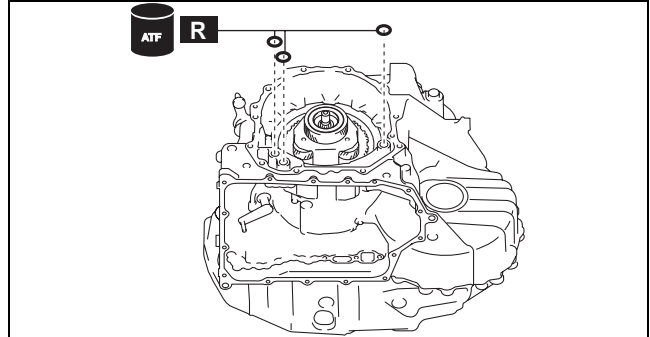

azzjjw00000674

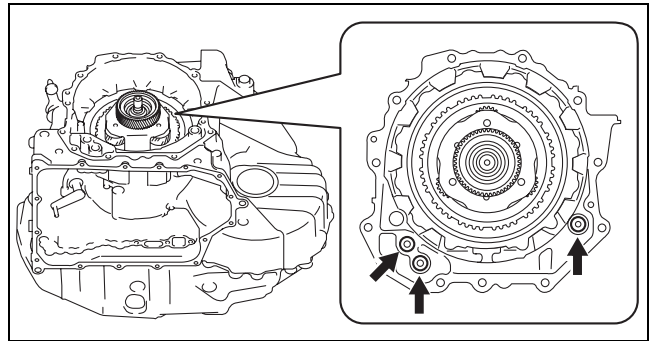

azzjjw00000675

(2) Remove any remaining old sealant on the contact surfaces of the transaxle case and end cover, and degrease the contact surfaces.

Caution

- When degreasing and if degreaser is used, use a rag saturated with degreaser and be careful not to allow degreaser to penetrate the interior of the transaxle. In addition, after degreasing, visually verify that there is no foreign matter (such as old sealant, cloth fibers) which has penetrated the interior of the transaxle.

(3) Apply sealant (silicone sealant TB1217E) to the transaxle case.

Caution

- If sealant is applied excessively or applied to a part other than the indicated part, the O-ring could deform and the sealant could penetrate the oil passage. Apply an appropriate amount of sealant to the indicated part.

Note

- Sealant application amount (bead thickness): ϕ 0.5—1.8 mm {0.02—0.07 in}

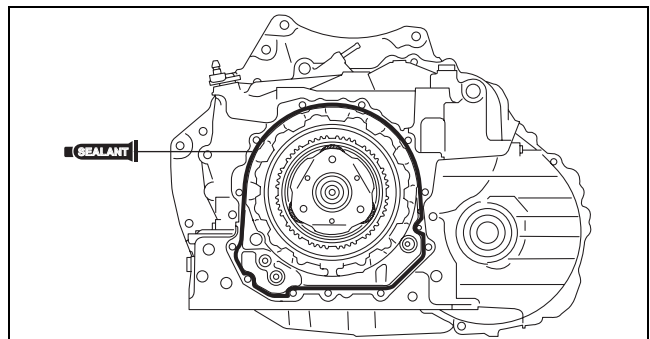

azzjjw00000676

05-17

AUTOMATIC TRANSAXLE

- (4) Assemble the end cover component before the applied sealant starts to harden.

Note

- Adjust the oil pipe and assemble the end cover component so that the oil pipe is assembled to the end cover oil passage.

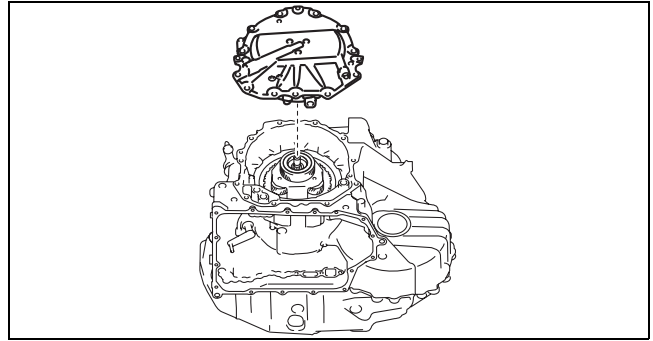

azzjw0000677

- A : End cover oil passage
B : Oil pipe

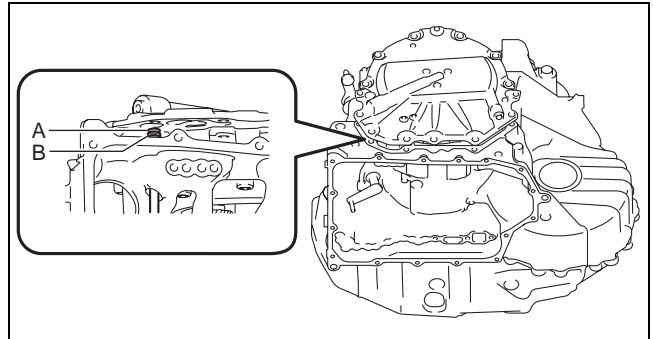

azzjw0000678

- (5) Assemble and temporarily tighten the bolts to the positions shown in the figure.

Note

- Bolt size: M8×1.25 bolt, length to approx. 21 mm {0.83 in}

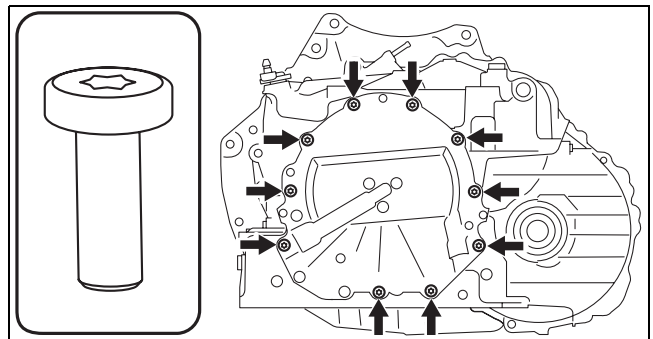

azzjw0000679

- (6) Assemble and temporarily tighten the new bolts to the positions shown in the figure.

Caution

- The bolts for the assembly are applied with sealant. If the bolts are reused it could cause ATF leakage, therefore use new bolts.

Note

- Bolt size: M8×1.25 bolt, length to approx. 21 mm {0.83 in} (with sealant applied)

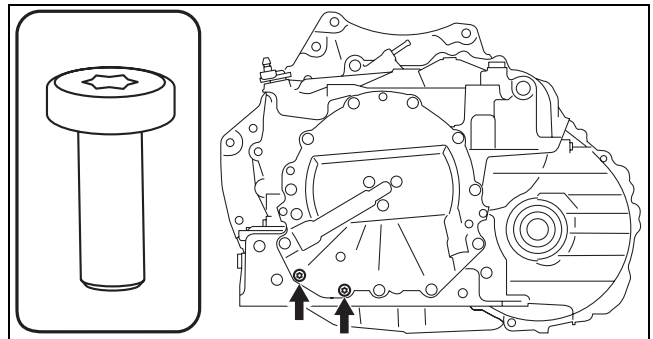

azzjw0000680

AUTOMATIC TRANSAXLE

(7) Tighten the bolts shown in the figure.

Tightening torque

19—25 N·m {2.0—2.5 kgf·m, 15—18 ft·lbf}

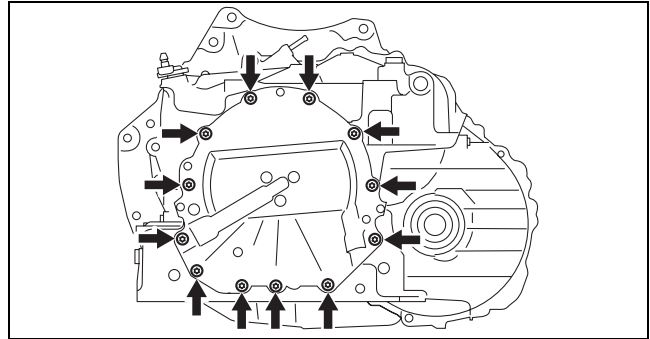

azzjjw00000681

05-17

52. Assemble the control valve body using the following procedure:

1	Gasket
2	Dowel pin
3	Control valve body
4	11 bolts (M6×1.0 bolt, length to approx. 30 mm {1.2 in})

Caution

- Do not drop or apply an impact to the control valve body. Replace the control valve body with a new one if it was dropped or received an impact.

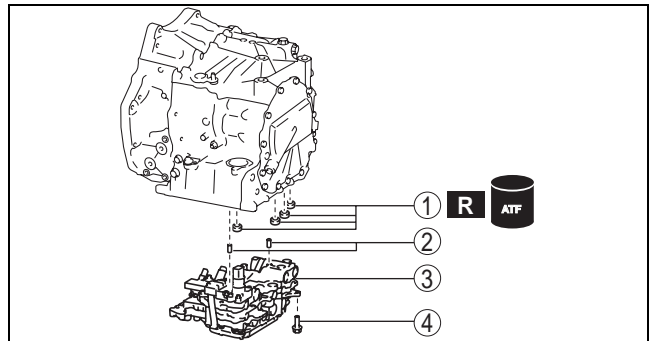

azzjjw00000682

(1) Assemble new gaskets using the following procedure:

Caution

- If a gasket is reused it could cause ATF leakage, therefore use a new gasket.

- 1) Apply ATF (ATF FZ) to the new gaskets.
- 2) Assemble the new gaskets.

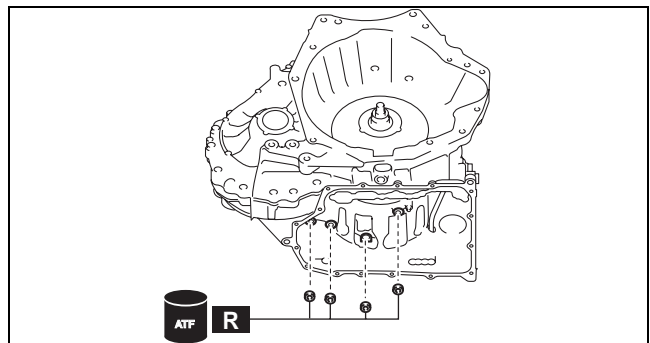

azzjjw00000683

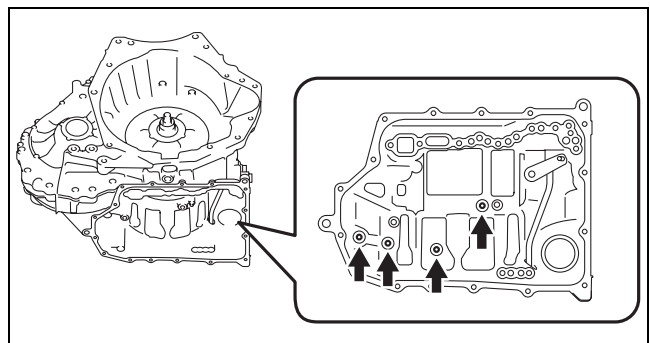

azzjjw00000684

AUTOMATIC TRANSAXLE

(2) Assemble the dowel pins.

Caution

- Do not assemble the dowel pin using a tool such as a hammer to prevent damaging the part. For the dowel pin assembly, only insert the dowel pin to the transaxle case assembly hole by hand.

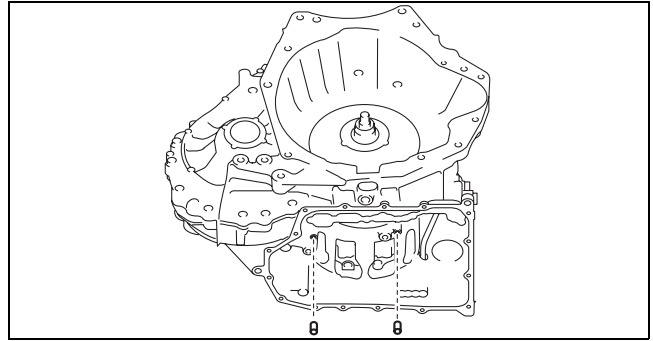

azzjw0000685

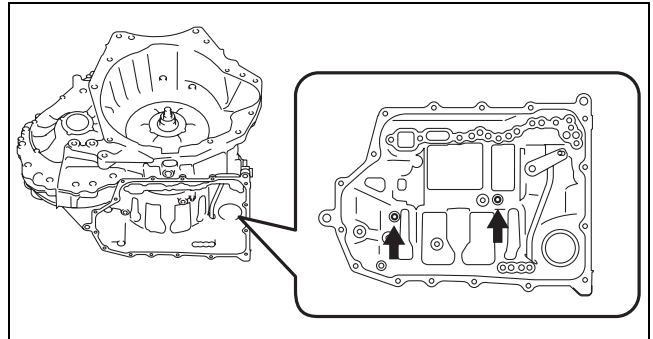

azzjw0000686

(3) Assemble the control valve body.

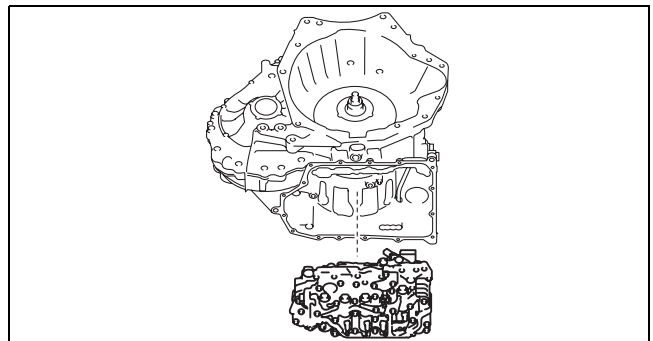

azzjw0000687

Caution

- Assemble the control valve body at a straight angle so that force is not applied to the control valve body connector in the lateral direction.
- Assemble the control valve body so that the TCM, turbine/input shaft speed sensor, and the output shaft speed sensor do not contact the transaxle case.

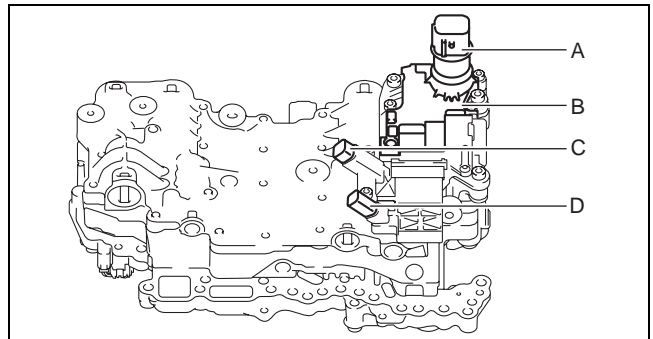

azzjw00001566

- A : Control valve body connector
B : TCM
C : Output shaft speed sensor
D : Turbine/input shaft speed sensor

AUTOMATIC TRANSAXLE

Caution

- Adjust the manual valve and assemble the control valve body so that the parking assist lever component end is engaged with the manual valve.

A : Parking assist lever component
B : Manual valve

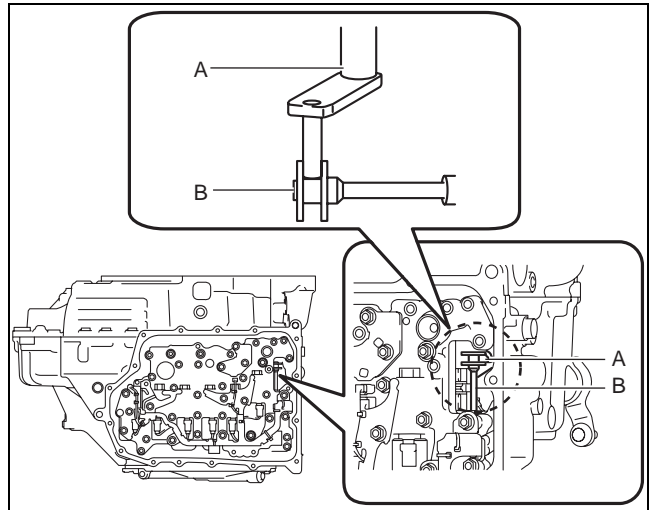

azzjw00000730

- (4) Assemble and tighten the bolts shown in the figure.

Note

- Bolt size: M6×1.0 bolt, length to approx. 30 mm {1.2 in}

Tightening torque

9—10 N·m {92—101 kgf·cm, 80—88 in·lbf}

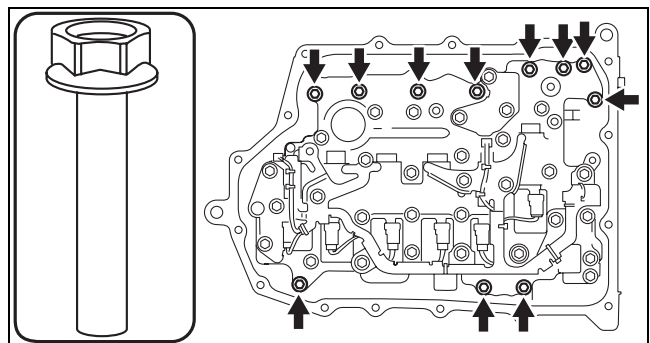

azzjw00000689

- (5) Move the manual valve in the direction shown in the figure and verify that the manual valve is engaged with the parking assist lever component end.

A : Manual valve

Note

- If the manual valve is only moved for excessive play on both surfaces of the parking assist lever component and the manual valve, the manual valve is correctly connected to the parking assist lever component.

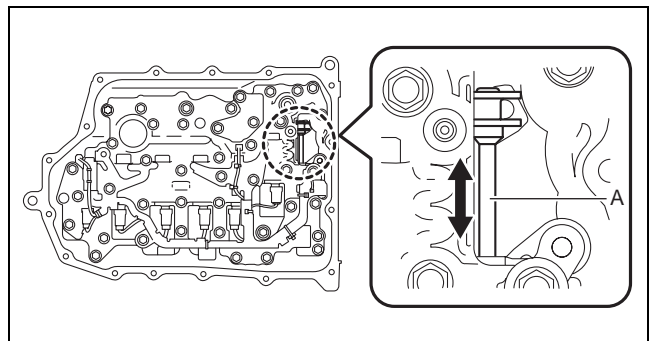

azzjw00001212

- If there is a malfunction, remove the control valve body and reassemble.

05-17

AUTOMATIC TRANSAXLE

53. Assemble a new oil strainer using the following procedure:

1	Oil strainer
2	2 bolts (M6×1.0 bolt, length to approx. 16 mm {0.63 in})

Caution

- If an oil strainer is reused while containing excessive foreign matter, it could cause an operation malfunction, therefore use a new oil strainer.

(1) Apply ATF (ATF FZ) to the new oil strainer O-rings.

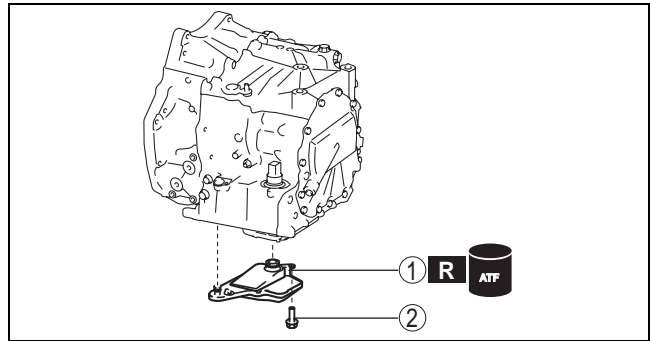

azzjw00001607

(2) Assemble the new oil strainer.

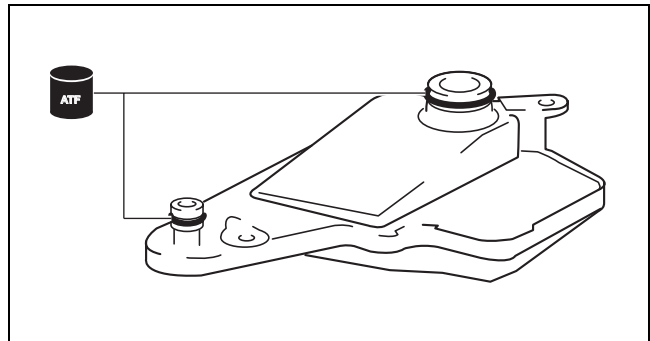

azzjw00001608

(3) Assemble and tighten the bolts shown in the figure.

Note

- Bolt size: M6×1.0 bolt, length to approx. 16 mm {0.63 in}

Tightening torque

9—10 N·m {92—101 kgf·cm, 80—88 in·lbf}

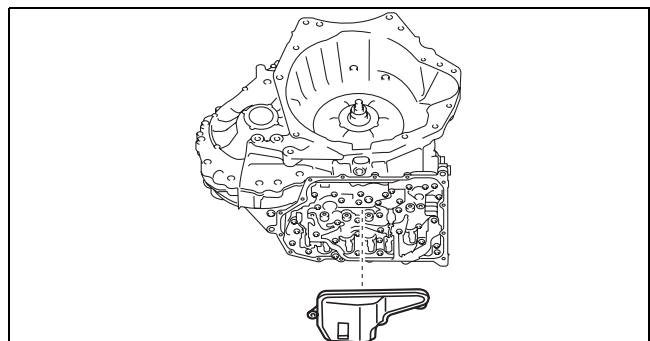

azzjw00000692

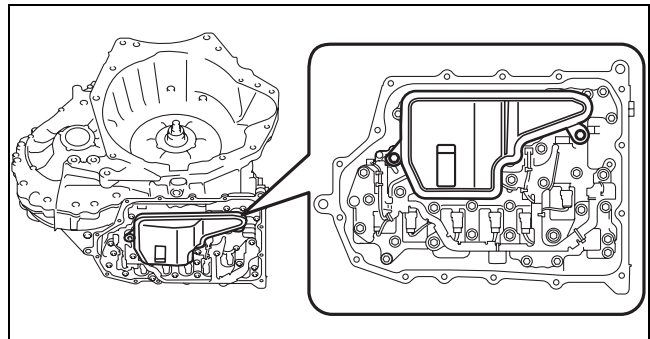

azzjw00000693

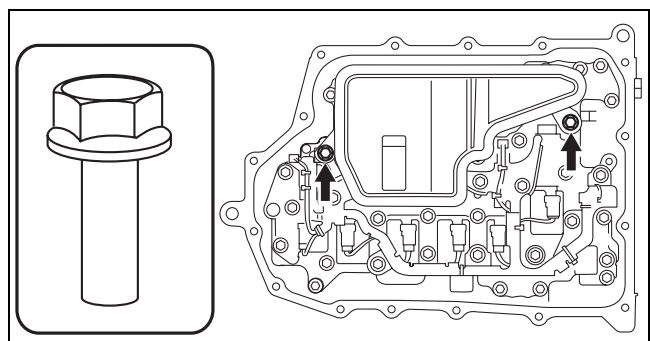

azzjw00000694

AUTOMATIC TRANSAXLE

54. Assemble the oil pan and magnet using the following procedure:

1	Magnet
2	Oil pan
3	16 bolts (M6×1.0 bolt, length to approx. 15 mm {0.59 in}*)

* : Length without spring washer is indicated due to bolt with spring washer. Length with spring washer is approx. 13 mm {0.51 in}.

(1) Assemble the magnet.

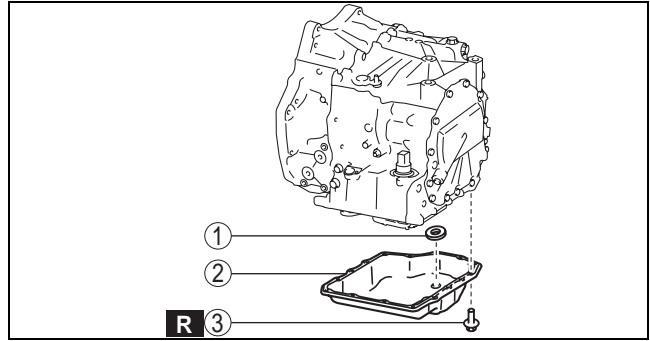

05-17

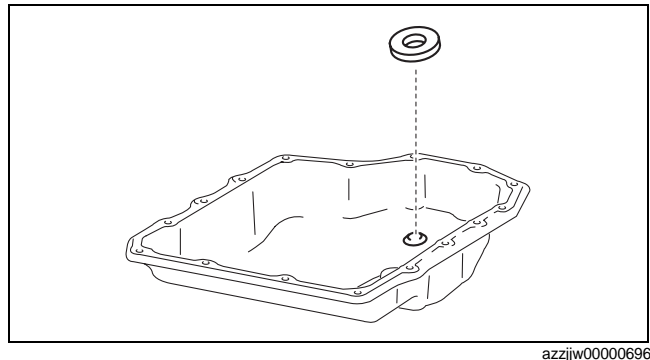

(2) Remove any remaining old sealant on the contact surfaces of the transaxle case and oil pan, and degrease the contact surfaces.

Caution

- **When degreasing and if degreaser is used, use a rag saturated with degreaser and be careful not to allow degreaser to penetrate the interior of the transaxle. In addition, after degreasing, visually verify that there is no foreign matter (such as old sealant, cloth fibers) which has penetrated the interior of the transaxle.**

(3) Apply sealant (silicone sealant TB1217E) to the oil pan.

Caution

- **If sealant is applied excessively or applied to a part other than the indicated part, the sealant could penetrate the transaxle inside. Apply an appropriate amount of sealant to the indicated part.**

Note

- Sealant application amount (bead thickness): ϕ 1.9—6.7 mm {0.08—0.26 in}

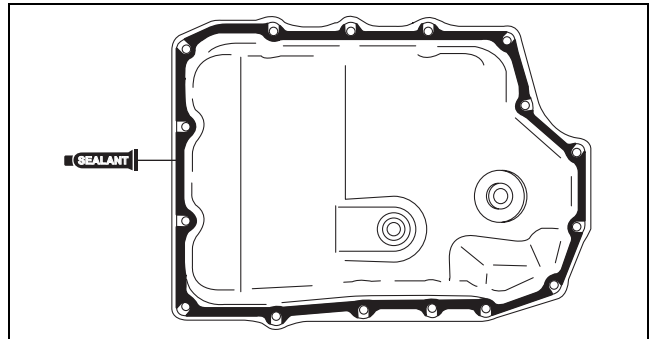

(4) Assemble the oil pan before the applied sealant starts to harden.

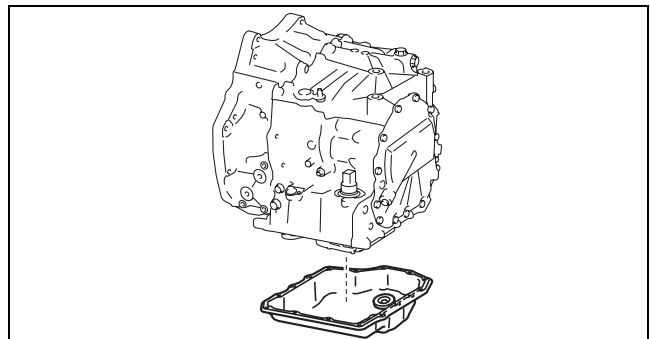

AUTOMATIC TRANSAXLE

- (5) Assemble and tighten the new bolts to the positions shown in the figure.

Caution

- The bolts for assembling are used for bolts with spring washer. If the bolts with spring washer are reused it could loosen the bolts due to spring weakness, therefore use new bolts.

Note

- Bolt size: M6×1.0 bolt, length to approx. 15 mm {0.59 in}^{*}

* : Length without spring washer is indicated due to bolt with spring washer. Length with spring washer is approx. 13 mm {0.51 in}.

Tightening torque

8—10 N·m {82—101 kgf·cm, 71—88 in·lbf}

55. Assemble a new oil seal using the following procedure:

Caution

- If an oil seal is reused it could cause ATF leakage, therefore use a new oil seal.

- (1) Apply ATF (ATF FZ) to the engagement area of the new oil seal and transaxle case.
- (2) Apply ATF (ATF FZ) to the engagement area of the new oil seal and connector.
- (3) Assemble the new oil seal to the position shown in the figure using the SST.

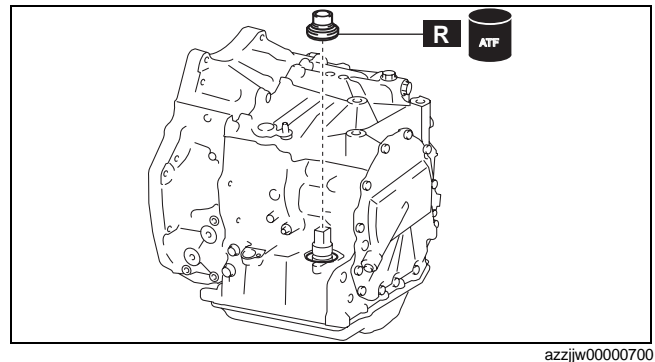
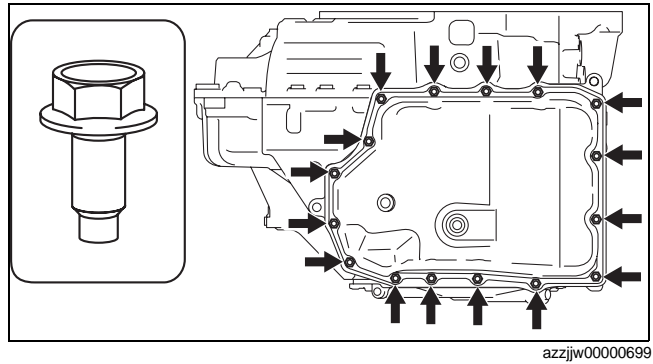

A : -0.5—1.5 mm {-0.01—0.05 in}

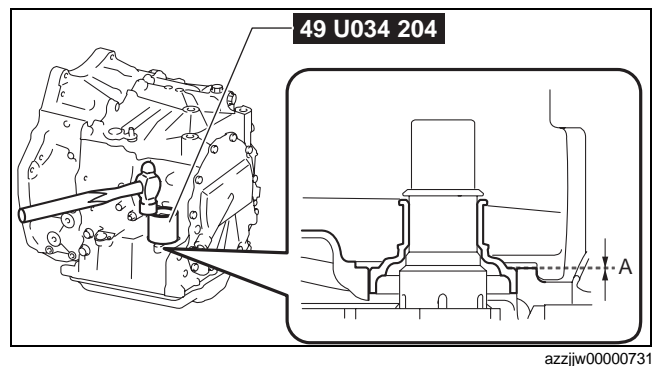

AUTOMATIC TRANSAXLE

56. Remove the SSTs from the transaxle using the following procedure:

Caution

- When removing the transaxle from the SST (engine stand) using chain hoists, be careful not to allow the transaxle to contact the SST (engine stand). If the transaxle contacts the SST, check the areas that made contact and replace damaged parts with new ones.

- (1) Assemble the SSTs using part number: 9YA02 1015, or M10×1.5 bolts, length to 35 mm {1.4 in}.

A : Part number: 9YA02 1015, or M10×1.5 bolt, length to 35 mm {1.4 in}

Tightening torque

38—52 N·m {3.9—5.3 kgf·m, 29—38 ft·lbf}

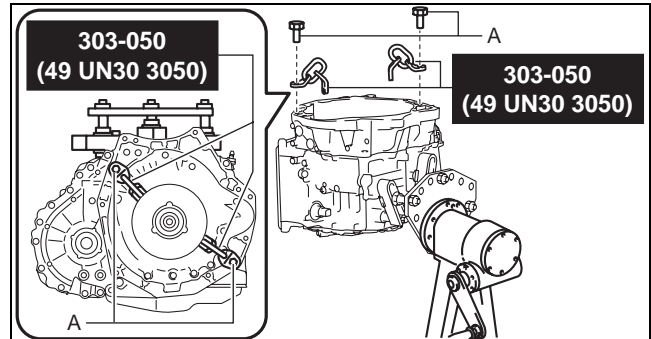

azzjw00000702

- (2) Using chain hoists, remove the SST (engine stand) from the transaxle.

A : Part number: 9YA02 A220, or M12×1.75 bolt, length to 40 mm {1.6 in}

Caution

- When removing the transaxle from the SST (engine stand) using chain hoists, be careful not to allow the transaxle to contact the SST (engine stand). If the transaxle contacts the SST, check the areas that made contact and replace damaged parts with new ones.

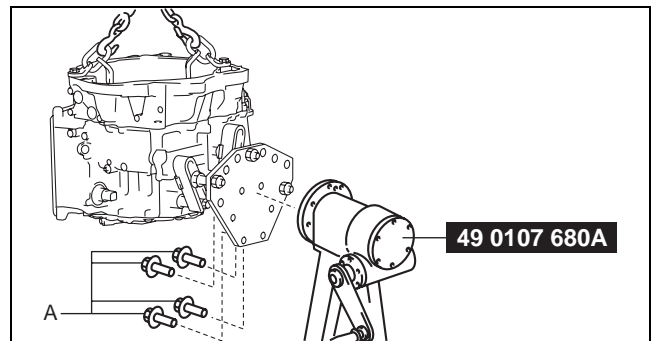

azzjw00000703

- (3) Remove the SSTs.

A : Part number: 9YA02 1015, or M10×1.5 bolt, length to 35 mm {1.4 in}

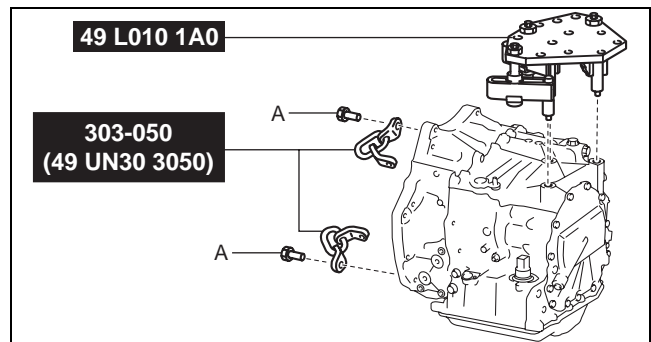

azzjw00000704

- (4) Disassemble the SST.

A : Part number: 9YA02 1440, or M14×1.5 bolt, length to 100 mm {3.94 in}

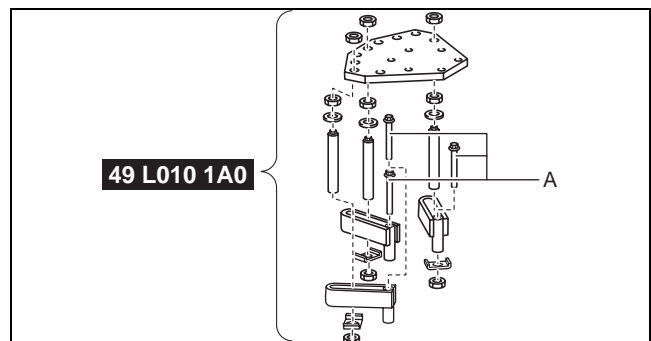

azzjw00000705

05-17

AUTOMATIC TRANSAXLE

57. Assemble a new hose clamp using the following procedure:

Caution

- If a hose clamp is reused it could cause ATF leakage, therefore use a new hose clamp.

- (1) Assemble the new hose clamp to the position shown in the figure.

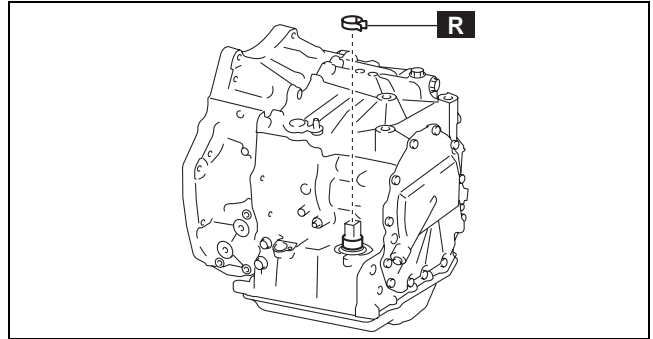

azzjiw00000706

Caution

- Assemble the hose clamp tab to within the range shown in the figure.

A : 210°

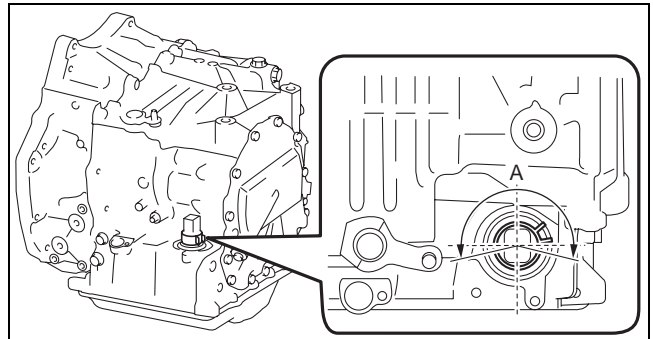

azzzcw00000084

- (2) Verify that the hose clamp is assembled to within the position shown in the figure.

A : Hose clamp assembly area
B : Hose clamp
C : Oil seal flange

Caution

- Verify that the hose clamp does not contact the oil seal flange.
- If not within the area, adjust so that the hose clamp assembly position is within the area.

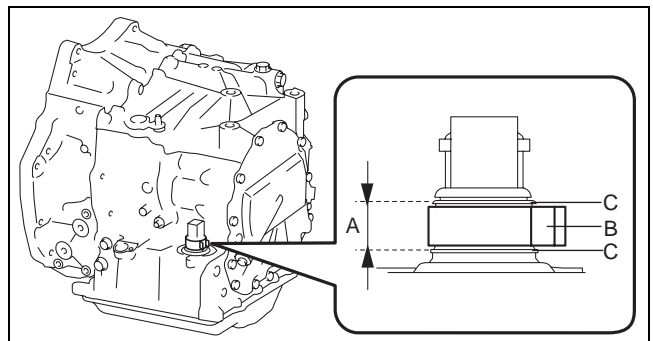

azzjiw00000732

AUTOMATIC TRANSAXLE

58. Assemble the dipstick using the following procedure:

1	O-ring (outer diameter approx. 16.6 mm {0.654 in}, thickness approx. 2.4 mm {0.094 in})
2	Dipstick
3	Bolt (M6×1.0 bolt, length to approx. 16 mm {0.63 in})

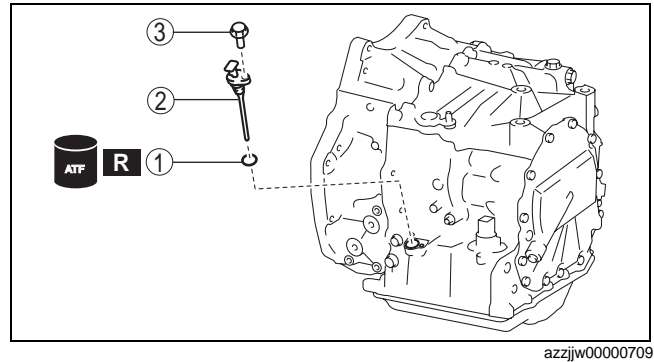

azzjw00000709

05-17

(1) Assemble a new O-ring using the following procedure:

Caution

- If an O-ring is reused it could cause ATF leakage, therefore use a new O-ring.

Note

- O-ring size: Outer diameter approx. 16.6 mm {0.654 in}, thickness approx. 2.4 mm {0.094 in}

- 1) Apply ATF (ATF FZ) to the new O-ring.
- 2) Assemble the new O-ring.

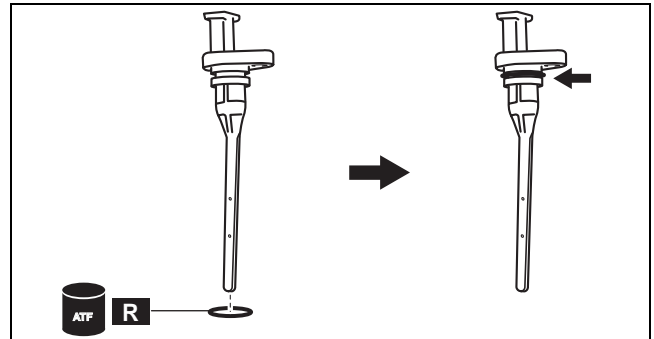

azzjw00000710

(2) Assemble the dipstick.

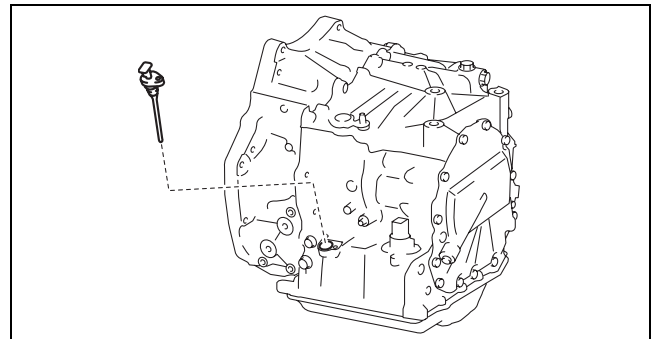

azzjw00000711

(3) Assemble and tighten the bolt shown in the figure.

Note

- Bolt size: M6×1.0 bolt, length to approx. 16 mm {0.63 in}

Tightening torque

8—11 N·m {82—112 kgf·cm, 71—97 in·lbf}

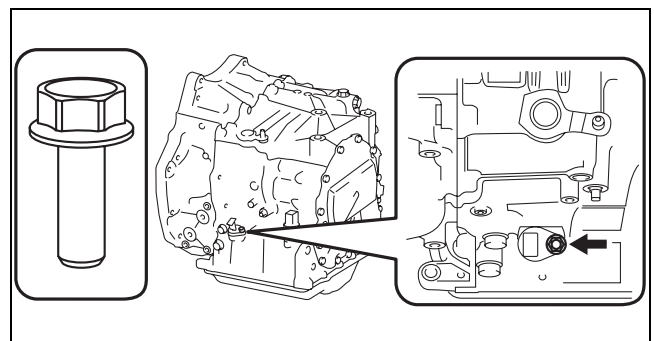

azzjw00000712

AUTOMATIC TRANSAXLE

59. Assemble the oil cooler using the following procedure:

1	O-ring (outer diameter approx. 24.4 mm {0.961 in}, thickness approx. 2.4 mm {0.094 in})
2	Oil cooler
3	3 bolts (M8×1.25 bolt, length to approx. 25 mm {0.98 in})

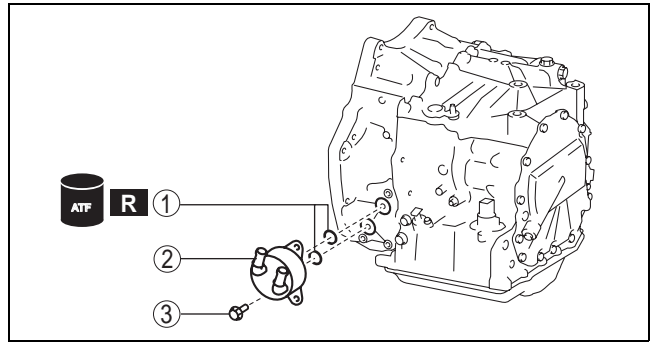

azzjiw00000713

(1) Assemble new O-rings using the following procedure:

Caution

- If an O-ring is reused it could cause ATF leakage, therefore use a new O-ring.

Note

- O-ring size: Outer diameter approx. 24.4 mm {0.961 in}, thickness approx. 2.4 mm {0.094 in}

- 1) Apply ATF (ATF FZ) to the new O-rings.
- 2) Assemble the new O-rings.

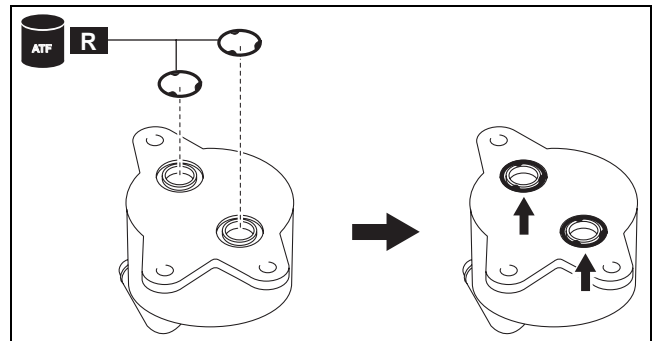

azzjiw00000714

(2) Assemble the oil cooler.

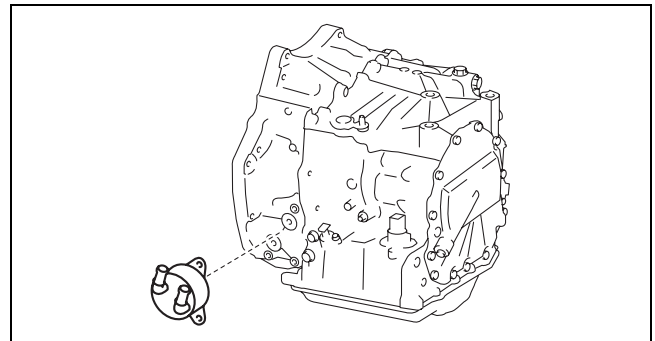

azzjiw00000715

(3) Assemble and tighten the bolts shown in the figure.

Note

- Bolt size: M8×1.25 bolt, length to approx. 25 mm {0.98 in}

Tightening torque

22—27 N·m {2.3—2.7 kgf·m, 17—19 ft·lbf}

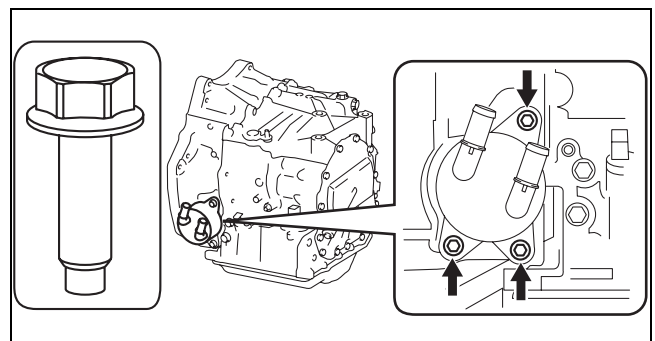

azzjiw00000716

AUTOMATIC TRANSAXLE

60. Assemble the torque converter using the following procedure:

- (1) Apply ATF (ATF FZ) to the stator shaft end of the oil pump shown in the figure.

Caution

- Accurately perform the procedure to protect the internal parts of the torque converter.

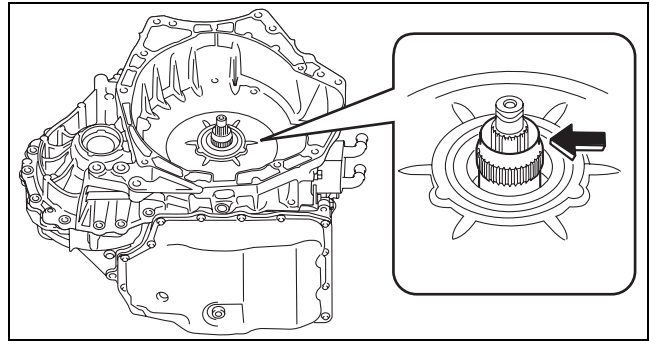

azzzcw0000085

- (2) Assemble the torque converter so that the two surfaces of the notch on the end of the torque converter engage the inner rotor of the oil pump.

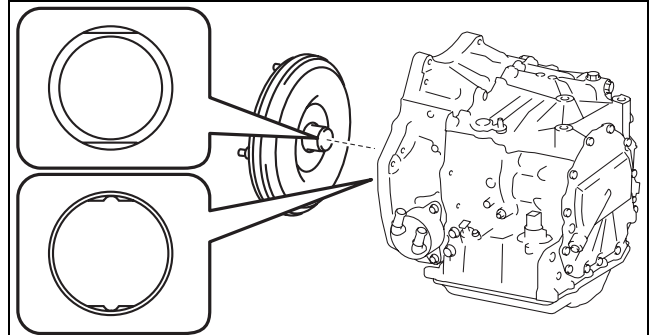

azzjw00000717

- (3) To verify that the torque converter is securely assembled, measure the distance shown in the figure.

- A : Converter housing end (alignment surface with engine)
B : Stud bolt seating face of torque converter

Note

- Recommended measuring instrument:
Depth gauge, straight edge ruler

Specification

14.6 mm {0.575 in} or more

- If not within the specification, remove the torque converter and reassemble.

Note

- Measurement method

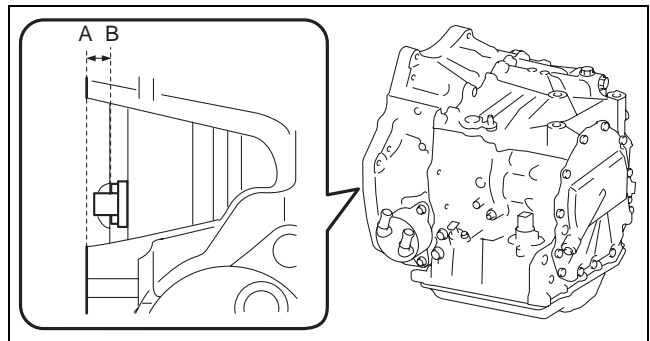

azzjw00001418

AUTOMATIC TRANSAXLE

- 1) Set two straight edge rulers along the alignment surface of the converter housing with the engine as shown in the figure.

A : Straight edge ruler

- 2) Measure the positions (2 locations) shown in the figure using a depth gauge and calculate the average value.
- 3) Subtract the thickness of the straight edge ruler from the average value.

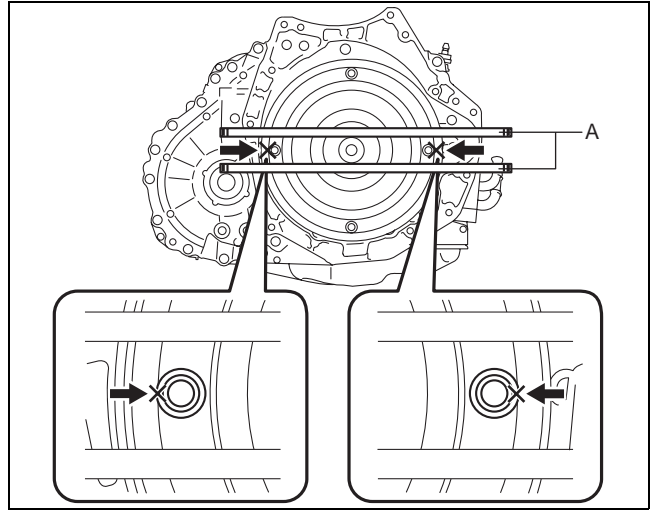

azzjiw00000719

61. Assemble and tighten the stud bolts.

Tightening torque

15—25 N·m {1.6—2.5 kgf·m, 12—18 ft·lbf}

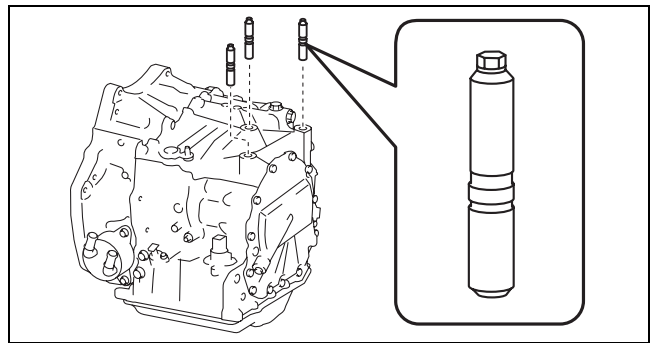

azzjiw00000720

AUTOMATIC TRANSAXLE

OIL PUMP ASSEMBLY

id051700663600

Structural View

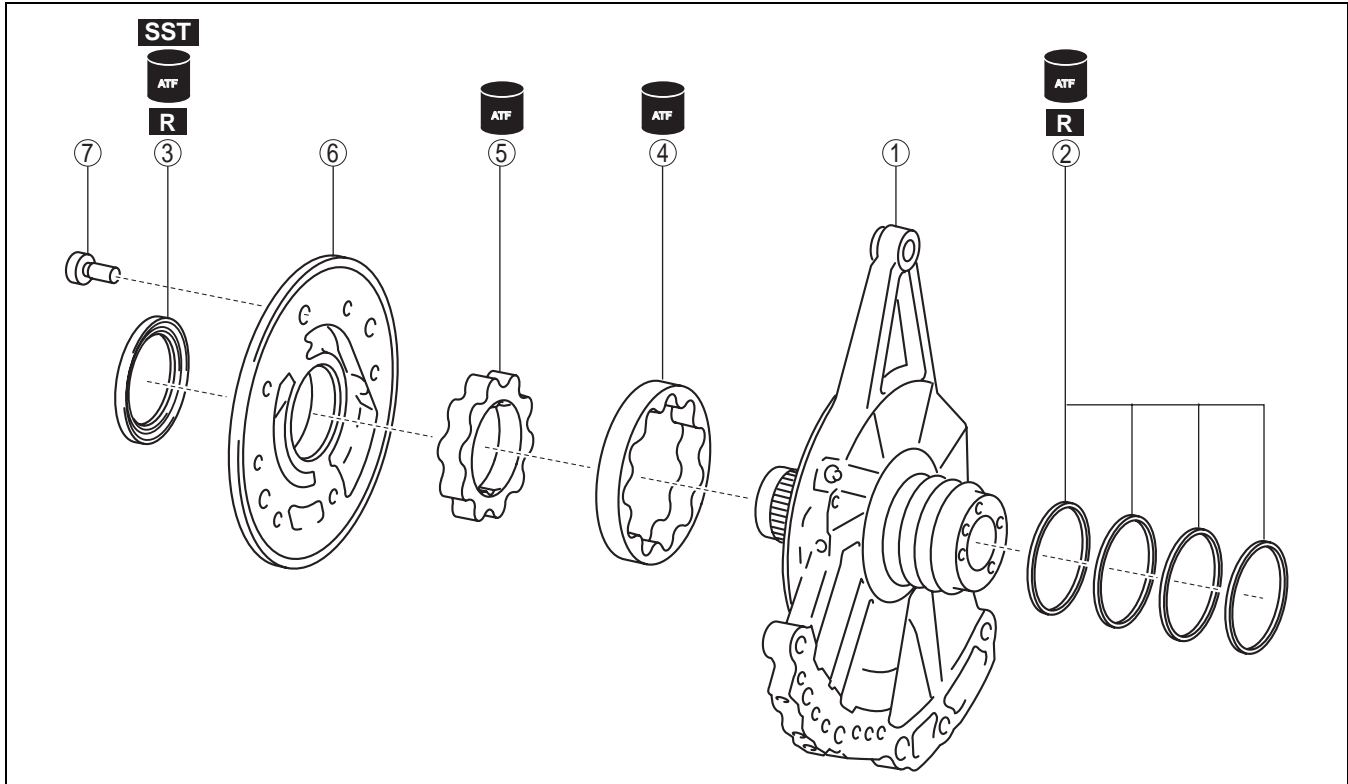

05-17

azzjjw00001530

1	Oil pump housing
2	Seal ring (outer diameter approx. 52.5 mm {2.07 in}, thickness approx. 1.5 mm {0.059 in})
3	Oil seal
4	Outer rotor

5	Inner rotor
6	Oil pump cover
7	7 bolts (M6×1.0 bolt, length to approx. 13 mm {0.51 in})

Assembly Procedure

1. Assemble new seal rings using the following procedure:

Caution

- If a seal ring is reused it could cause ATF leakage, therefore use a new seal ring.

Note

- Seal ring size: Outer diameter approx. 52.5 mm {2.07 in}, thickness approx. 1.5 mm {0.059 in}

- (1) Apply ATF (ATF FZ) to the new seal rings.

AUTOMATIC TRANSAXLE

(2) Assemble the new seal rings.

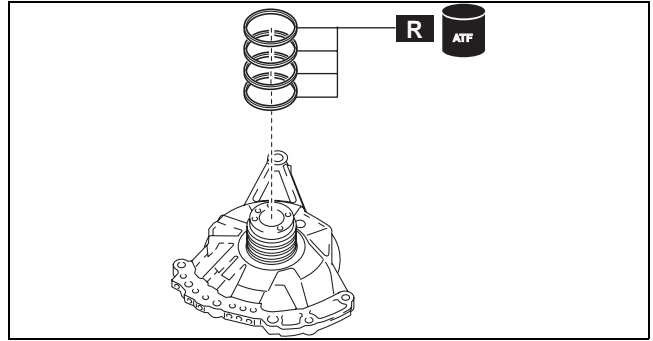

azzjiw00000883

A : Seal ring

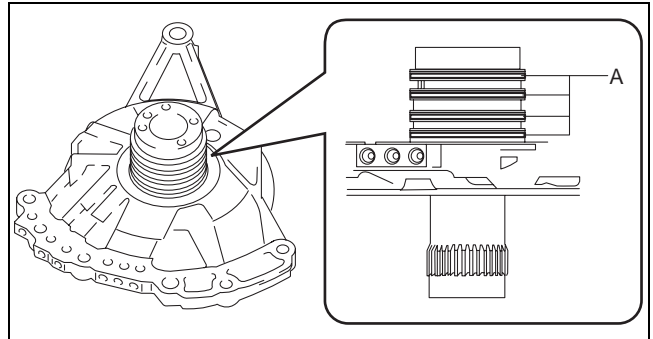

azzjiw00000884

2. Assemble the outer rotor using the following procedure:

- (1) Apply ATF (ATF FZ) to the outer rotor.
- (2) Assemble the outer rotor.

A : Mark

B : Assembly direction (oil pump housing side)

Note

- Assemble so that the outer rotor marking is facing the oil pump housing.

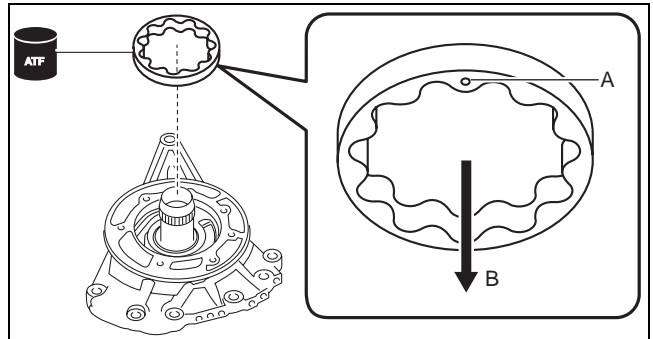

azzjiw00000885

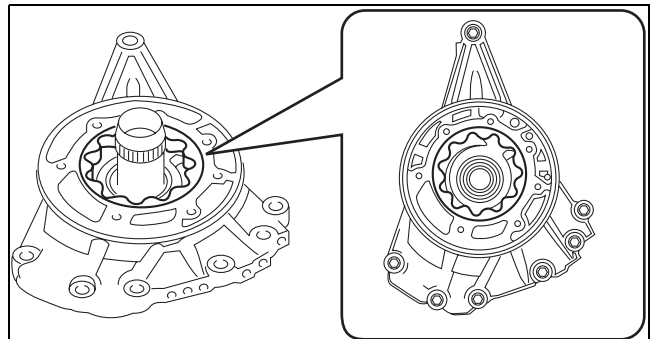

azzjiw00000886

AUTOMATIC TRANSAXLE

3. Assemble the inner rotor using the following procedure:

- (1) Apply ATF (ATF FZ) to the inner rotor.
- (2) Assemble the inner rotor.

A : Mark

B : Assembly direction (oil pump housing side)

Note

- Assemble so that the inner rotor marking is facing the oil pump housing.

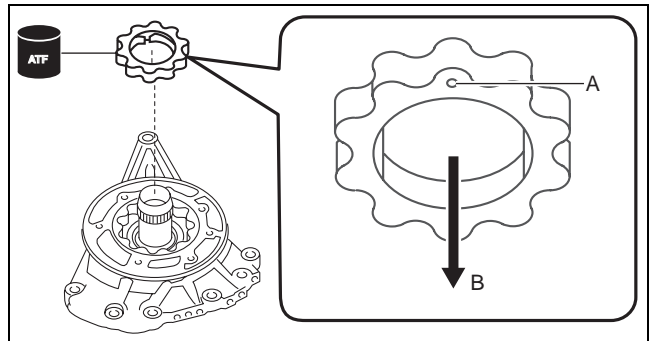

azzjw00001531

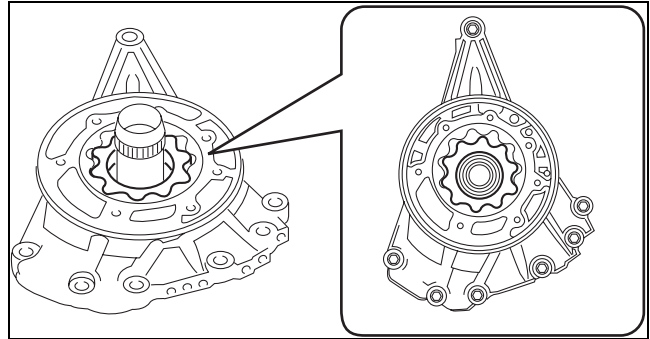

azzjw00000888

4. Assemble a new oil seal using the following procedure:

Caution

- If an oil seal is reused it could cause ATF leakage, therefore use a new oil seal.

- (1) Apply ATF (ATF FZ) to the engagement area of the new oil seal and oil pump cover.
- (2) Apply ATF (ATF FZ) to the lip of the new oil seal.
- (3) Assemble the new oil seal to the position shown in the figure using the SST.

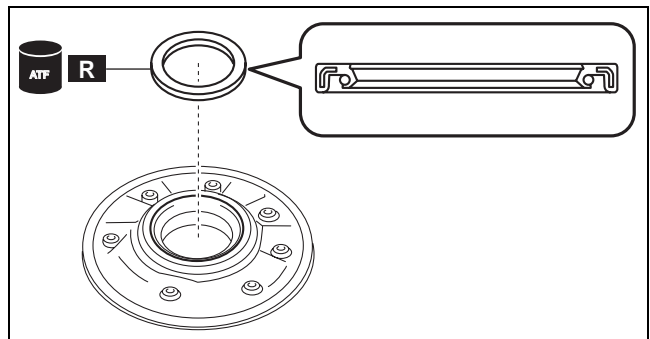

azzjw00000889

A : 0—0.5 mm {0—0.01 in}

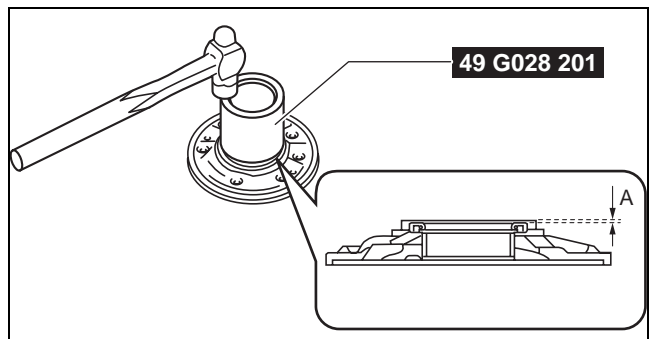

azzjw00000890

05-17

AUTOMATIC TRANSAXLE

5. Assemble the oil pump cover using the following procedure:

1	Oil pump cover
2	7 bolts (M6×1.0 bolt, length to approx. 13 mm {0.51 in})

(1) Assemble the oil pump cover.

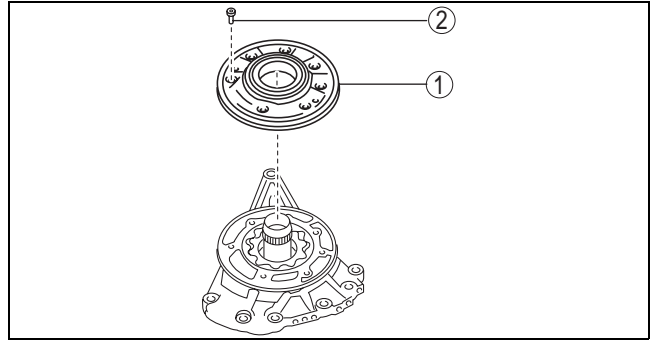

azzjw00000891

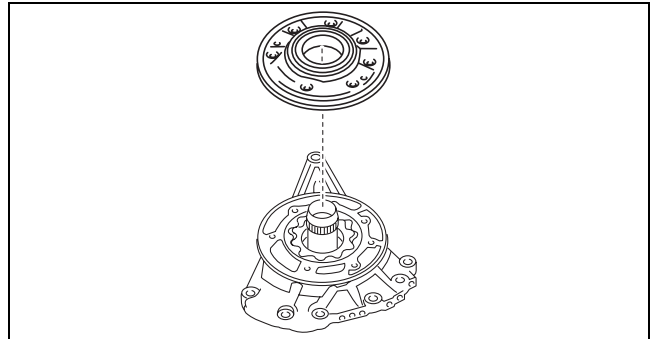

azzjw00000892

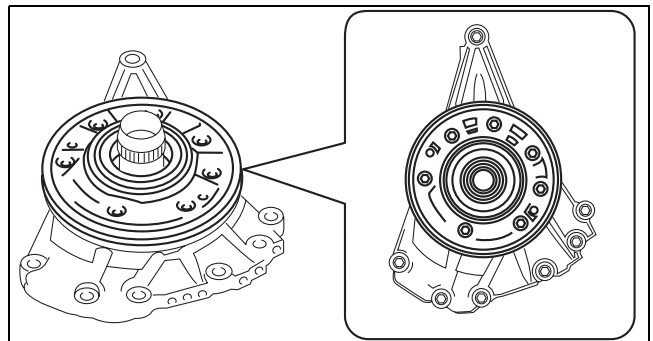

azzjw00000893

(2) Assemble and tighten the bolts shown in the figure.

Note

- Bolt size: M6×1.0 bolt, length to approx. 13 mm {0.51 in}

Tightening torque

9—10 N·m {92—101 kgf·cm, 80—88 in·lbf}

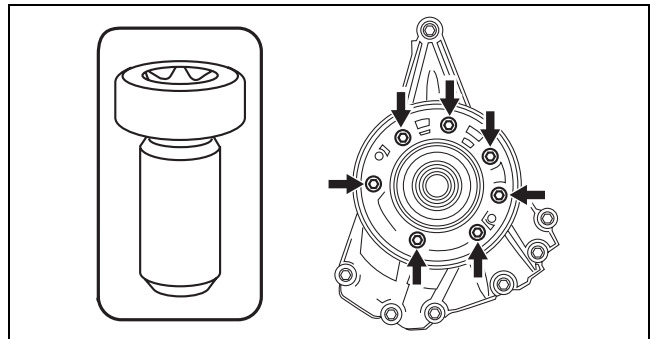

azzjw00000894

AUTOMATIC TRANSAXLE

CLUTCH COMPONENT ASSEMBLY

id051700663700

Structural View

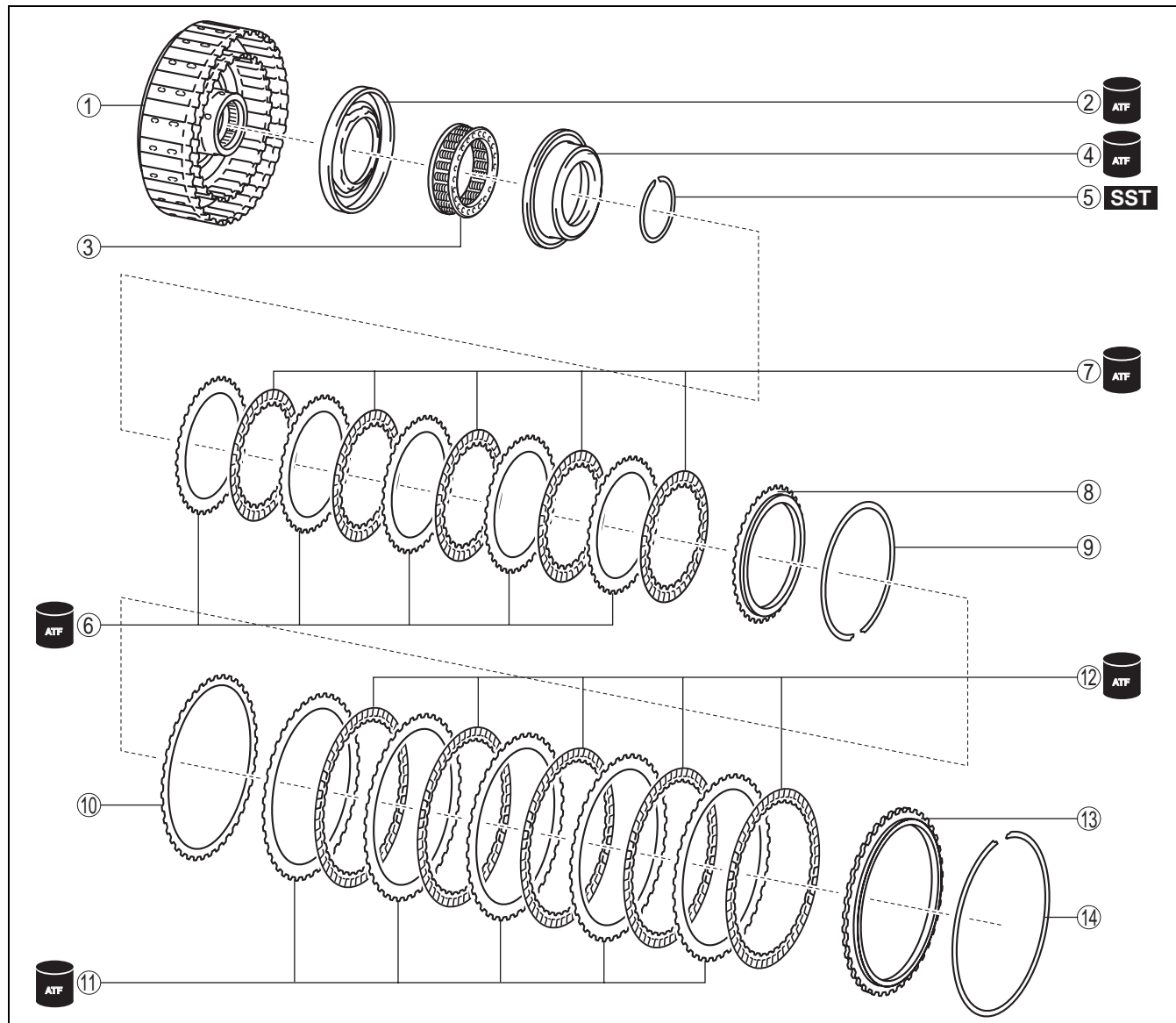

05-17

azzjjw00001532

1	High clutch drum component
2	High clutch piston
3	Springs and retainer component (outer diameter approx. 79.5 mm {3.13 in})
4	Seal plate
5	Snap ring (outer diameter approx. 56.5 mm {2.22 in})
6	Driven plate (inner diameter approx. 95.5 mm {3.76 in})
7	Drive plate (outer diameter approx. 116.8 mm {4.598 in})

8	Retaining plate (inner diameter approx. 95.5 mm {3.76 in})
9	Snap ring (outer diameter approx. 127.4 mm {5.016 in}) (selection)
10	Wave spring
11	Driven plate (inner diameter approx. 139.9 mm {5.508 in})
12	Drive plate (outer diameter approx. 159.1 mm {6.264 in})
13	Retaining plate (inner diameter approx. 139.9 mm {5.508 in})
14	Snap ring (outer diameter approx. 169.3 mm {6.665 in}) (selection)

AUTOMATIC TRANSAXLE

Assembly Procedure

1. Assemble the high clutch piston using the following procedure:
 - (1) Apply ATF (ATF FZ) to the high clutch piston lip.
 - (2) Assemble the high clutch piston.

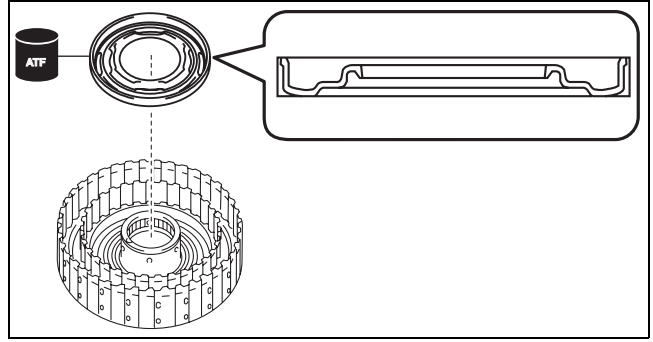

azzijw00000843

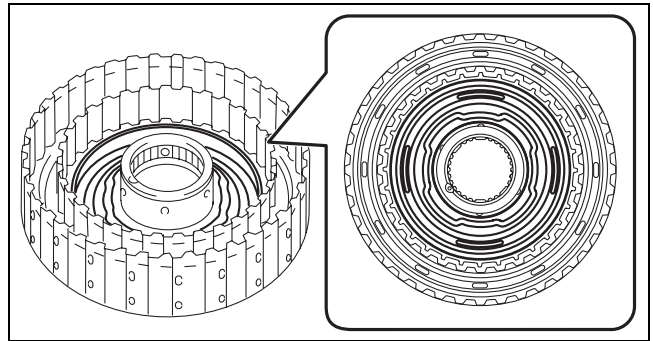

azzijw00000844

2. Assemble the springs and retainer component.

Note

- Springs and retainer component size: Outer diameter approx. 79.5 mm {3.13 in}

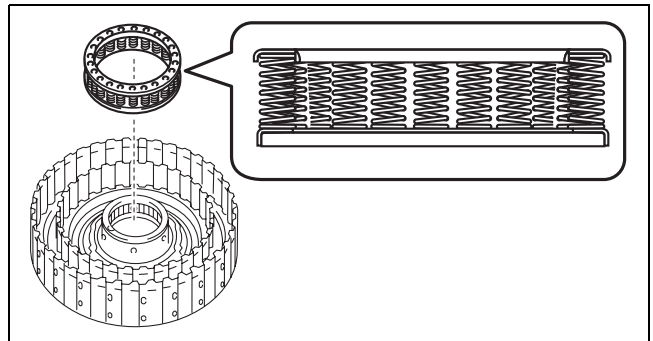

azzijw00001257

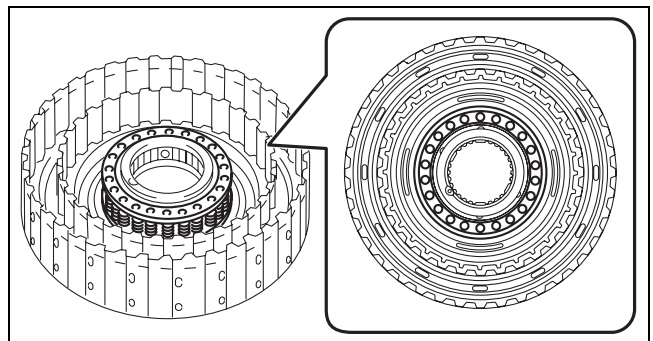

azzijw00000846

AUTOMATIC TRANSAXLE

3. Assemble the seal plate using the following procedure:

- (1) Apply ATF (ATF FZ) to the seal plate lip.
- (2) Assemble the seal plate.

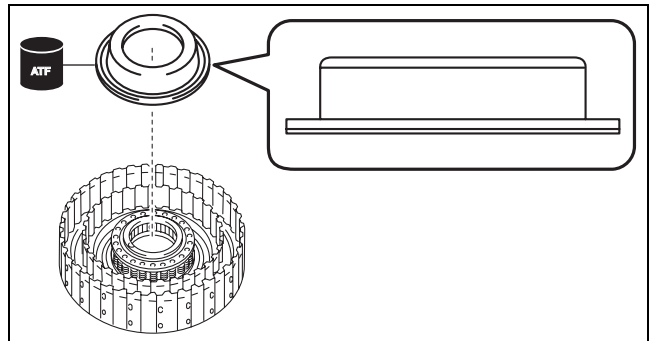

azzjw0000847

05-17

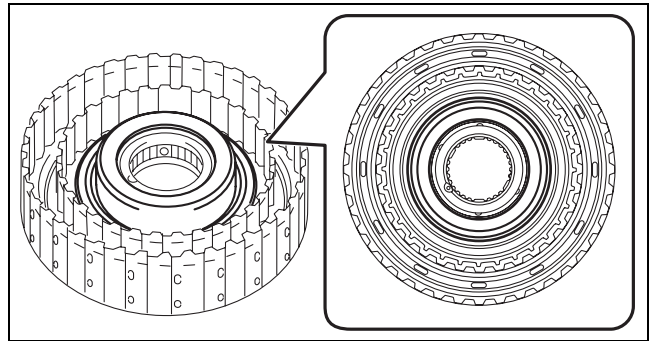

azzjw0000848

4. Assemble the snap ring using the following procedure:

Note

- Snap ring size: Outer diameter approx. 56.5 mm {2.22 in}

- (1) Set the snap ring to the top of the seal plate.

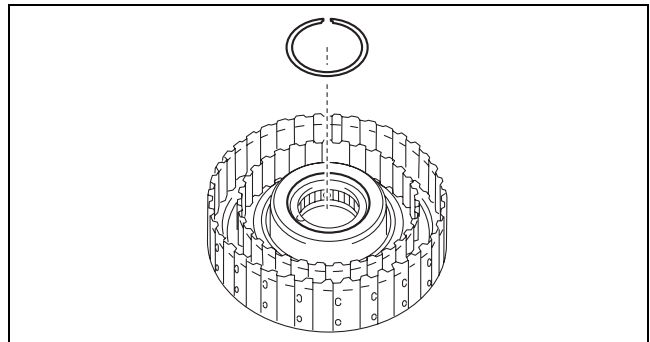

azzjw0000849

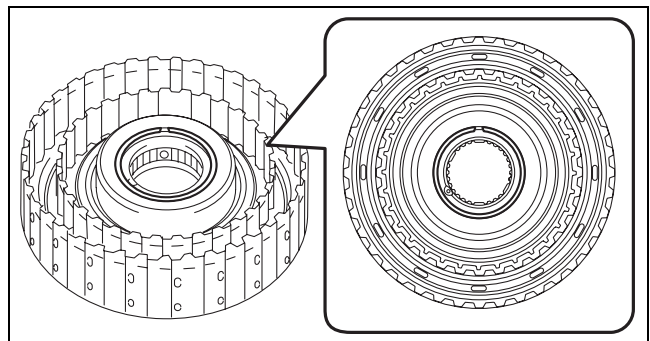

azzjw0000850

AUTOMATIC TRANSAXLE

(2) Install the SSTs.

- A : Nut included with SST (49 G019 025), or M8×1.25 nut
- B : Washer

Note

- When installing the SST (49 G019 025) to the SST (49 G019 026), use the nuts included with the SST (49 G019 025), or M8×1.25 nuts.

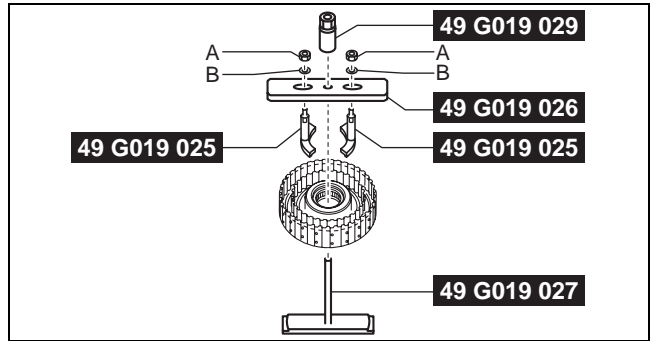

azzjiw00000851

- A : Nut included with SST (49 G019 025), or M8×1.25 nut
- B : Washer

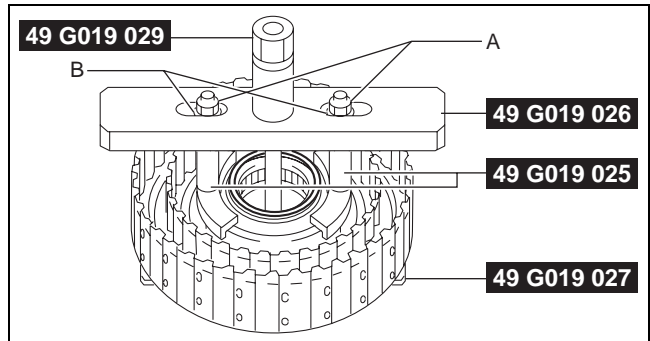

azzjiw00000852

(3) Tighten the SST (49 G019 029) until the snap ring groove of the high clutch drum component comes out.

- A : Snap ring groove

Caution

- If the SST (49 G019 029) is tightened with excessive force, surrounding parts could be damaged. Stop tightening the SST when the snap ring groove of the high clutch drum component comes out.

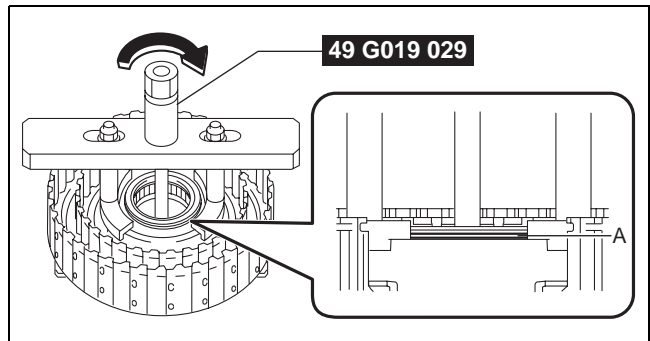

azzjiw00000853

AUTOMATIC TRANSAXLE

(4) Assemble the snap ring.

Caution

- After assembling the snap ring, verify that the snap ring is securely inserted into the bottom of the snap ring groove.

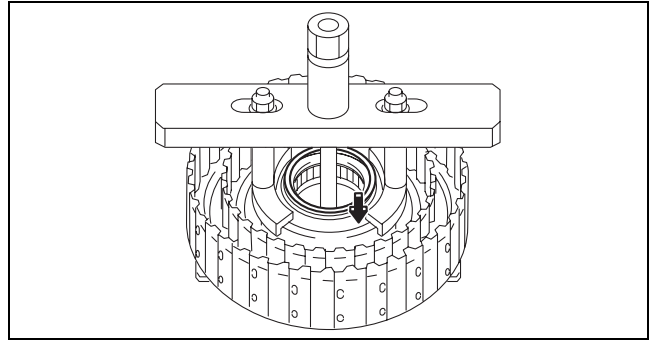

azzjw00000854

A : Snap ring

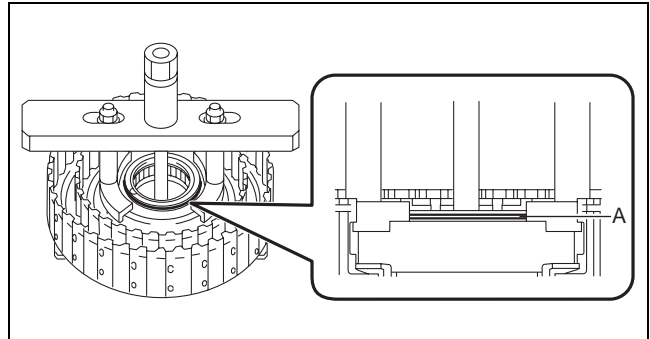

azzjw00000855

(5) Loosen the SST (49 G019 029) and remove the SSTs.

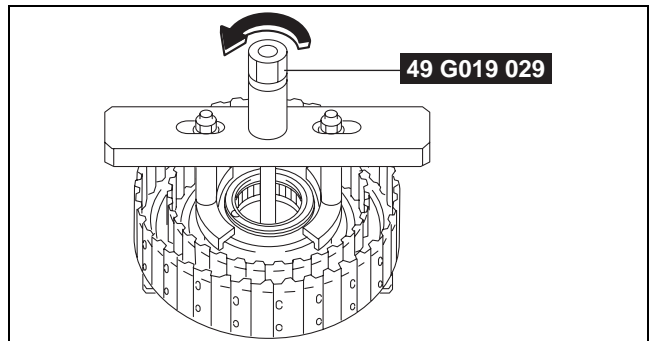

azzjw00000856

A : Nut included with SST (49 G019 025), or
M8×1.25 nut
B : Washer

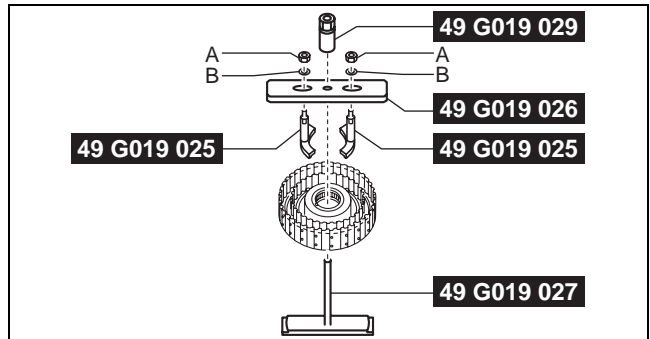

azzjw00000857

05-17

AUTOMATIC TRANSAXLE

5. Assemble the drive plates and driven plates using the following procedure:

Note

- Drive plate size: Outer diameter approx. 116.8 mm {4.598 in}
- Driven plate size: Inner diameter approx. 95.5 mm {3.76 in}

(1) Apply ATF (ATF FZ) to the drive plates and driven plates.

Caution

- If the drive plate is replaced with a new one, immerse it in ATF (ATF FZ) for 2 hours or more to permeate the facing with ATF.

(2) Assemble the drive plates and driven plates.

- A : Drive plate
B : Driven plate

Assembly order

Driven plate—drive plate—driven plate—drive plate—driven plate—drive plate—driven plate—drive plate—driven plate—drive plate

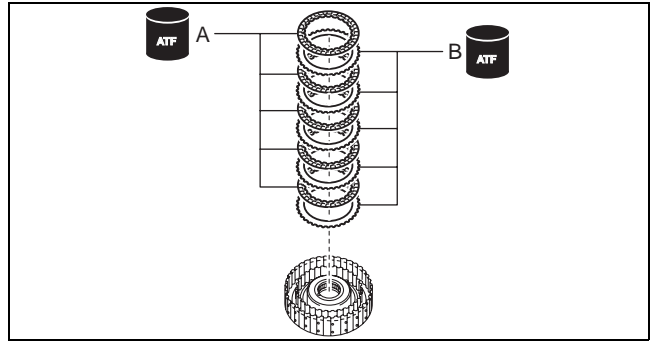

azzjiw00000858

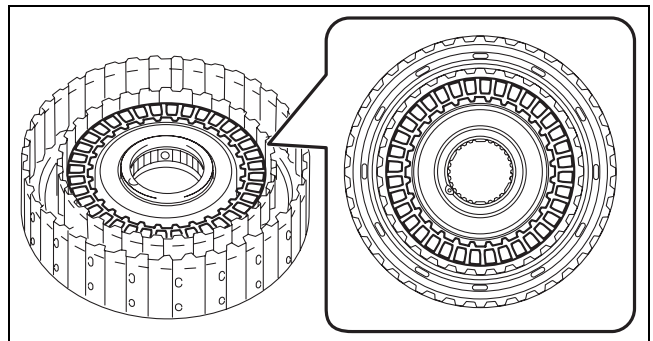

azzjiw00000859

6. Assemble the retaining plate.

Note

- Retaining plate size: Inner diameter approx. 95.5 mm {3.76 in}

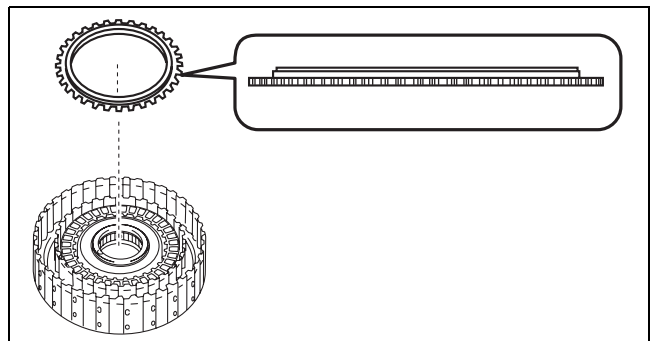

azzjiw00000860

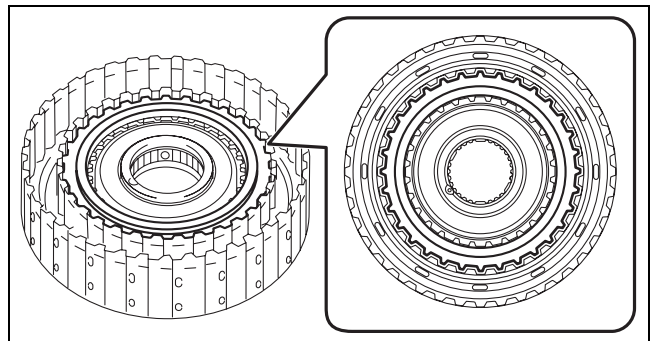

azzjiw00000861

AUTOMATIC TRANSAXLE

7. Assemble the snap ring using the following procedure:

Note

- Snap ring size: Outer diameter approx. 127.4 mm {5.016 in}

(1) Measure the high clutch clearance and select the appropriate snap ring. (See 05-17-317 HIGH CLUTCH CLEARANCE MEASUREMENT/ADJUSTMENT.)

Note

- If the snap ring is assembled for the high clutch clearance measurement/adjustment, the following snap ring assembly procedure is not necessary.

(2) Assemble the selected snap ring in Step (1).

A : Selection

Caution

- After assembling the snap ring, verify that the snap ring is securely inserted into the bottom of the snap ring groove.

05-17

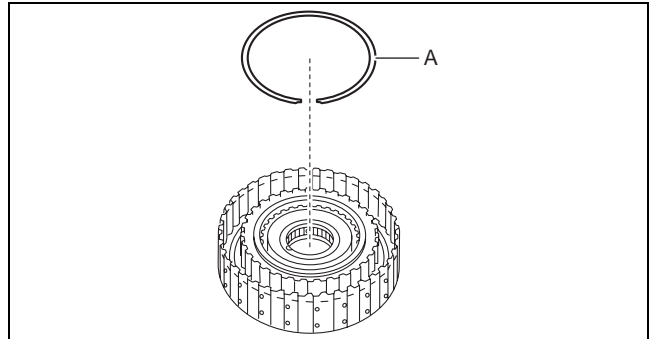

azzjw00000862

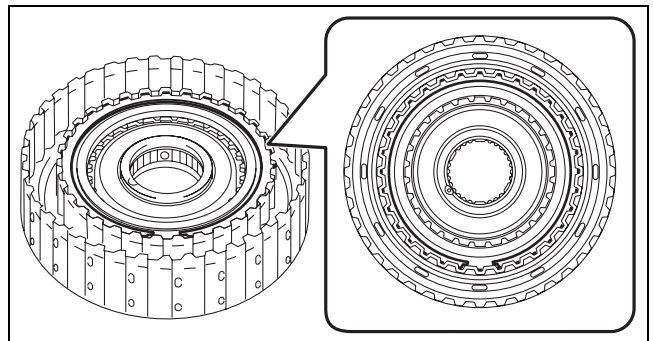

azzjw00000863

8. Assemble the wave spring.

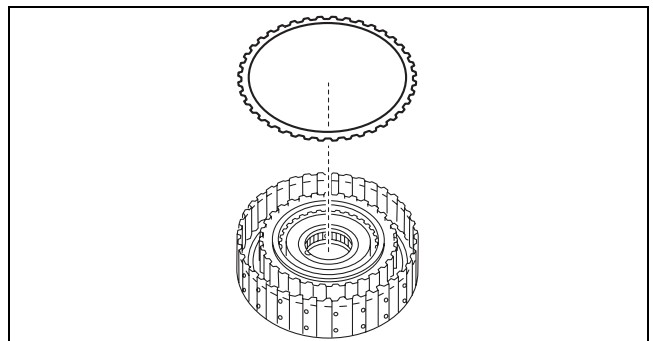

azzjw00000864

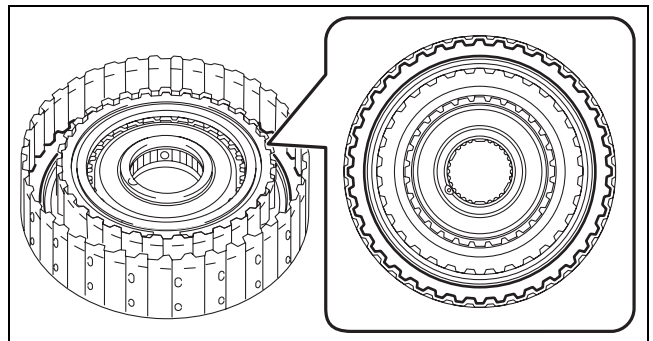

azzjw00000865

AUTOMATIC TRANSAXLE

9. Assemble the drive plates and driven plates using the following procedure:

Note

- Drive plate size: Outer diameter approx. 159.1 mm {6.264 in}
- Driven plate size: Inner diameter approx. 139.9 mm {5.508 in}

(1) Apply ATF (ATF FZ) to the drive plates and driven plates.

Caution

- If the drive plate is replaced with a new one, immerse it in ATF (ATF FZ) for 2 hours or more to permeate the facing with ATF.

(2) Assemble the drive plates and driven plates.

- A : Drive plate
B : Driven plate

Assembly order

Driven plate—drive plate—driven plate—drive plate—driven plate—drive plate—driven plate—drive plate—driven plate—drive plate

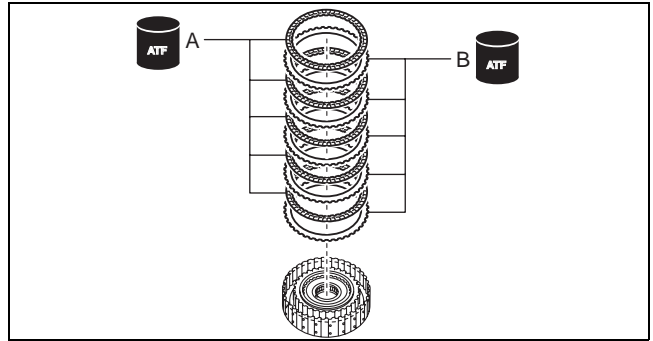

azzjiw00000866

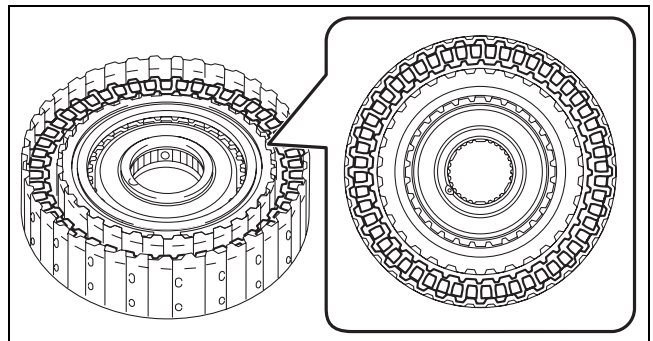

azzjiw00000867

10. Assemble the retaining plate.

Note

- Retaining plate size: Inner diameter approx. 139.9 mm {5.508 in}

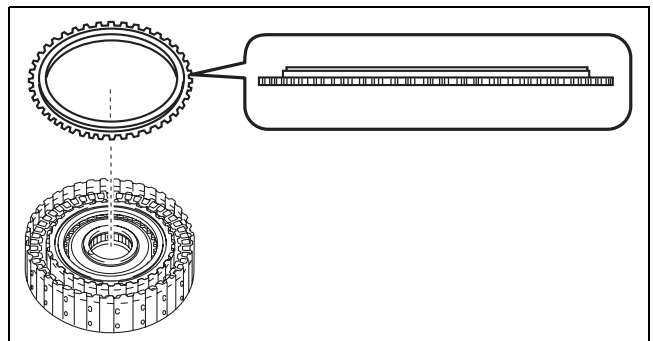

azzjiw00000868

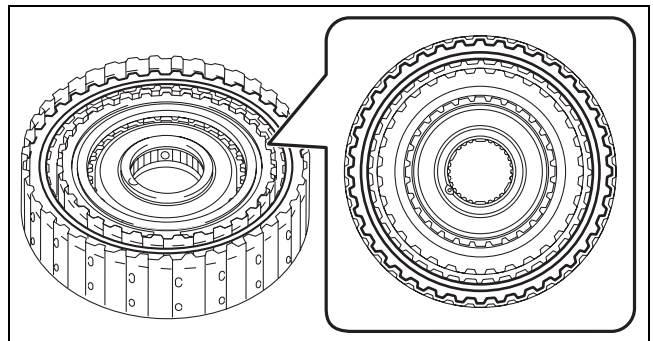

azzjiw00000869

AUTOMATIC TRANSAXLE

11. Assemble the snap ring using the following procedure:

Note

- Snap ring size: Outer diameter approx. 169.3 mm {6.665 in}

(1) Measure the low clutch clearance and select the appropriate snap ring. (See 05-17-327 LOW CLUTCH CLEARANCE MEASUREMENT/ADJUSTMENT.)

Note

- If the snap ring is assembled for the low clutch clearance measurement/adjustment, the following snap ring assembly procedure is not necessary.

(2) Assemble the selected snap ring in Step (1) to the position shown in the figure.

A : Selection

Caution

- Assemble so that the end gap of the snap ring is positioned diagonally opposed to the end gap of the snap ring for the high clutch.
- After assembling the snap ring, verify that the snap ring is securely inserted into the bottom of the snap ring groove.

A : Snap ring (low clutch)

B : Snap ring (high clutch)

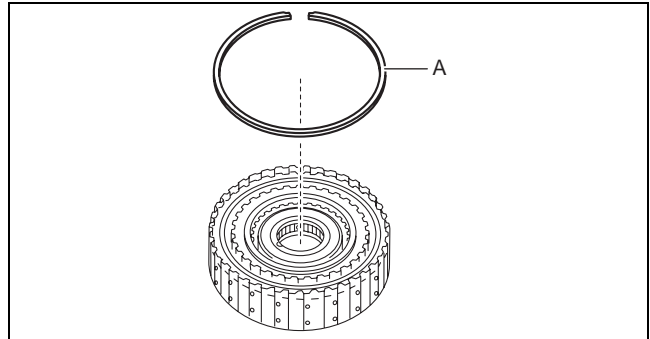

azzjjw00000870

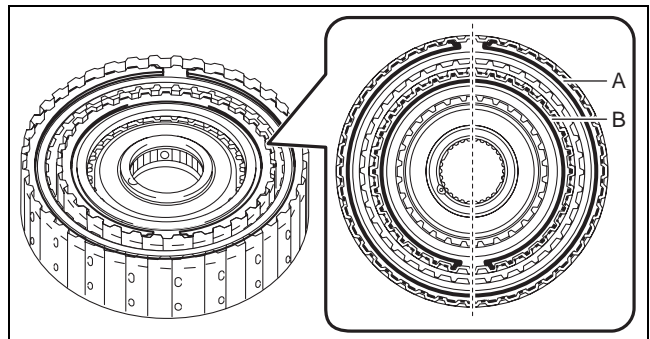

azzjjw00000871

12. Perform a simple inspection of the low clutch and high clutch using the following procedure:

(1) Set the oil pump on the workbench as shown in the figure.

A : Rubber plate

Note

- Using the rubber plates, adjust the alignment surface of the oil pump with the transaxle case so that it is level.

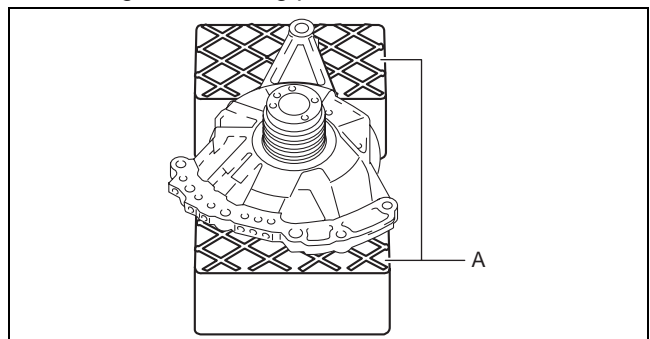

azzjjw00000802

AUTOMATIC TRANSAXLE

(2) Assemble the thrust needle bearing to the clutch component using the following procedure:

Note

- Thrust needle bearing size: Outer diameter approx. 72.7 mm {2.86 in}
- 1) To prevent the thrust needle bearing from dropping out, apply ATF (ATF FZ) to the thrust needle bearing.
 - 2) Assemble the thrust needle bearing.

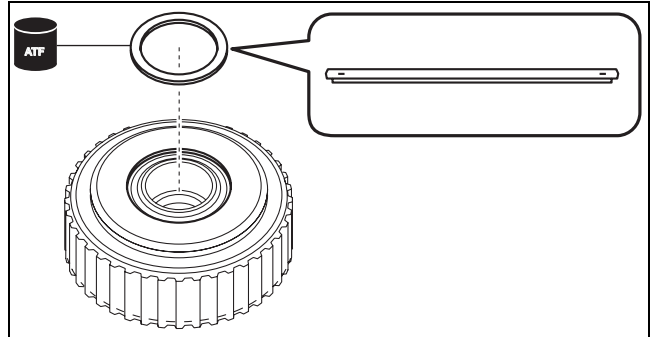

azzjw00000803

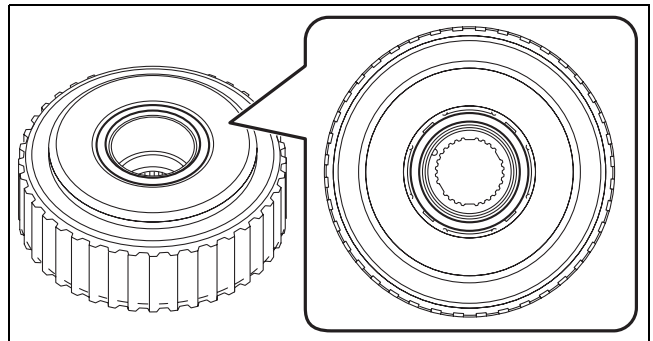

azzjw00000804

(3) Assemble the parts assembled together in Step (2) to the oil pump.

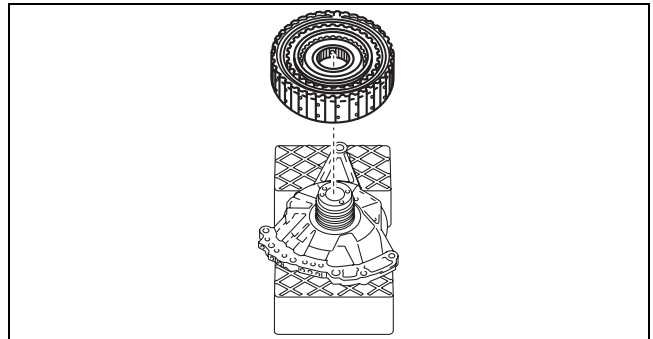

azzjw00000805

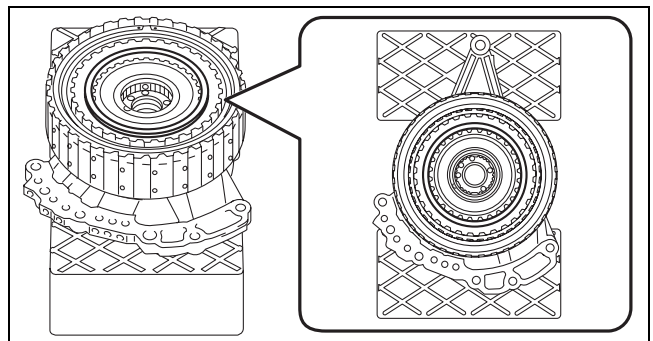

azzjw00000806

AUTOMATIC TRANSAXLE

- (4) Blow compressed air into the oil passage shown in the figure and verify the operation condition of the low clutch.

Warning

- Always wear protective eye wear when using the air compressor. Otherwise, ATF or dirt particles blown off by the air compressor could get into the eyes.

Caution

- To prevent damage to parts, always use an air compressor which is adjusted to the indicated pressure.

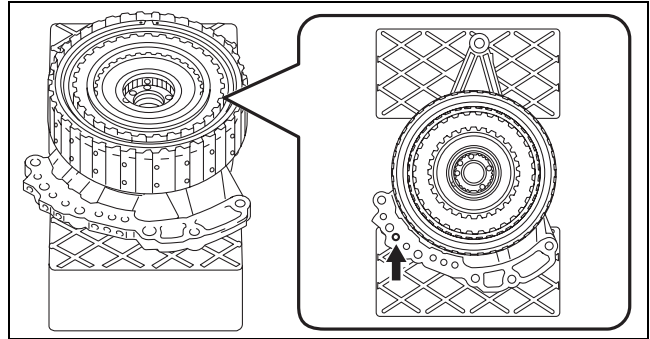

azzjw00000807

05-17

Compressed air pressure

0.39—0.44 MPa {4.0—4.4 kgf/cm², 57—63 psi}

- If there is a malfunction, perform disassembly again, verify the cause and repair the applicable part. (See 05-17-104 CLUTCH COMPONENT DISASSEMBLY.)

- (5) Blow compressed air into the oil passage shown in the figure and verify the operation condition of the high clutch.

Warning

- Always wear protective eye wear when using the air compressor. Otherwise, ATF or dirt particles blown off by the air compressor could get into the eyes.

Caution

- To prevent damage to parts, always use an air compressor which is adjusted to the indicated pressure.

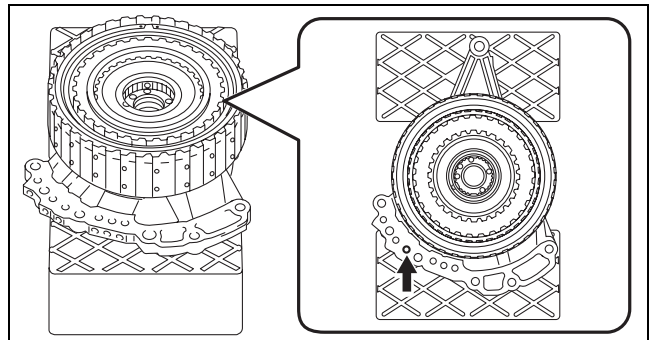

azzjw00000808

Compressed air pressure

0.39—0.44 MPa {4.0—4.4 kgf/cm², 57—63 psi}

- If there is a malfunction, perform disassembly again, verify the cause and repair the applicable part. (See 05-17-104 CLUTCH COMPONENT DISASSEMBLY.)

AUTOMATIC TRANSAXLE

(6) Remove the clutch component.

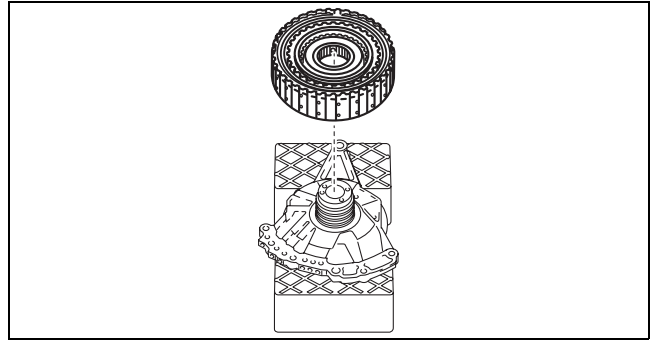

azzijw00000809

(7) Remove the thrust needle bearing.

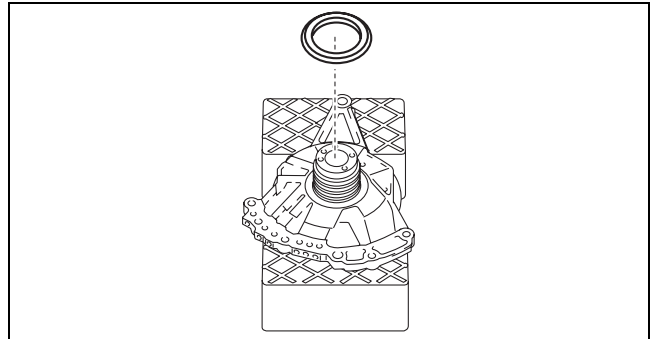

azzijw00000810

(8) Take the oil pump off the rubber plates.

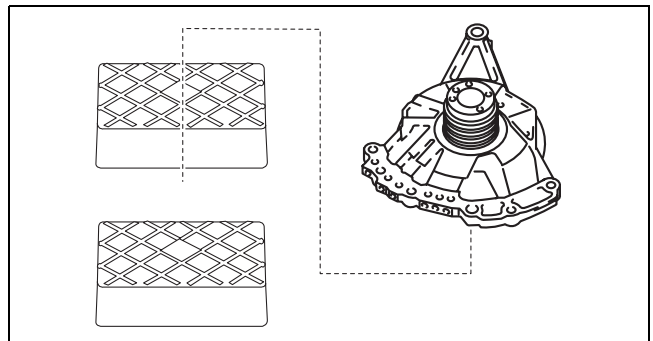

azzijw00001258

AUTOMATIC TRANSAXLE

REAR PLANETARY GEAR ASSEMBLY

id051700663800

Structural View

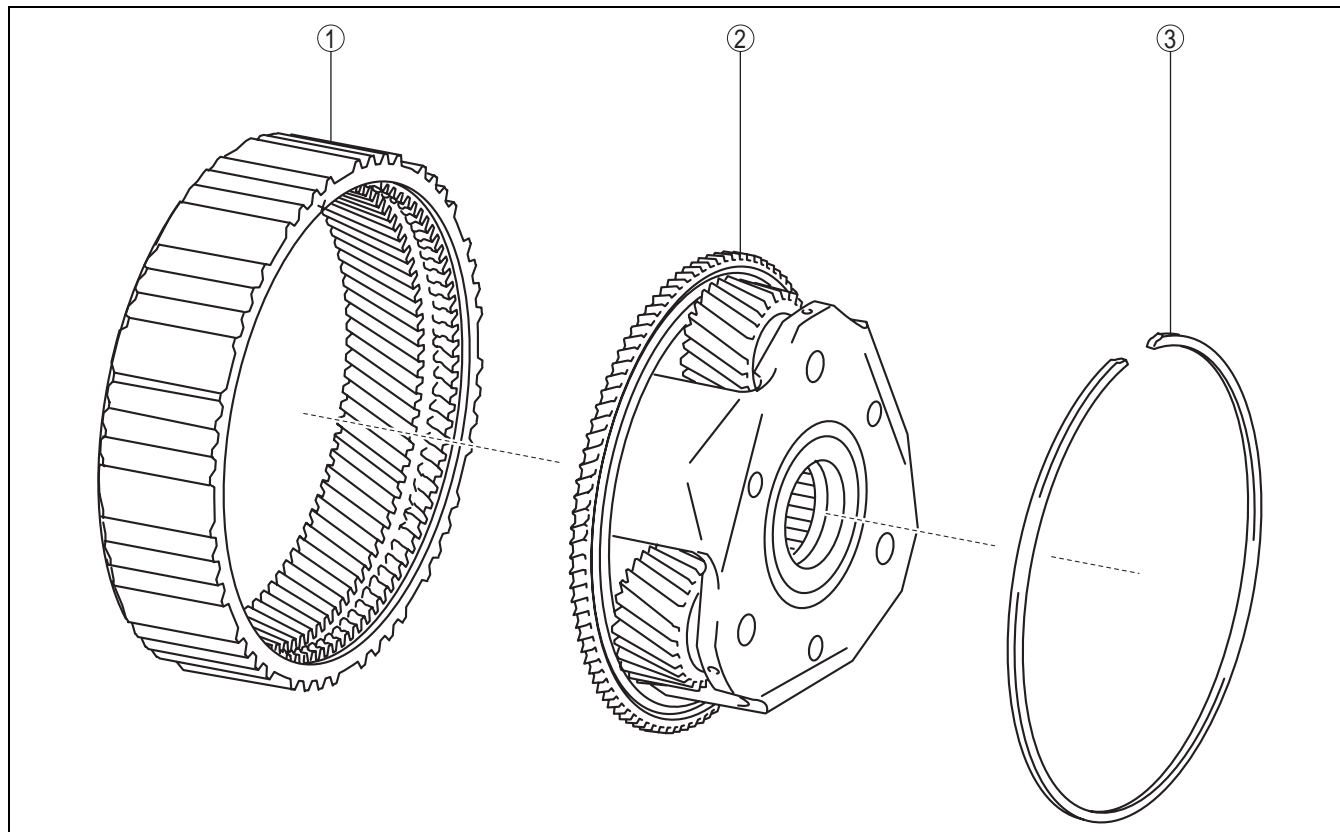

05-17

azzijw00000293

1	Front internal gear
2	Rear planetary carrier

3	Snap ring (outer diameter approx. 135.6 mm {5.339 in})
---	--

AUTOMATIC TRANSAXLE

Assembly Procedure

1. Assemble the rear planetary carrier.

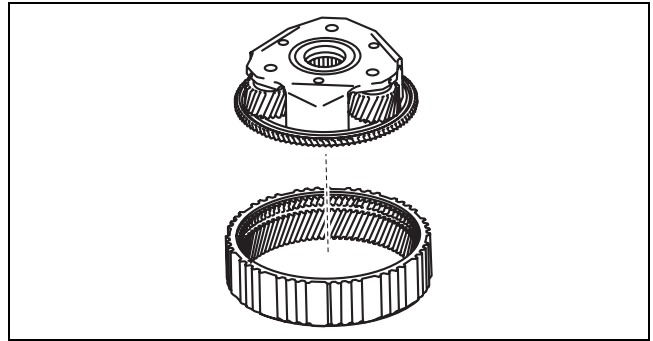

azzjw00000874

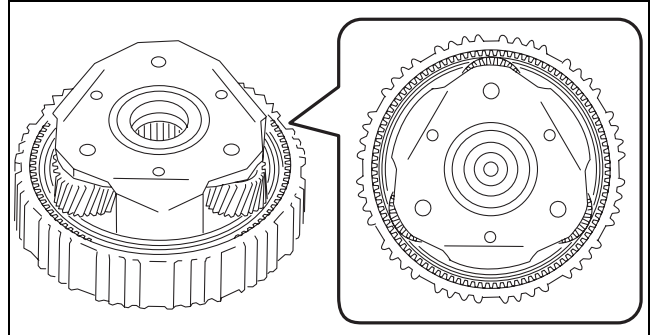

azzjw00000875

2. Assemble the snap ring.

Caution

- After assembling the snap ring, verify that the snap ring is securely inserted into the bottom of the snap ring groove.

Note

- Snap ring size: Outer diameter approx. 135.6 mm {5.339 in}

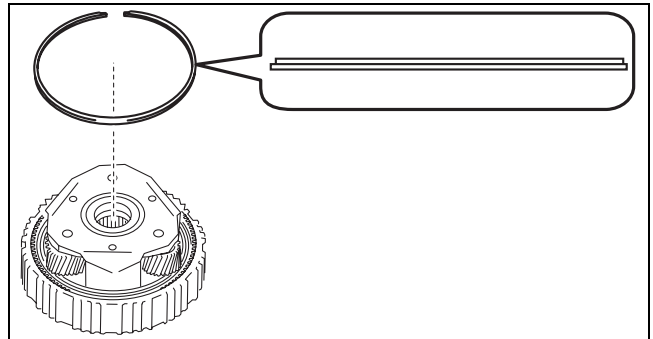

azzjw00000876

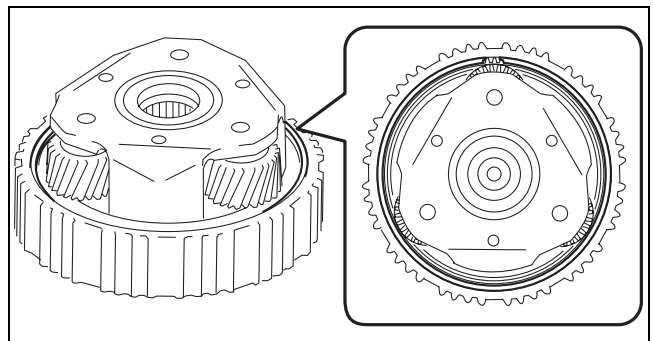

azzjw00000877

AUTOMATIC TRANSAXLE

REDUCTION PLANETARY GEAR ASSEMBLY

id051700663900

Structural View

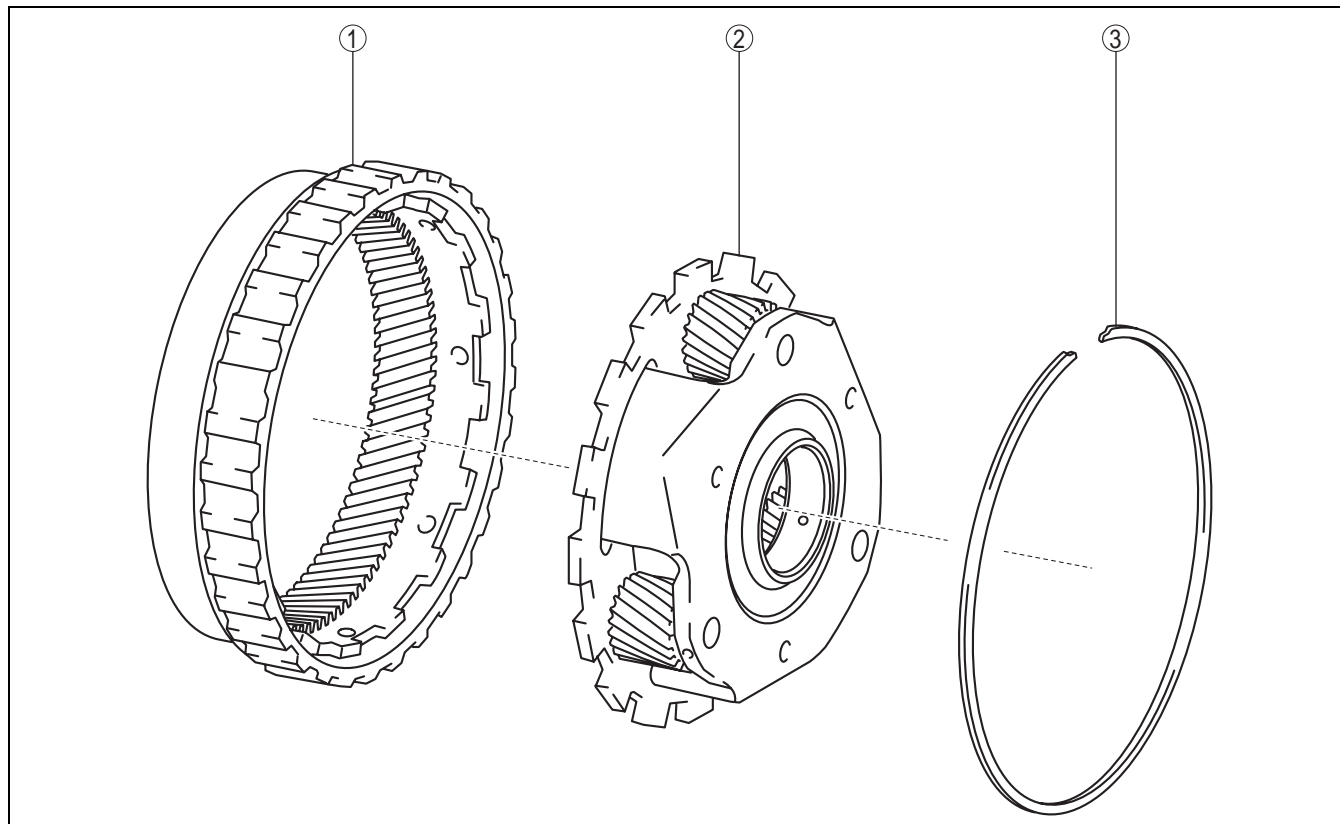

azzjw00000297

1	Rear internal gear
2	Reduction planetary carrier

3	Snap ring (outer diameter approx. 142.5 mm {5.610 in})
---	--

05-17

AUTOMATIC TRANSAXLE

Assembly Procedure

1. Assemble the reduction planetary carrier.

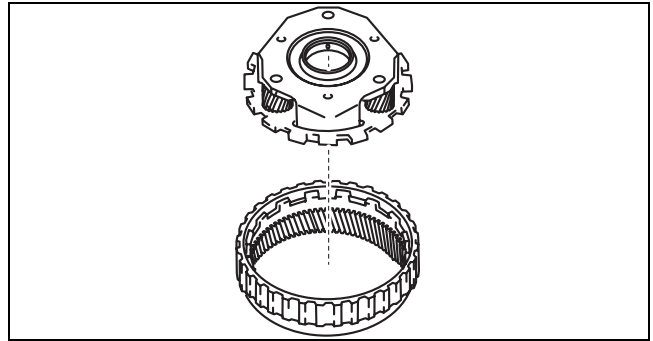

azzjw00000878

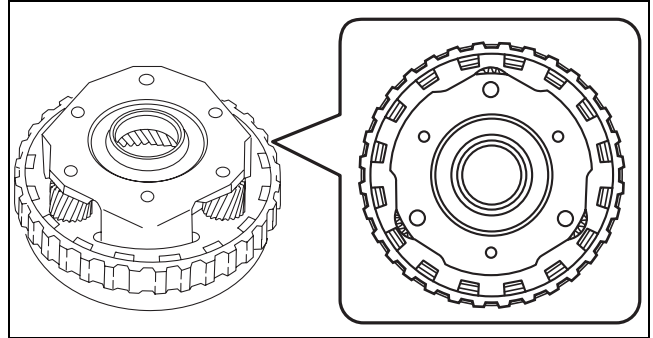

azzjw00000879

2. Assemble the snap ring.

Caution

- After assembling the snap ring, verify that the snap ring is securely inserted into the bottom of the snap ring groove.

Note

- Snap ring size: Outer diameter approx. 142.5 mm {5.610 in}

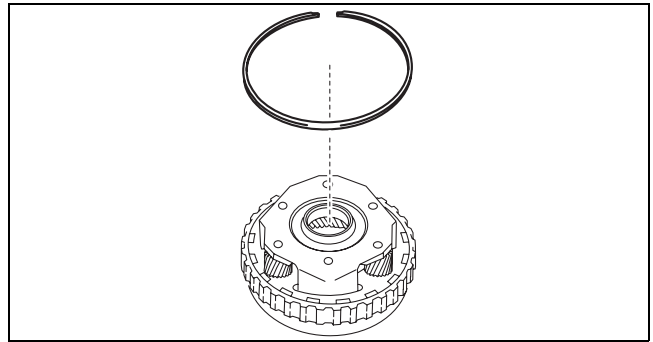

azzjw00000880

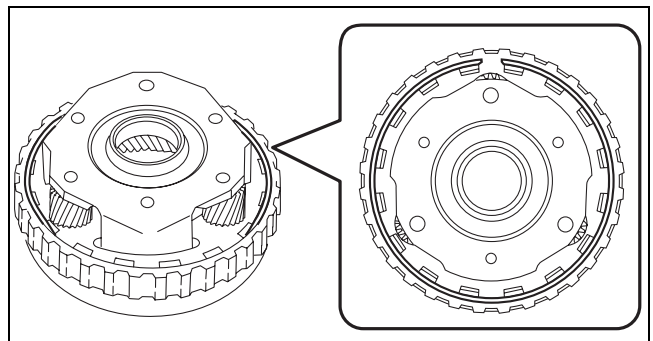

azzjw00000881

AUTOMATIC TRANSAXLE

SECONDARY GEAR AND OUTPUT GEAR ASSEMBLY

id051700664000

Structural View

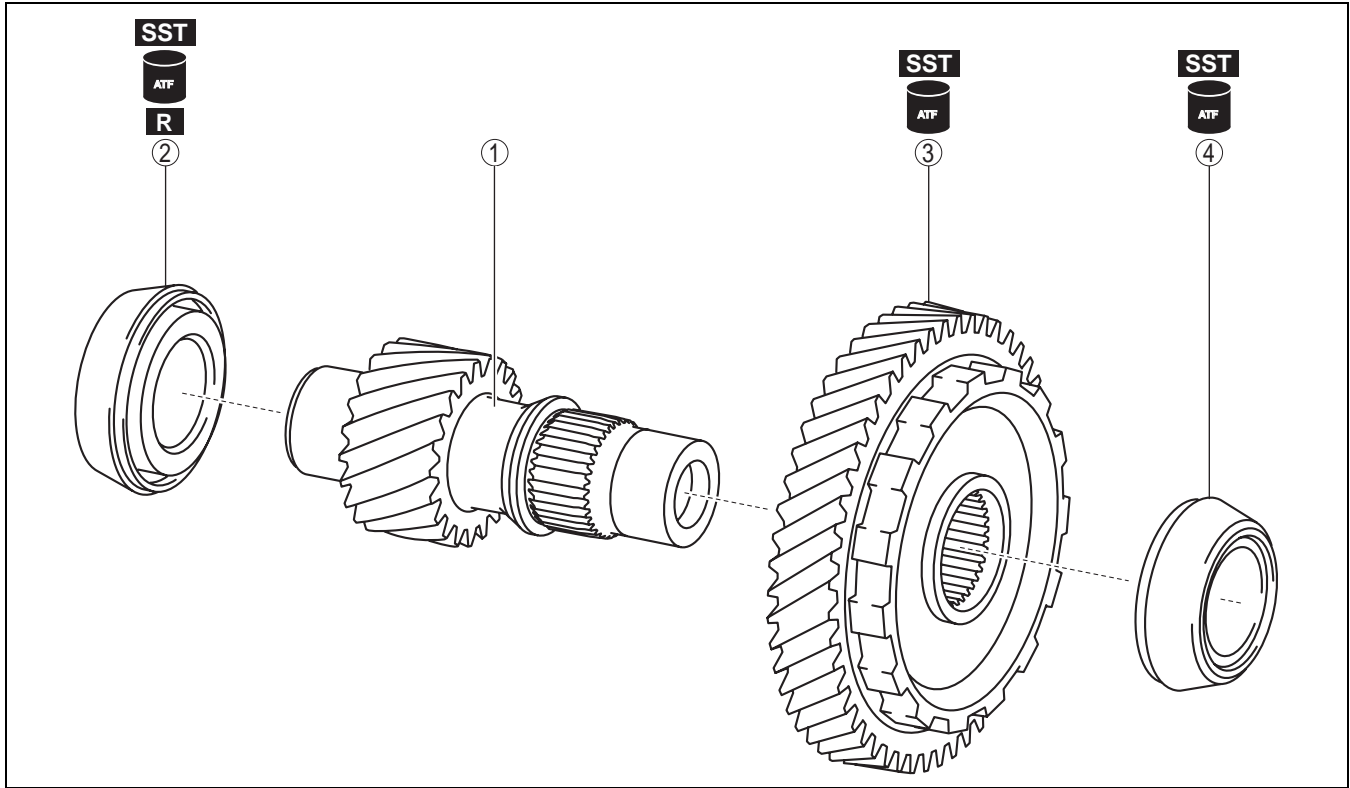

05-17

azzjjw00001533

1	Output gear
2	Taper roller bearing (converter housing side) (inner diameter 35.5 mm {1.398 in})

3	Secondary gear
4	Taper roller bearing (transaxle case side) (inner diameter 35 mm {1.378 in})

AUTOMATIC TRANSAXLE

Assembly Procedure

1. Assemble a new taper roller bearing (converter housing side) using the following procedure:

Caution

- Use a new taper roller bearing. If taper roller bearing with a deformed cage are reused, it may cause a transaxle malfunction.

Note

- Taper roller bearing size: Inner diameter approx. 35.5 mm {1.398 in}

- (1) Apply ATF (ATF FZ) to the engagement area of the new taper roller bearing and output gear.
- (2) Using the SST and press, assemble the new taper roller bearing.

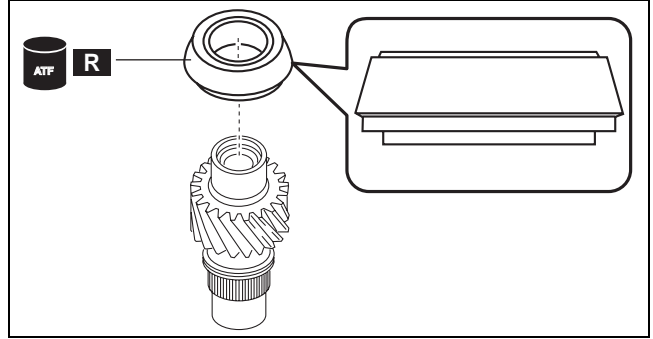

azzjw0000993

A : Press

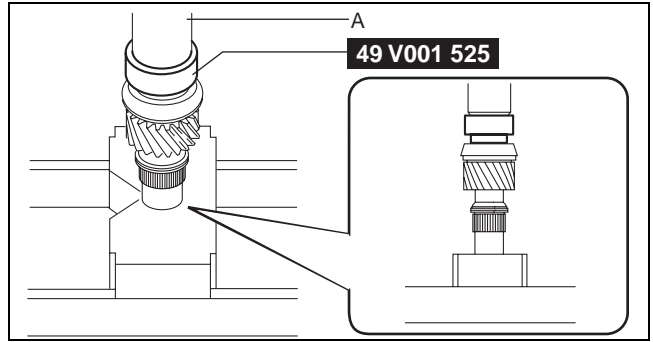

azzjw0000994

AUTOMATIC TRANSAXLE

2. Assemble the secondary gear using the following procedure:

- (1) Apply ATF (ATF FZ) to the engagement area (spline area) of the secondary gear and output gear.
- (2) Using the SST and press, assemble the secondary gear.

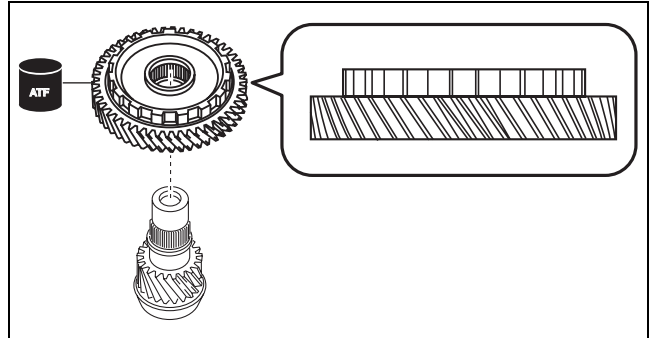

azzjw00000995

A : Press

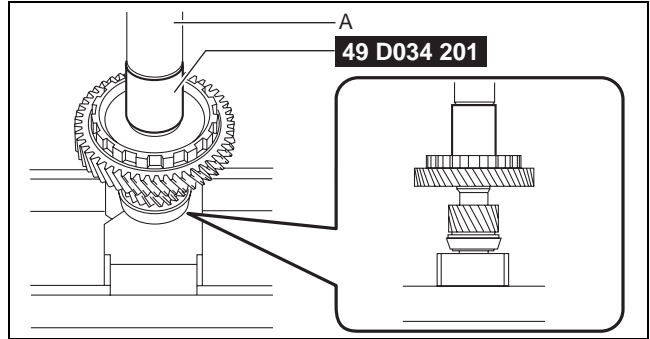

azzjw00000996

3. Assemble the taper roller bearing (transaxle case side) using the following procedure:

Note

- Taper roller bearing size: Inner diameter approx. 35 mm {1.378 in}

- (1) Apply ATF (ATF FZ) to the engagement area of the taper roller bearing and output gear.
- (2) Using the SST and press, assemble the taper roller bearing.

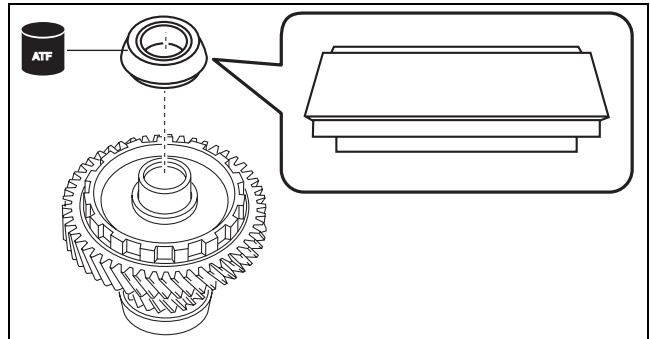

azzjw00000997

A : Press

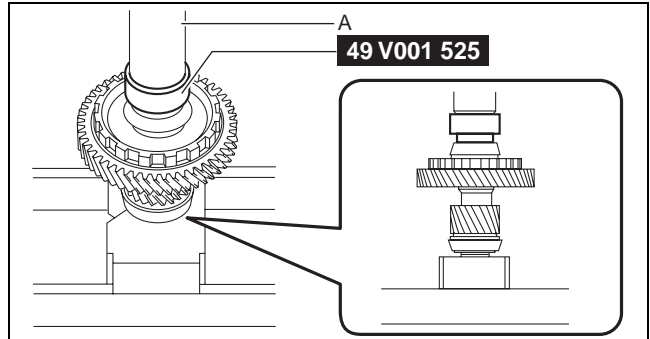

azzjw00000998

AUTOMATIC TRANSAXLE

RING GEAR AND DIFFERENTIAL ASSEMBLY

id051700664100

Structural View

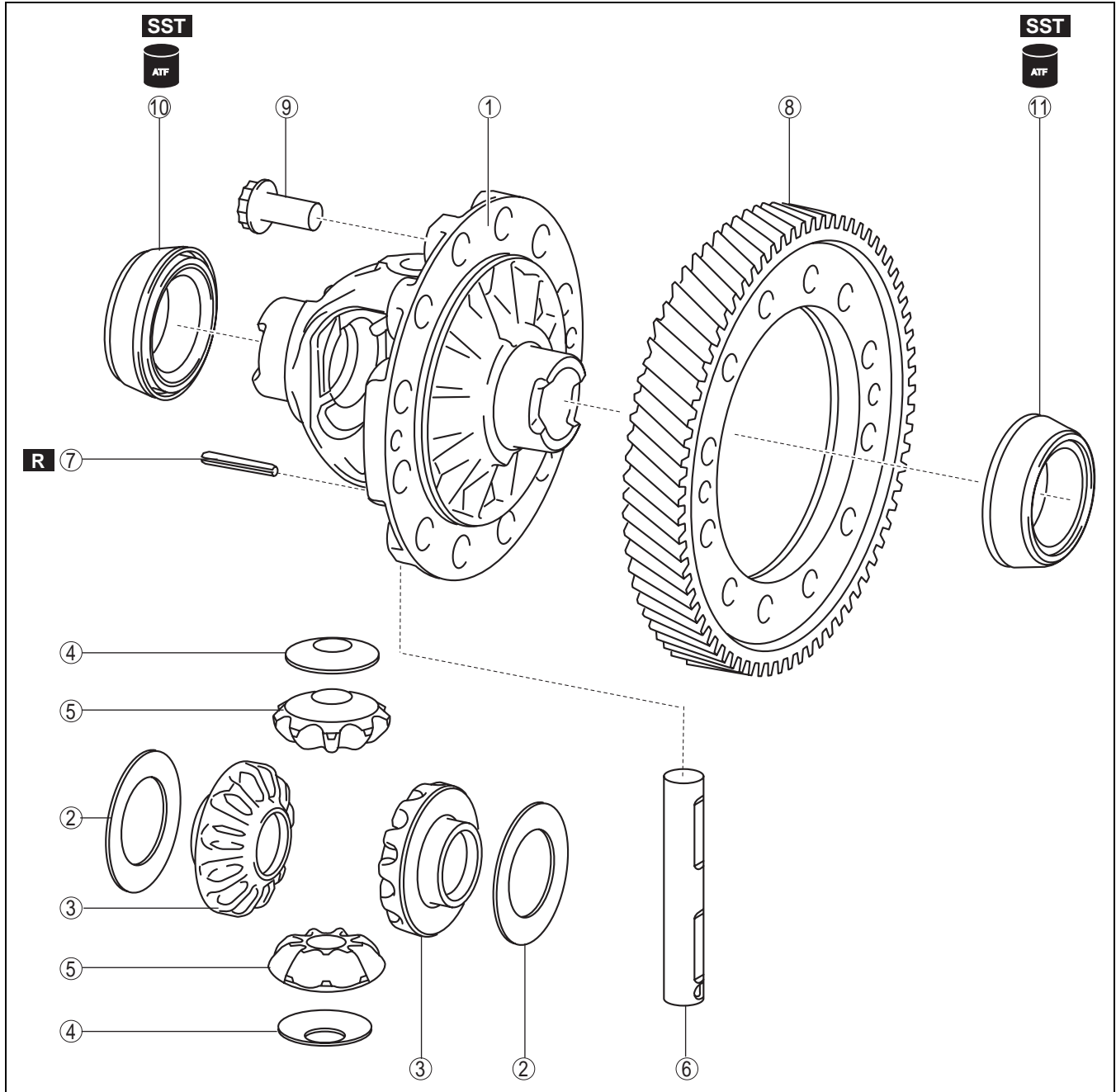

azzjiw00001534

1	Differential gear case
2	Thrust washer (selection)
3	Side gear
4	Thrust washer
5	Pinion gear
6	Pinion shaft
7	Roll pin

8	Ring gear
9	12 bolts (M13×1.0 bolt, length to approx. 26.2 mm {1.03 in})
10	Taper roller bearing (converter housing side) (inner diameter approx. 45 mm {1.8 in})
11	Taper roller bearing (transaxle case side) (inner diameter approx. 45 mm {1.8 in})

AUTOMATIC TRANSAXLE

Assembly Procedure

1. Assemble the thrust washers to the side gears.

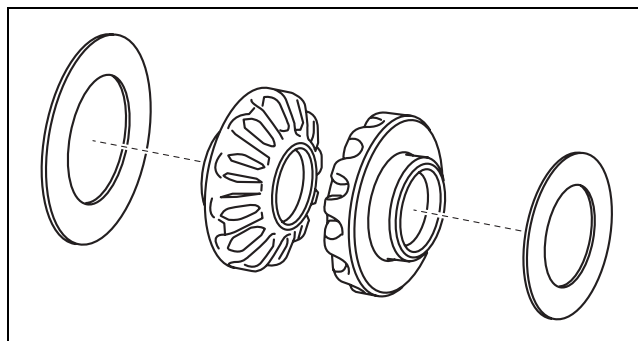

azzjw00001535

05-17

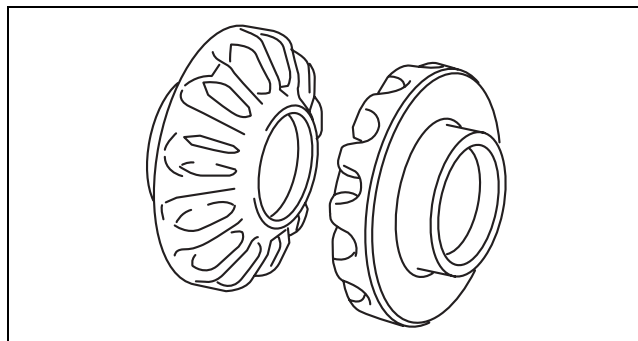

azzjw00001536

2. Assemble the side gears which have the thrust washers assembled to them.

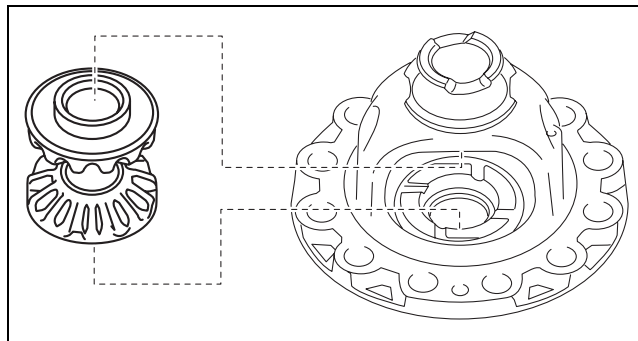

azzjw00001537

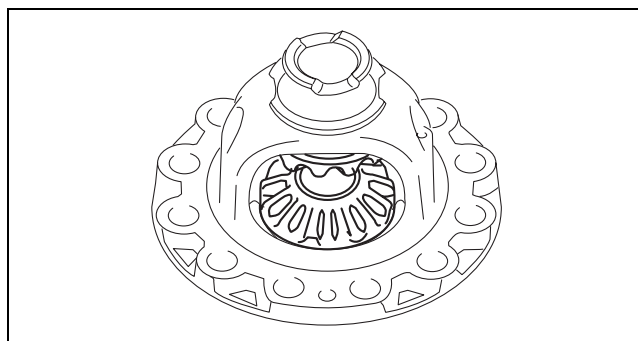

azzjw00001538

AUTOMATIC TRANSAXLE

3. Assemble the thrust washers to the pinion gears.

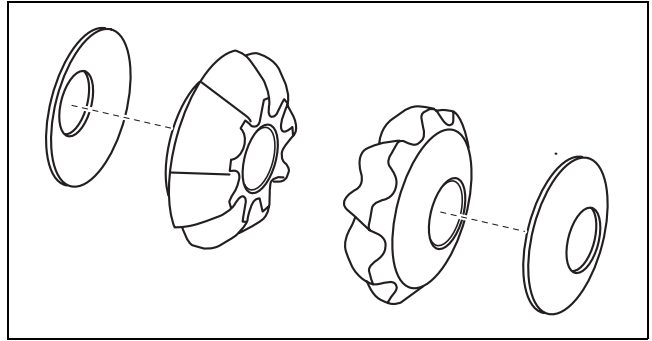

azzijw00001539

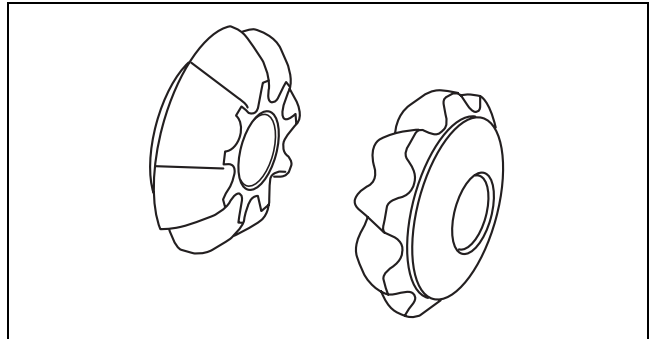

azzijw00001540

4. Assemble the pinion gears which have the thrust washers assembled to them using the following procedure:

(1) Assemble the pinion gears which have the thrust washers assembled to them.

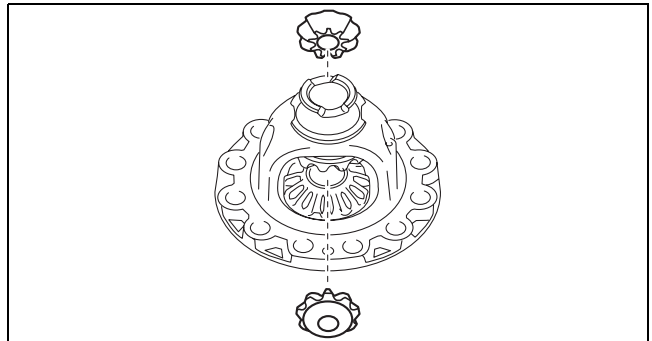

azzijw00001541

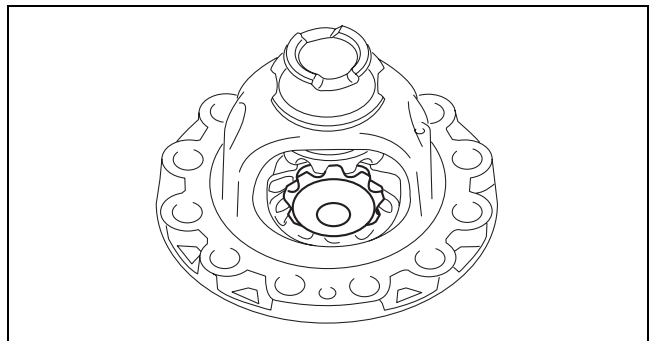

azzijw00001542

AUTOMATIC TRANSAXLE

- (2) Rotate the pinion gears so that the pinion shaft holes of the differential gear case and the pinion gears are aligned as shown in the figure.

Note

- If the pinion shaft holes of the differential gear case and the pinion gears are not aligned, remove the pinion gears, change the side gears combination, and reassemble.

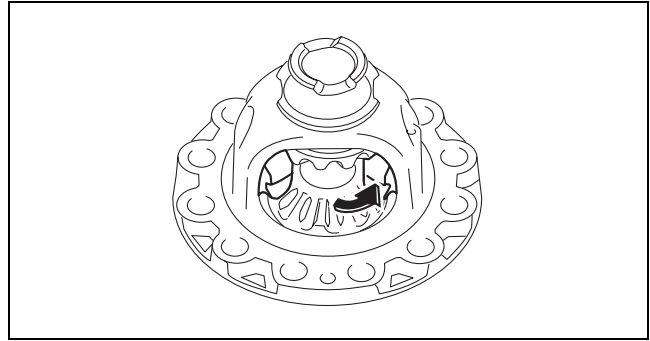

azzjw00001543

05-17

5. Assemble the pinion shaft.

Caution

- Assemble the pinion shaft so that the roll pin holes of the differential gear case and the pinion shaft are aligned.

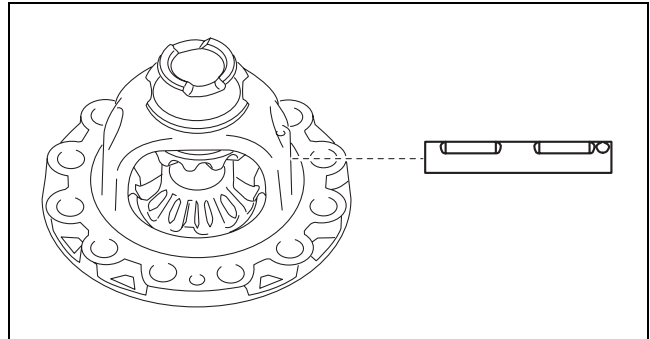

azzjw00001544

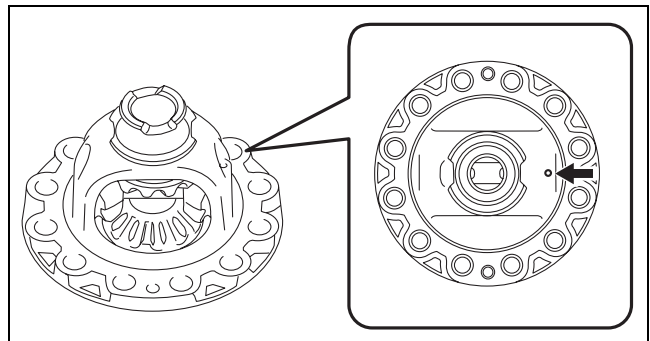

azzjw00001545

6. Assemble a new roll pin to the position shown in the figure using a pin punch.

Caution

- Assemble so that the end gap of the roll pin is positioned in the direction shown in the figure.

Note

- Use a pin punch with an end outer diameter of 5 mm {0.197 in} or more, and within 8 mm {0.314 in}.

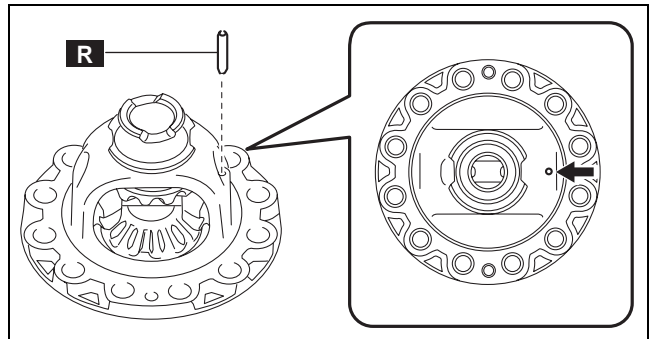

azzjw00001546

A : -0.5—0.5 mm {-0.01—0.01 in}

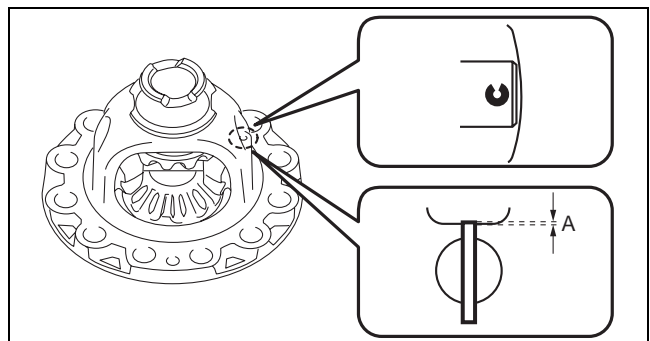

azzjw00001547

AUTOMATIC TRANSAXLE

7. Assemble the ring gear using the following procedure:

1	Ring gear
2	12 bolts (M13×1.0 bolt, length to approx. 26.2 mm {1.03 in})

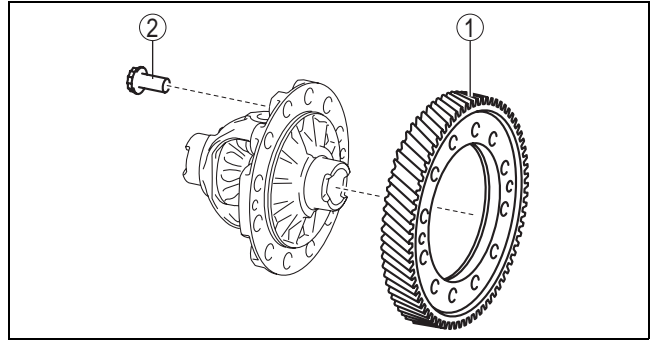

azzjiw00001000

(1) Assemble the ring gear.

Note

- Assemble the ring gear so that the differential holes and ring gear holes shown in the figure are aligned.

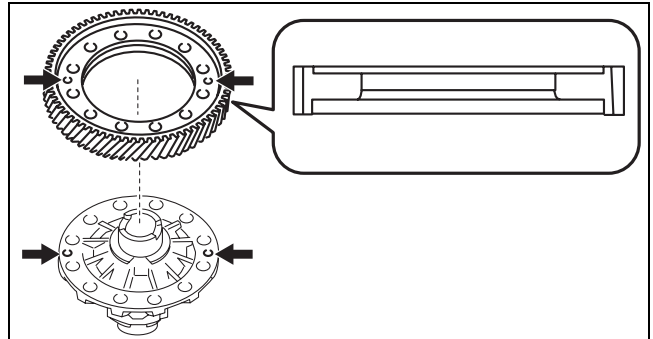

azzjiw00001001

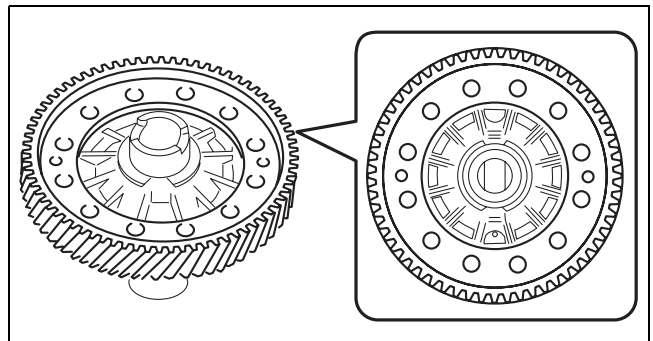

azzjiw00001002

(2) Assemble and temporarily tighten the bolts to the positions shown in the figure.

Note

- Bolt size: M13×1.0 bolt, length to approx. 26.2 mm {1.03 in}

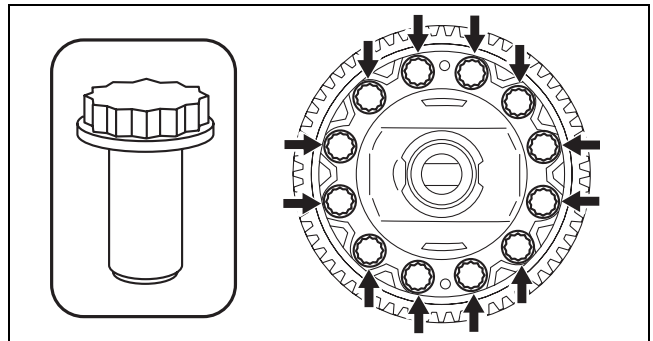

azzjiw00001003

(3) Secure the ring gear and differential in a vise.

A : Vise

Caution

- Insert a protective plate between the vise and the part so as not to damage the part.

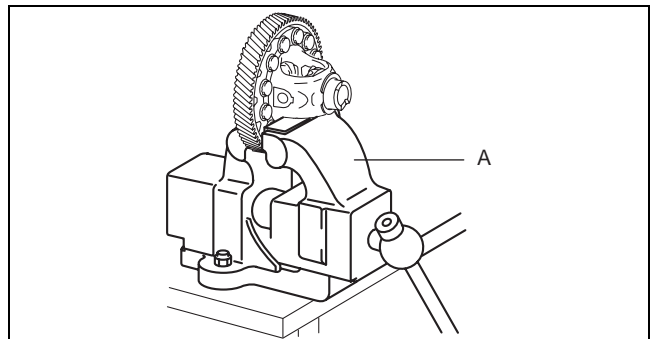

azzjiw00001004

AUTOMATIC TRANSAXLE

(4) Tighten the bolts shown in the figure.

Note

- Change the vise securing position of the ring gear and differential and tighten all of the bolts shown in the figure.

Tightening torque

152—176 N·m {16—17 kgf·m, 113—129 ft·lbf}

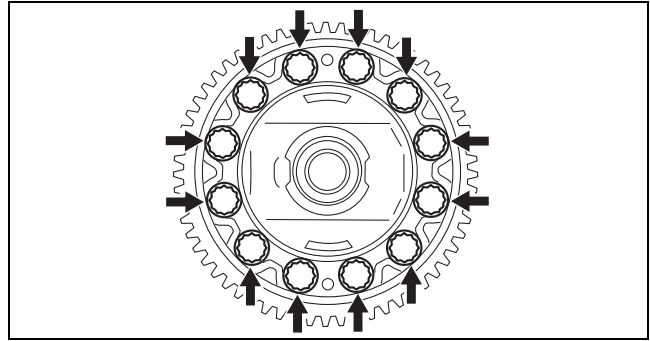

azzjjw00001005

05-17

(5) Remove the ring gear and differential from the vise.

A : Vise

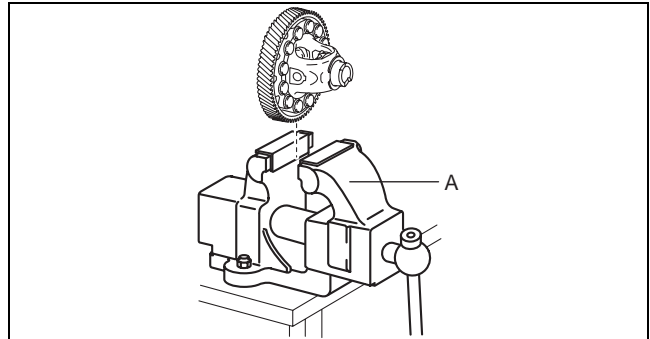

azzjjw00001006

8. Assemble the taper roller bearing (converter housing side) using the following procedure:

Note

- Taper roller bearing size: Inner diameter approx. 45 mm {1.8 in}

- (1) Apply ATF (ATF FZ) to the engagement area of the taper roller bearing and differential.
- (2) Using the SST and press, assemble the taper roller bearing.

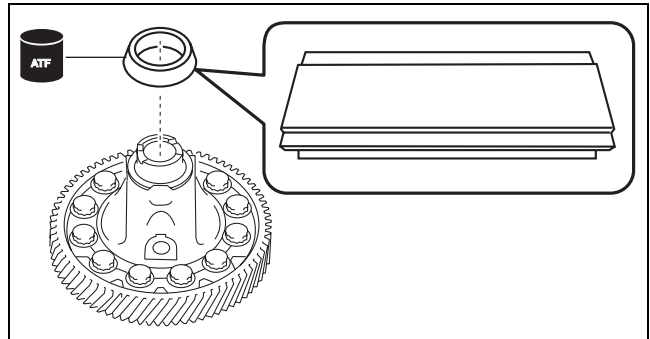

azzjjw00001007

A : Press

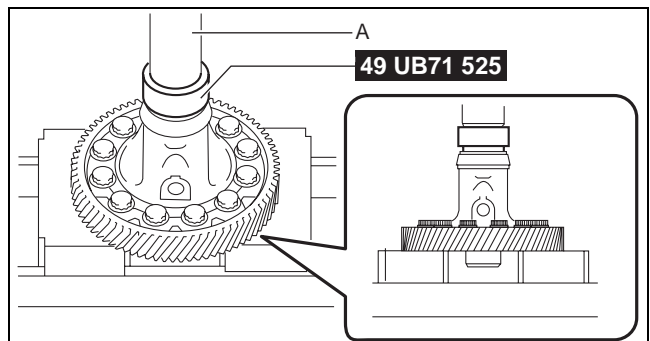

azzjjw00001008

AUTOMATIC TRANSAXLE

9. Assemble the taper roller bearing (transaxle case side) using the following procedure:

Note

- Taper roller bearing size: Inner diameter approx. 45 mm {1.8 in}

- (1) Apply ATF (ATF FZ) to the engagement area of the taper roller bearing and differential.
- (2) Using the SST and press, assemble the taper roller bearing.

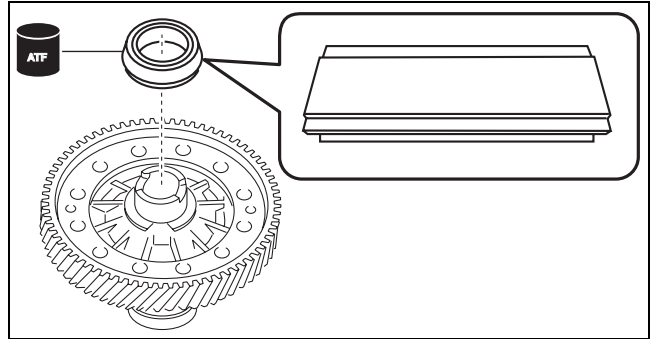

azzjw00001009

A : Press

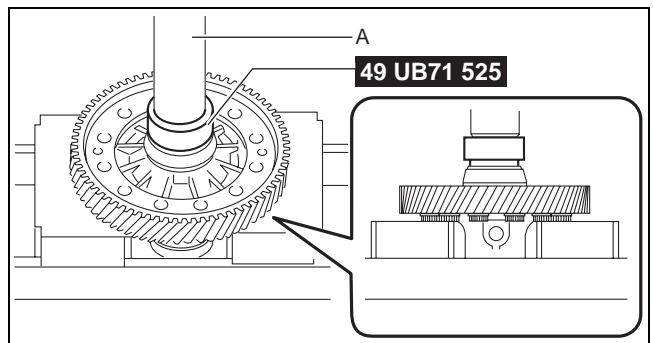

azzjw00001010

10. Perform the differential backlash measurement/adjustment. (See 05-17-303 DIFFERENTIAL BACKLASH MEASUREMENT/ADJUSTMENT.)

AUTOMATIC TRANSAXLE

END COVER COMPONENT ASSEMBLY

id051700664200

Structural View

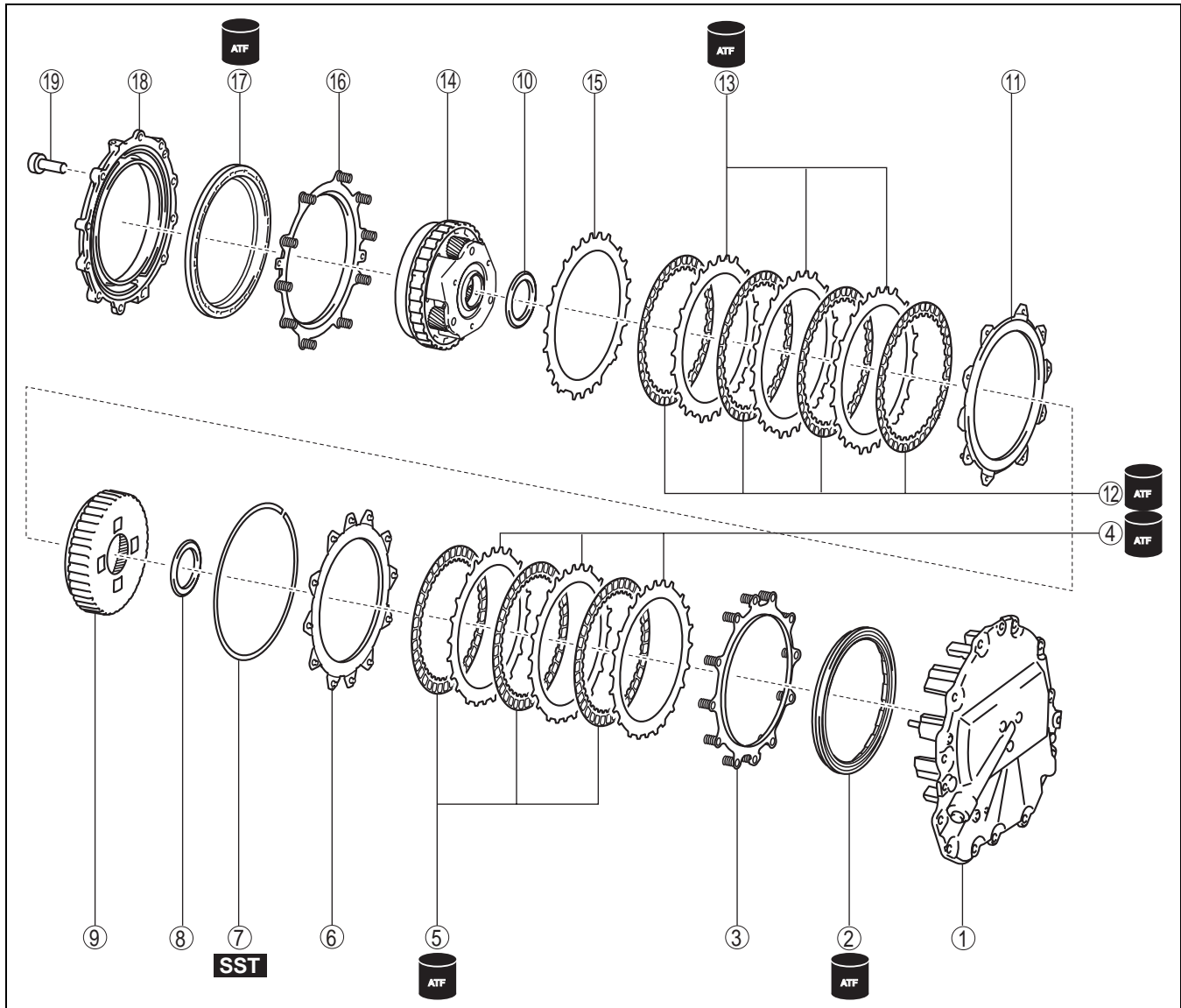

05-17

azzjjw00001548

1	End cover
2	R-3-5 brake piston
3	Springs and retainer component (inner diameter approx. 148.8 mm {5.858 in})
4	Driven plate (inner diameter approx. 141.8 mm {5.583 in})
5	Drive plate (outer diameter approx. 169.4 mm {6.669 in})
6	Retaining plate (inner diameter approx. 141.8 mm {5.583 in})
7	Snap ring (outer diameter approx. 186.2 mm {7.331 in}) (selection)
8	Thrust needle bearing (outer diameter approx. 63 mm {2.5 in})
9	Reduction internal gear
10	Thrust needle bearing (outer diameter approx. 63 mm {2.5 in})

11	Retaining plate (inner diameter approx. 148 mm {5.83 in})
12	Drive plate (outer diameter approx. 171.9 mm {6.768 in})
13	Driven plate (outer diameter approx. 148 mm {5.83 in}, thickness approx. 1.6 mm {0.063 in})
14	Reduction planetary gear
15	Retaining plate (inner diameter approx. 148 mm {5.83 in}) (selection)
16	Springs and retainer component (inner diameter approx. 150.6 mm {5.929 in})
17	2-6 brake piston
18	Brake housing
19	8 bolts (M6×1.0 bolt, length to approx. 25 mm {0.98 in})

AUTOMATIC TRANSAXLE

Assembly Procedure

1. Assemble the R-3-5 brake piston using the following procedure:
 - (1) Apply ATF (ATF FZ) to the R-3-5 brake piston lip.
 - (2) Assemble the R-3-5 brake piston.

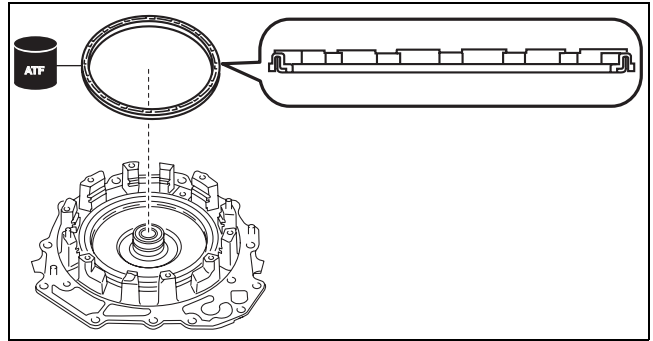

azzjw00001012

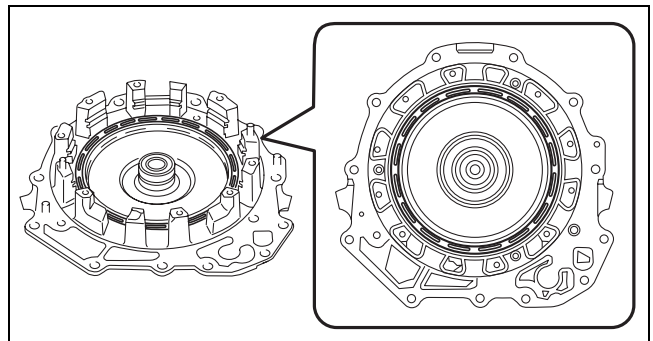

azzjw00001013

2. Measure the R-3-5 brake clearance and select the appropriate snap ring. (See 05-17-339 R-3-5 BRAKE CLEARANCE MEASUREMENT/ADJUSTMENT.)
3. Assemble the springs and retainer component.

Note

- Springs and retainer component size: Inner diameter approx. 148.8 mm {5.858 in}

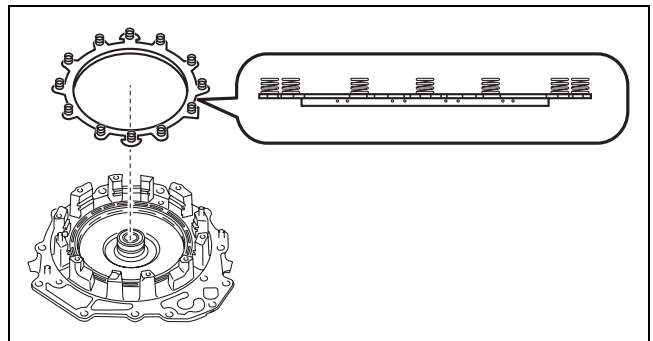

azzjw00001014

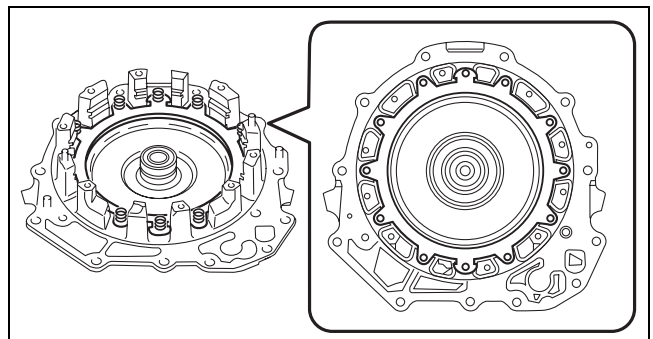

azzjw00001015

AUTOMATIC TRANSAXLE

4. Assemble the drive plates and driven plates using the following procedure:

Note

- Drive plate size: Outer diameter approx. 169.4 mm {6.669 in}
- Driven plate size: Inner diameter approx. 141.8 mm {5.583 in}

(1) Apply ATF (ATF FZ) to the drive plates and driven plates.

Caution

- If the drive plate is replaced with a new one, immerse it in ATF (ATF FZ) for 2 hours or more to permeate the facing with ATF.

(2) Assemble the drive plates and driven plates.

- A : Drive plate
B : Driven plate

Assembly order

Driven plate—drive plate—driven plate—drive plate—driven plate—drive plate

05-17

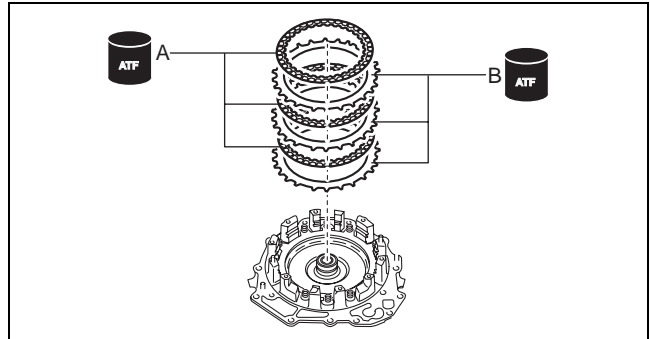

azzjjw00001016

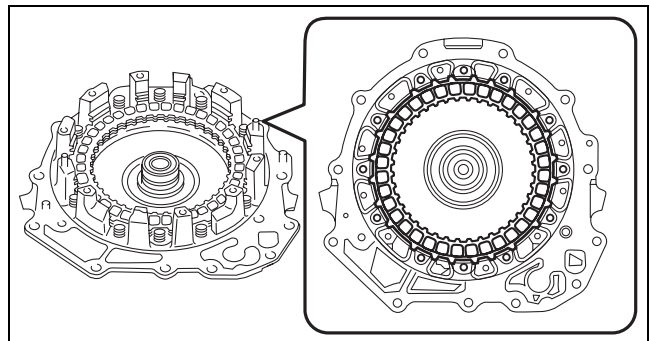

azzjjw00001017

5. Assemble the retaining plate.

Note

- Retaining plate size: Inner diameter approx. 141.8 mm {5.583 in}

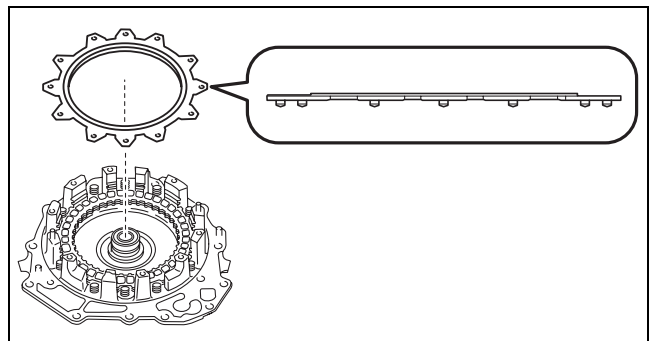

azzjjw00001018

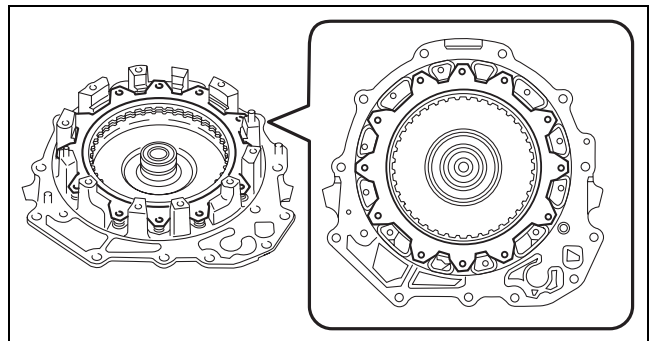

azzjjw00001019

AUTOMATIC TRANSAXLE

6. Assemble the snap ring using the following procedure:

Note

- Snap ring size: Outer diameter approx. 186.2 mm {7.331 in}

(1) Set the snap ring selected in Step 2 on top of the end cover.

A : Selection

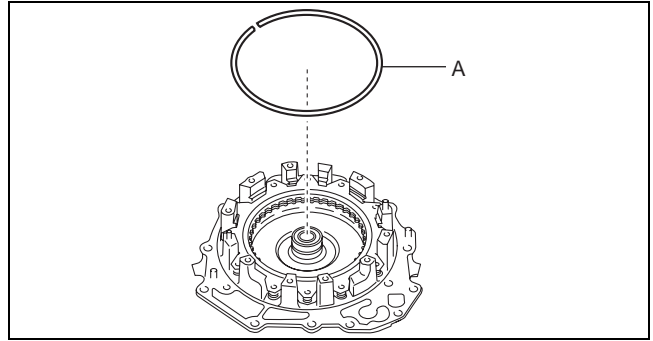

azzjw00001020

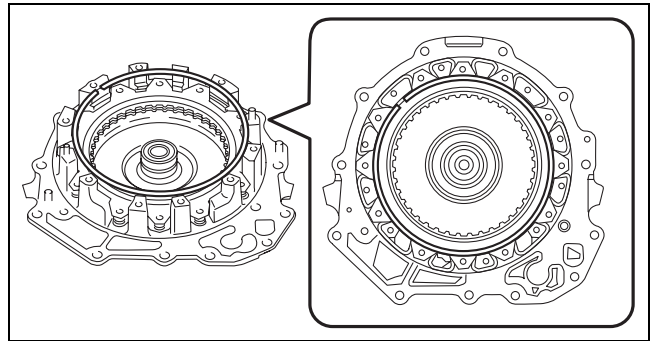

azzjw00001021

(2) Install the SST.

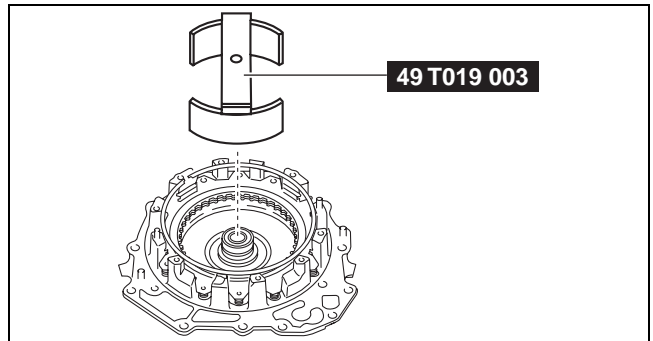

azzjw00001022

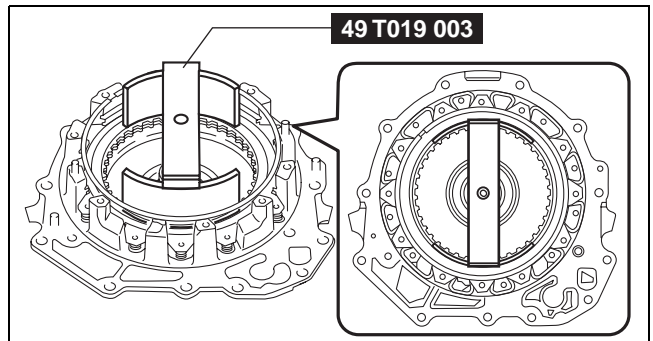

azzjw00001023

AUTOMATIC TRANSAXLE

(3) Set the SST and part to the press as shown in the figure.

- A : Press
B : Rubber plate

Caution

- Using the rubber plates, adjust the alignment surface of the end cover with the transaxle case so that it is level. Otherwise the parts could tip over during the procedure and get damaged.

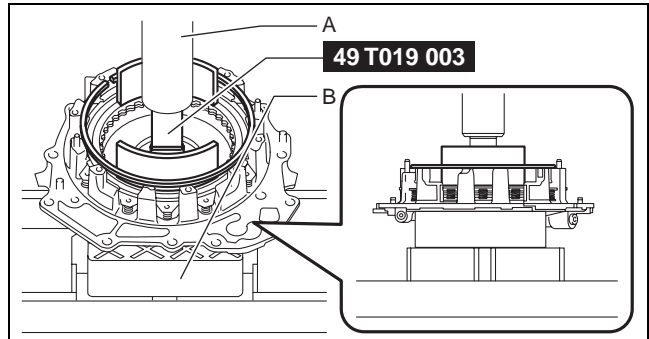

azzjw00001024

(4) Press down the SST using the press until the snap ring groove of the end cover comes out.

- A : Snap ring groove

Caution

- If the SST is pressed excessively by the press, surrounding parts could be damaged. Stop pressing down the SST using the press when the snap ring groove of the end cover comes out.

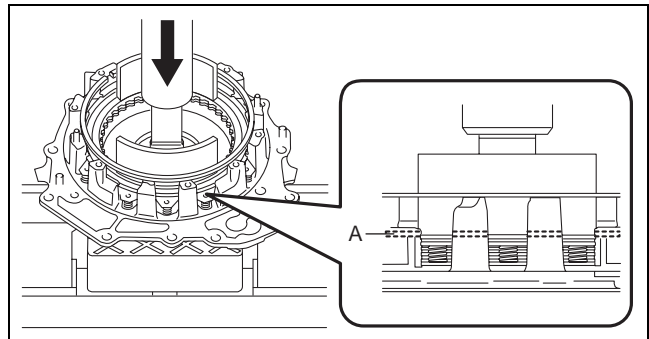

azzjw00001025

(5) Assemble the snap ring to the position shown in the figure.

- A : End gap of snap ring assembly area

Caution

- Assemble the snap ring so that the end gap of the snap ring is in the area shown in the figure.
- After assembling the snap ring, verify that the snap ring is securely inserted into the bottom of the snap ring groove.

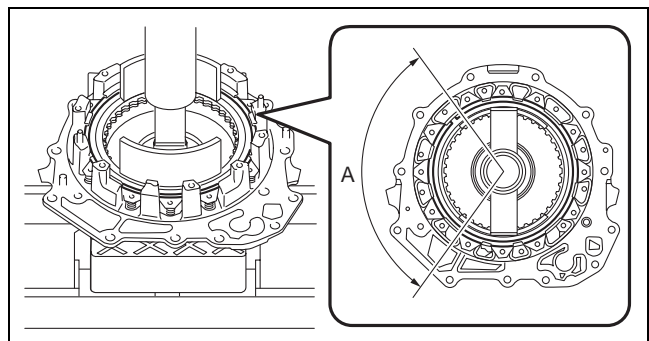

azzjw00001026

(6) Take the SST and part off the press.

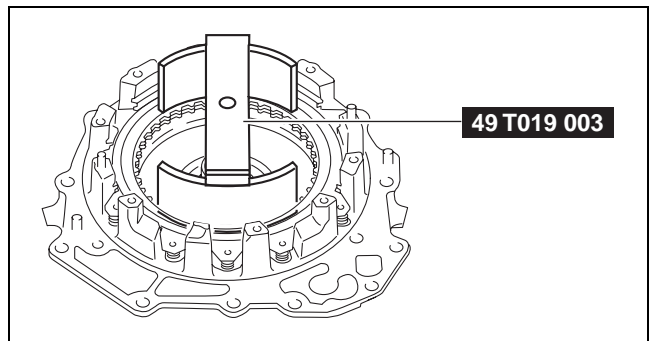

azzjw00001027

AUTOMATIC TRANSAXLE

(7) Remove the SST.

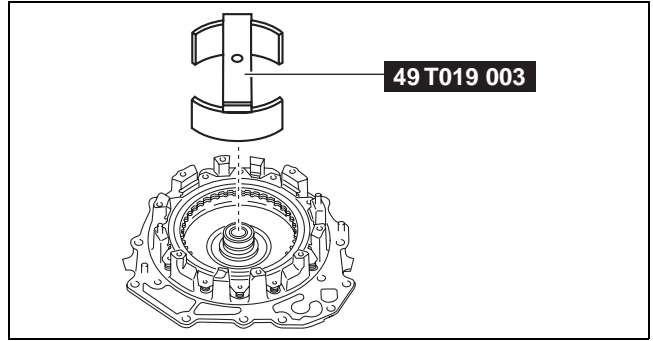

azzjiw00001028

7. Perform an operation verification of the R-3-5 brake using the following procedure:

- (1) Blow compressed air into the oil passage shown in the figure and verify the operation condition of the R-3-5 brake.

Warning

- Always wear protective eye wear when using the air compressor. Otherwise, ATF or dirt particles blown off by the air compressor could get into the eyes.

Caution

- To prevent damage to parts, always use an air compressor which is adjusted to the indicated pressure.

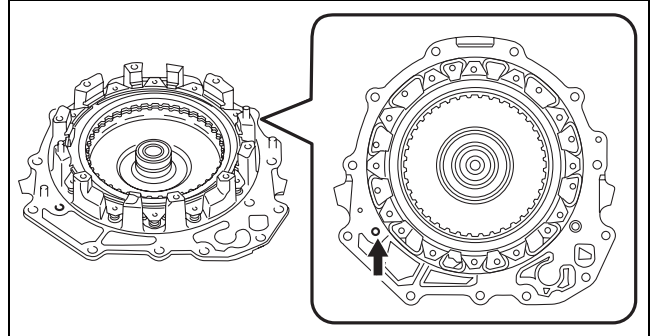

azzjiw00001029

Compressed air pressure

0.39—0.44 MPa {4.0—4.4 kgf/cm², 57—63 psi}

- If there is a malfunction, perform disassembly again, verify the cause and repair the applicable part. (See 05-17-128 END COVER COMPONENT DISASSEMBLY.)

8. Assemble the thrust needle bearing.

Note

- Thrust needle bearing size: Outer diameter approx. 63 mm {2.5 in}

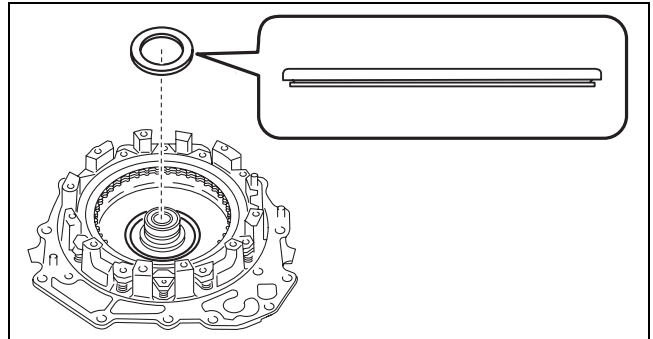

azzjiw00001030

AUTOMATIC TRANSAXLE

9. Assemble the reduction internal gear.

Note

- While rotating the reduction internal gear, engage the splines of each of the R-3-5 brake drive plates one by one, and assemble.

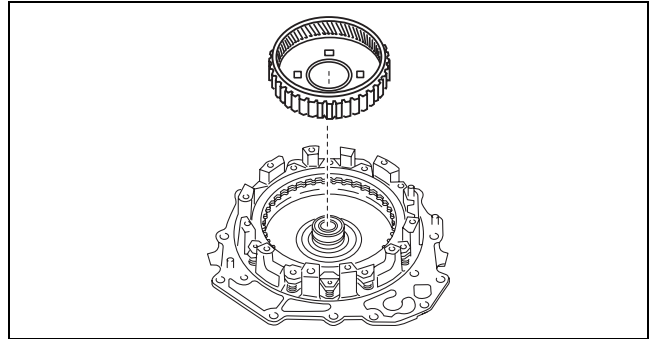

azzjjw00001031

05-17

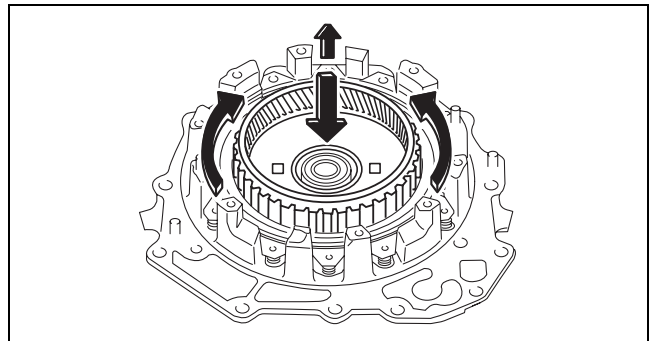

azzjjw00001032

10. To verify that the reduction internal gear is securely assembled, measure the distance shown in the figure.

A : End cover end (alignment surface with brake housing)

B : Reduction internal gear end

Note

- Recommended measuring instrument: Depth gauge, straight edge ruler

Specification

45.0—46.1 mm {1.78—1.81 in}

- If not within the specification, remove the reduction internal gear and reassemble.

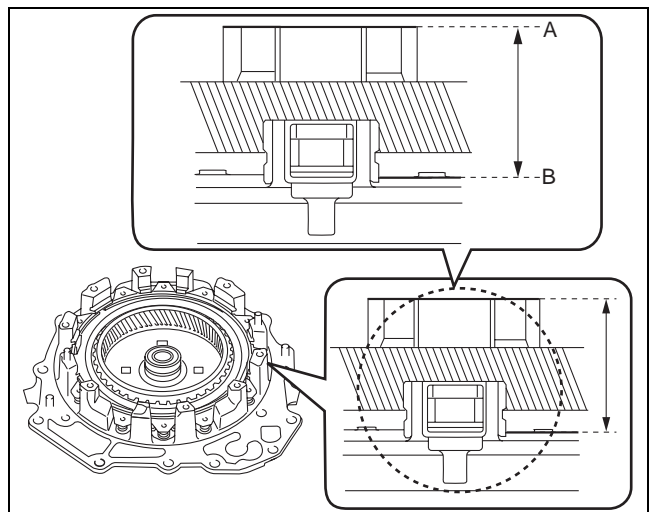

azzjjw00001549

Note

- Measurement method

(1) Set two straight edge rulers along the alignment surfaces of the end cover with the brake housing as shown in the figure.

A : Straight edge ruler

(2) Measure the positions (2 locations) shown in the figure using a depth gauge and calculate the average value.

(3) Subtract the thickness of the straight edge ruler from the average value.

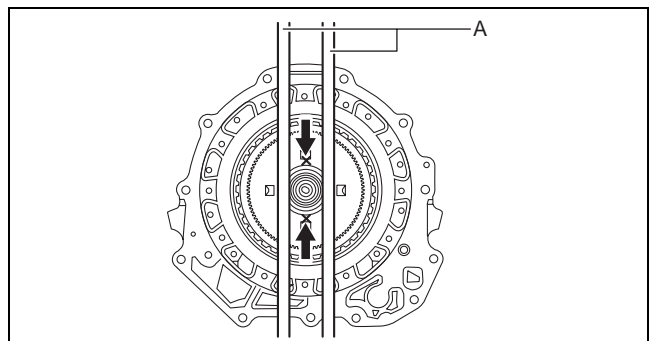

azzjjw00001034

AUTOMATIC TRANSAXLE

11. Assemble the thrust needle bearing.

Note

- Thrust needle bearing size: Outer diameter approx. 63 mm {2.5 in}

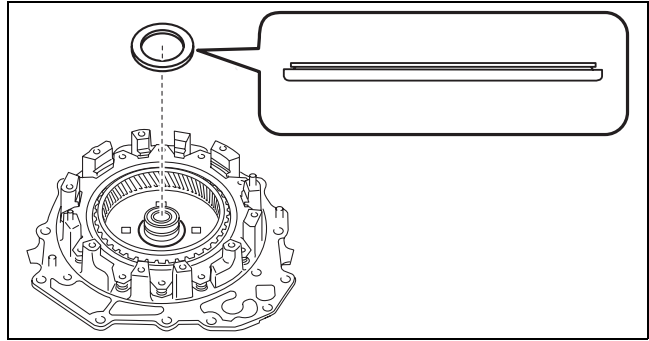

azzjiw00001035

12. Assemble the retaining plate.

Note

- Retaining plate size: Inner diameter approx. 148 mm {5.83 in}

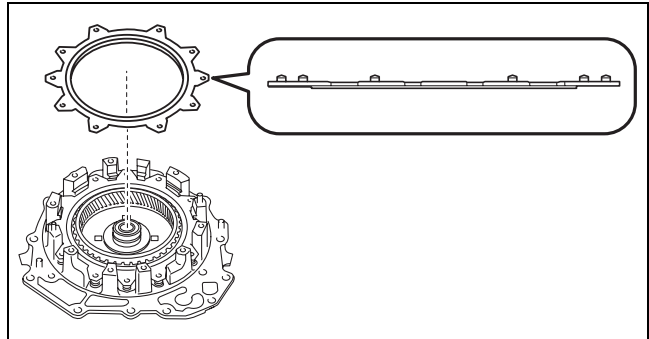

azzjiw00001036

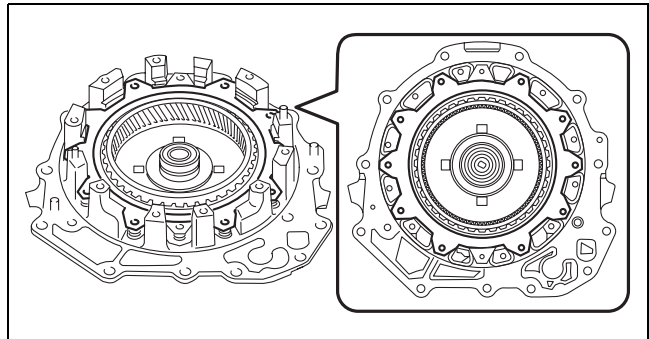

azzjiw00001037

AUTOMATIC TRANSAXLE

13. Assemble the drive plates and driven plates using the following procedure:

Caution

- The driven plate has a similar shape to the retaining plate used for the 2-6 brake clearance adjustment. Before assembling the driven plate, always verify the plate thickness and the shape.

Note

- Drive plate size: Outer diameter approx. 171.9 mm {6.768 in}
- Driven plate size: Inner diameter approx. 148 mm {5.83 in}, thickness approx. 1.6 mm {0.063 in}

05-17

(1) Apply ATF (ATF FZ) to the drive plates and driven plates.

Caution

- If the drive plate is replaced with a new one, immerse it in ATF (ATF FZ) for 2 hours or more to permeate the facing with ATF.

(2) Assemble the drive plates and driven plates.

A : Drive plate

B : Driven plate

Assembly order

Drive plate—driven plate—drive plate—driven plate—drive plate—driven plate—drive plate

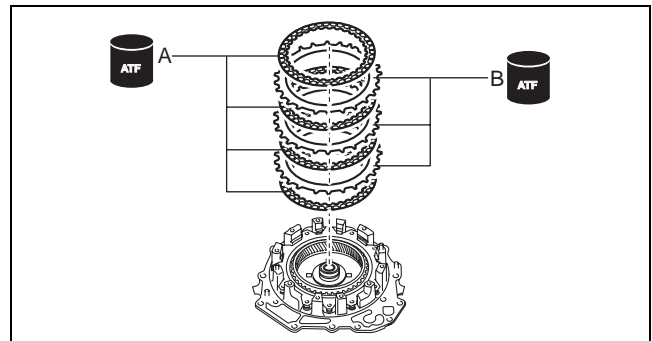

azzjw00001038

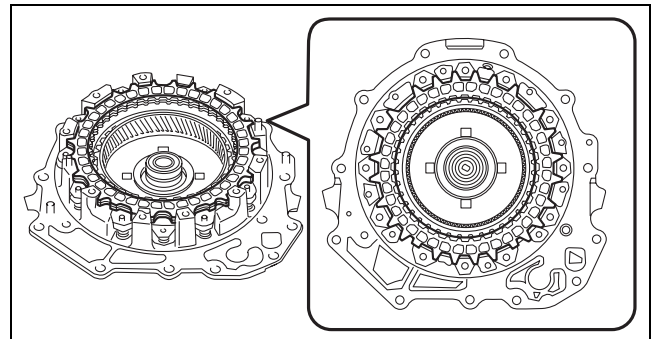

azzjw00001039

AUTOMATIC TRANSAXLE

14. Assemble the reduction planetary gear.

Note

- If the reduction planetary gear assembly is difficult, assembly is easier if the work is performed using the following procedure:

(1) Remove the drive plates and driven plates.

- A : Drive plate
B : Driven plate

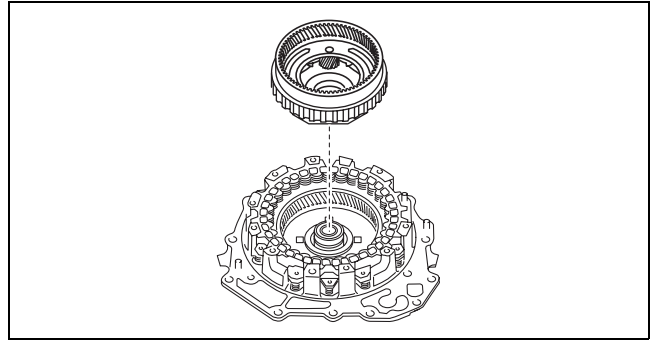

azzjw00001040

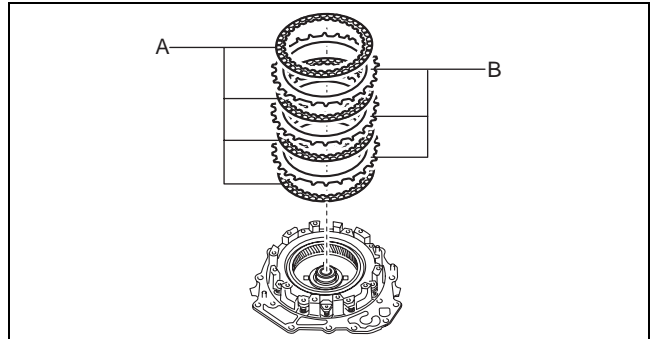

azzjw00001041

(2) Remove the retaining plate.

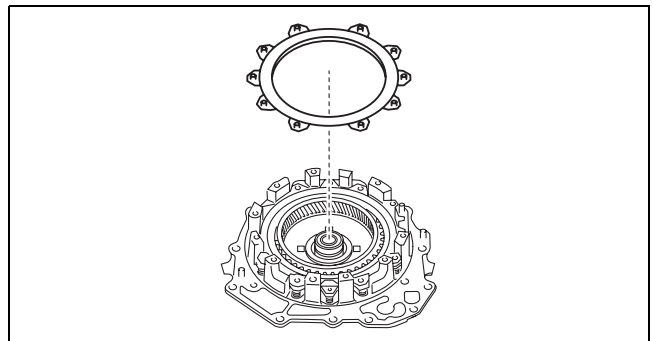

azzjw00001042

AUTOMATIC TRANSAXLE

(3) Assemble the drive plates and driven plates to the reduction planetary gear shown in the figure.

- A : Drive plate
B : Driven plate

Caution

- The driven plate has a similar shape to the retaining plate used for the 2-6 brake clearance adjustment. Before assembling the driven plate, always verify the plate thickness and the shape.

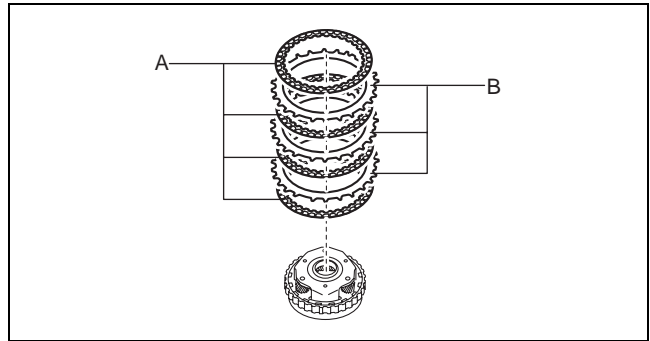

azzjw00001043

Note

- Drive plate size: Outer diameter approx. 171.9 mm {6.768 in}
- Driven plate size: Inner diameter approx. 148 mm {5.83 in}, thickness approx. 1.6 mm {0.063 in}
- Align the spline positions of the driven plate while assembling.

Assembly order

Drive plate—driven plate—drive plate—driven plate—drive plate—driven plate—drive plate

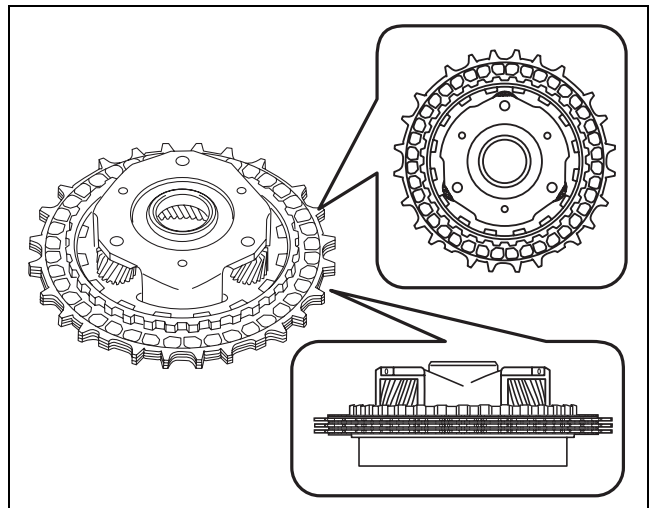

azzjw00001044

(4) Assemble the retaining plate to the reduction planetary gear as shown in the figure.

Note

- Retaining plate size: Inner diameter approx. 148 mm {5.83 in}
- Assemble the retaining plate so that the splines of the retaining plate and the splines of the driven plates are positioned as shown in the figure.

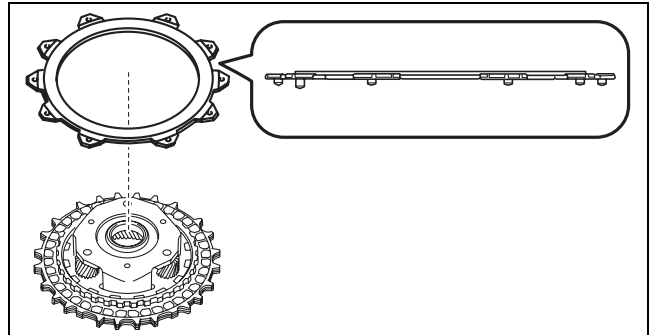

azzjw00001045

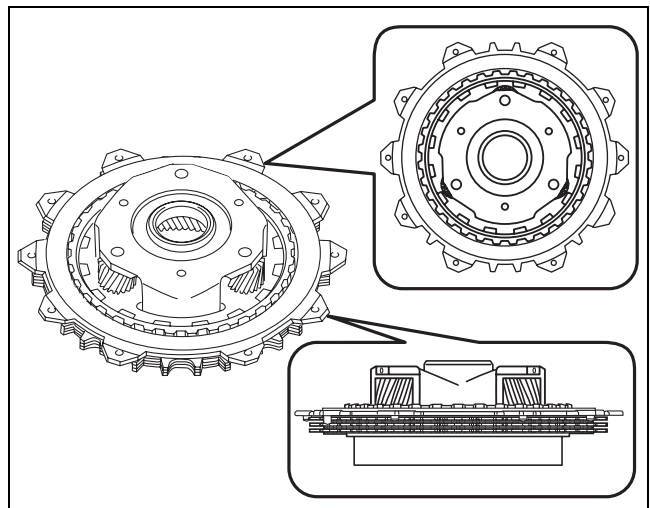

azzjw00001046

AUTOMATIC TRANSAXLE

(5) Assemble the parts assembled together in Steps (3) and (4).

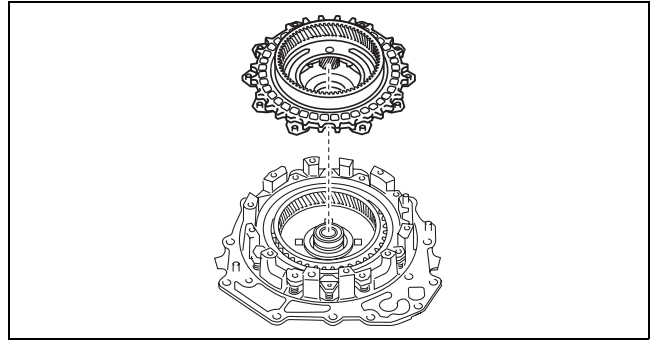

azzjiw00001047

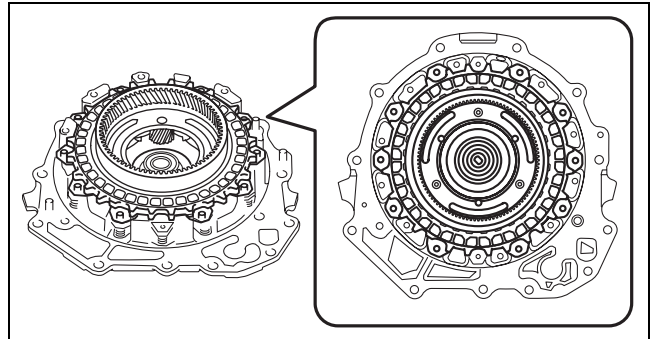

azzjiw00001048

15. To verify that the reduction planetary gear is securely assembled, measure the distance shown in the figure.

A : Reduction planetary gear end (rear internal gear end)

B : End cover end (alignment surface with transaxle case)

Note

- Recommended measuring instrument: Depth gauge, straight edge ruler

Specification

61.3—63.1 mm {2.42—2.48 in}

- If not within the specification, remove the reduction planetary gear and reassemble.

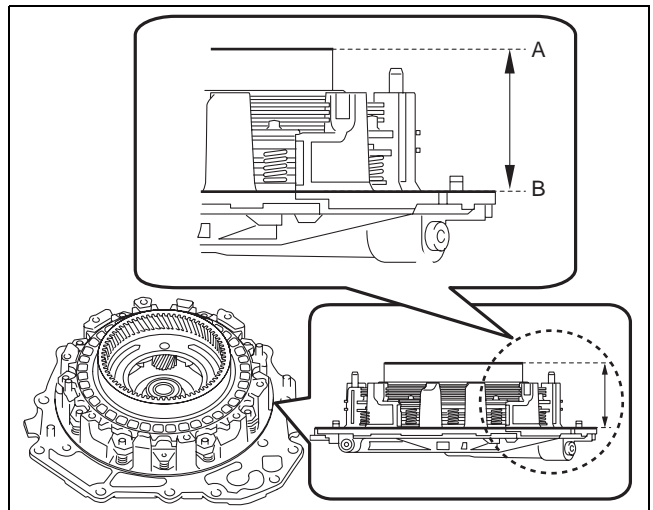

azzjiw00001550

Note

- Measurement method

(1) Set two straight edge rulers on the reduction planetary gear (rear internal gear) as shown in the figure.

A : Straight edge ruler

(2) Measure the positions (2 locations) shown in the figure using a depth gauge and calculate the average value.

(3) Subtract the thickness of the straight edge ruler from the average value.

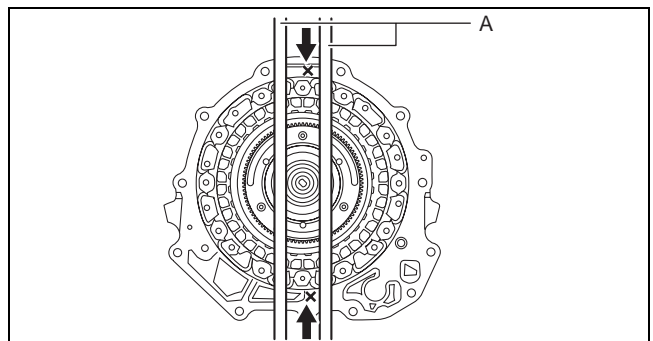

azzjiw00001050

AUTOMATIC TRANSAXLE

16. Assemble the retaining plate using the following procedure:

- (1) Measure the 2-6 brake clearance and select the appropriate retaining plate. (See 05-17-347 2-6 BRAKE CLEARANCE MEASUREMENT/ADJUSTMENT.)

Note

- If the retaining plate is assembled for the 2-6 brake clearance measurement/adjustment, the following retaining plate assembly procedure is not necessary.

- (2) Assemble the retaining plate selected in Step (1).

A : Selection

Note

- Retaining plate: Inner diameter approx. 148 mm {5.83 in}

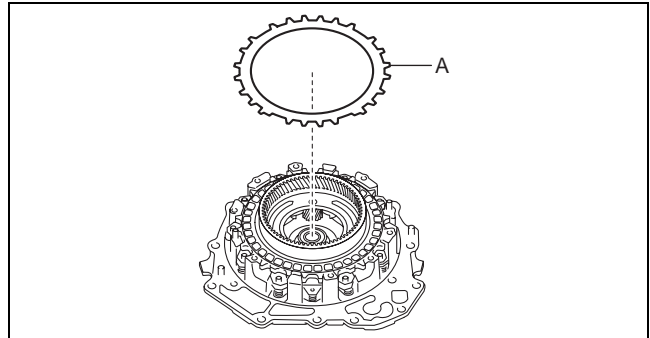

azzjjw00001051

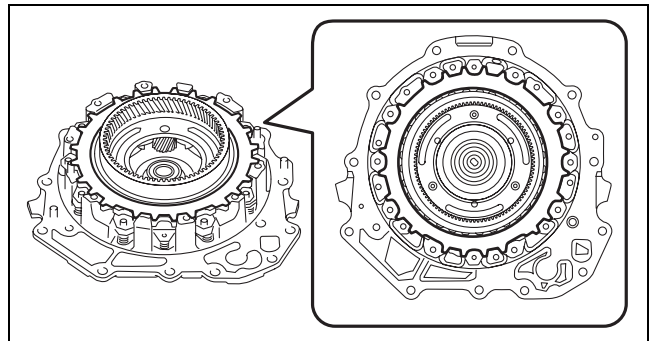

azzjjw00001052

17. Assemble the springs and retainer component.

Note

- Springs and retainer component size: Inner diameter approx. 150.6 mm {5.929 in}

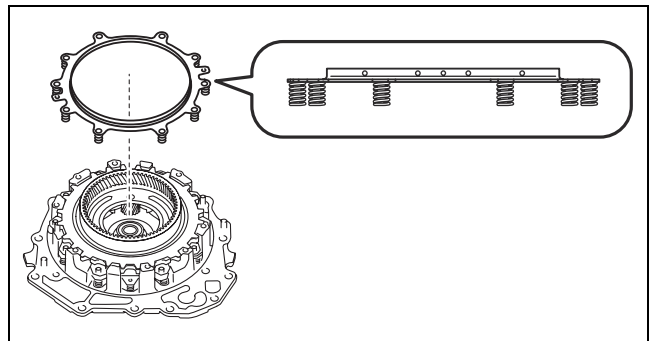

azzjjw00001053

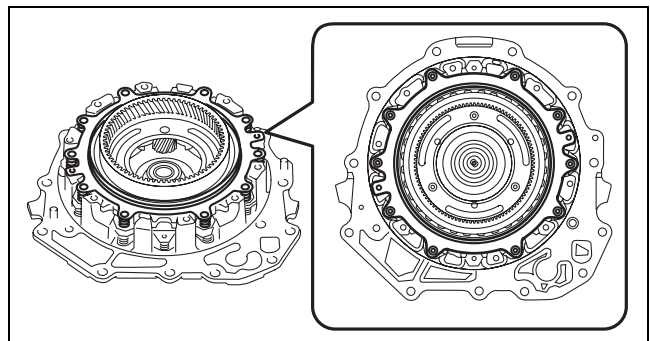

azzjjw00001054

AUTOMATIC TRANSAXLE

18. Assemble the 2-6 brake piston to the brake housing using the following procedure:

- (1) Apply ATF (ATF FZ) to the 2-6 brake piston lip.
- (2) Assemble the 2-6 brake piston.

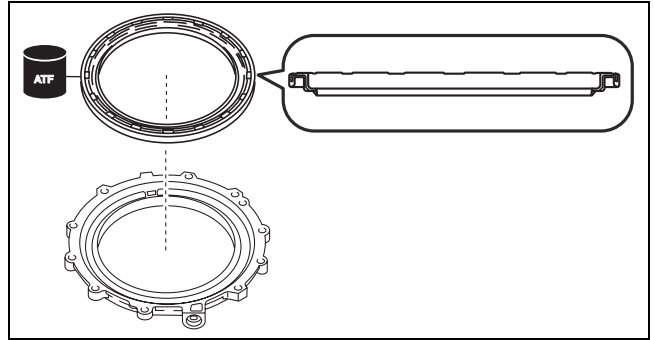

azzjiw00001055

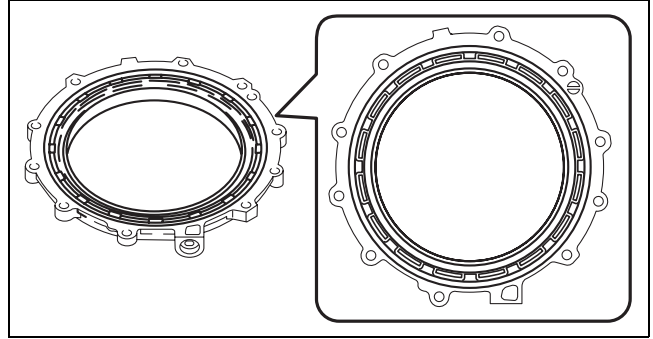

azzjiw00001056

19. Assemble the brake housing using the following procedure:

1	Brake housing
2	8 bolts (M6×1.0 bolt, length to approx. 25 mm {0.98 in})

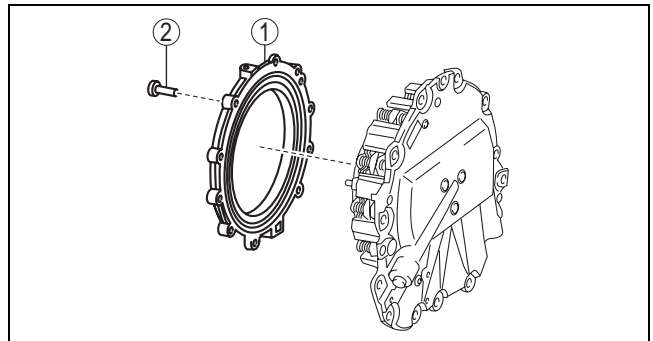

azzjiw00001057

AUTOMATIC TRANSAXLE

(1) Assemble the brake housing.

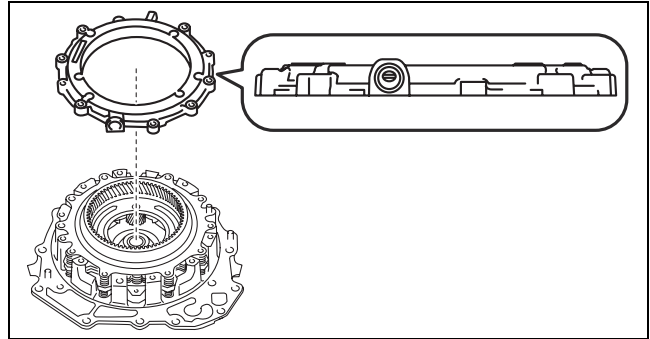

azzjw00001058

05-17

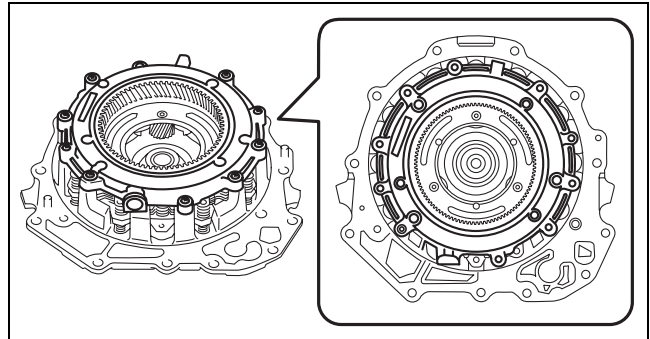

azzjw00001059

(2) Assemble and tighten the bolts shown in the figure uniformly.

Caution

- If the bolts are not tightened uniformly, the brake housing will slant and parts could be damaged due to the spring force of the springs and retainer component in the brake housing.

Note

- Bolt size: M6×1.0 bolt, length to approx. 25 mm {0.98 in}

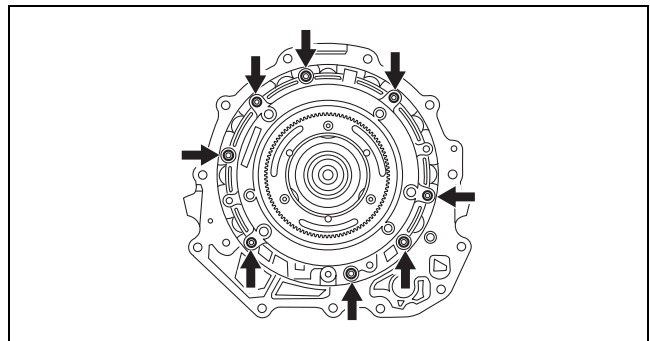

azzjw00001060

Tightening torque

8—10 N·m {82—101 kgf·cm, 71—88 in·lbf}

20. Perform an operation verification of the 2-6 brake using the following procedure:

(1) Blow compressed air into the oil passage shown in the figure and verify the operation condition of the 2-6 brake.

Warning

- Always wear protective eye wear when using the air compressor. Otherwise, ATF or dirt particles blown off by the air compressor could get into the eyes.

Note

- To prevent damage to parts, always use an air compressor which is adjusted to the indicated pressure.

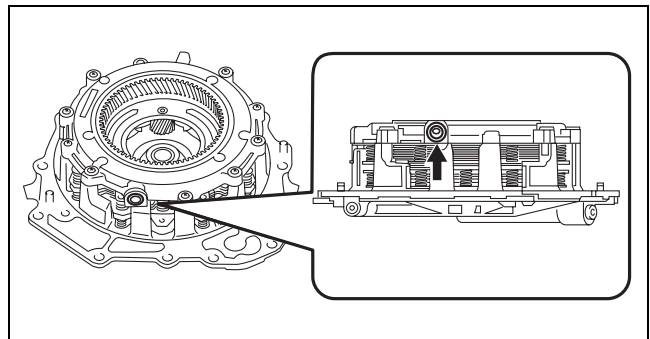

azzjw00001061

Compressed air pressure

0.39—0.44 MPa {4.0—4.4 kgf/cm², 57—63 psi}

- If there is a malfunction, perform disassembly again, verify the cause and repair the applicable part. (See 05-17-128 END COVER COMPONENT DISASSEMBLY.)

AUTOMATIC TRANSAXLE

CONTROL VALVE BODY ASSEMBLY

id051700664300

Structural View

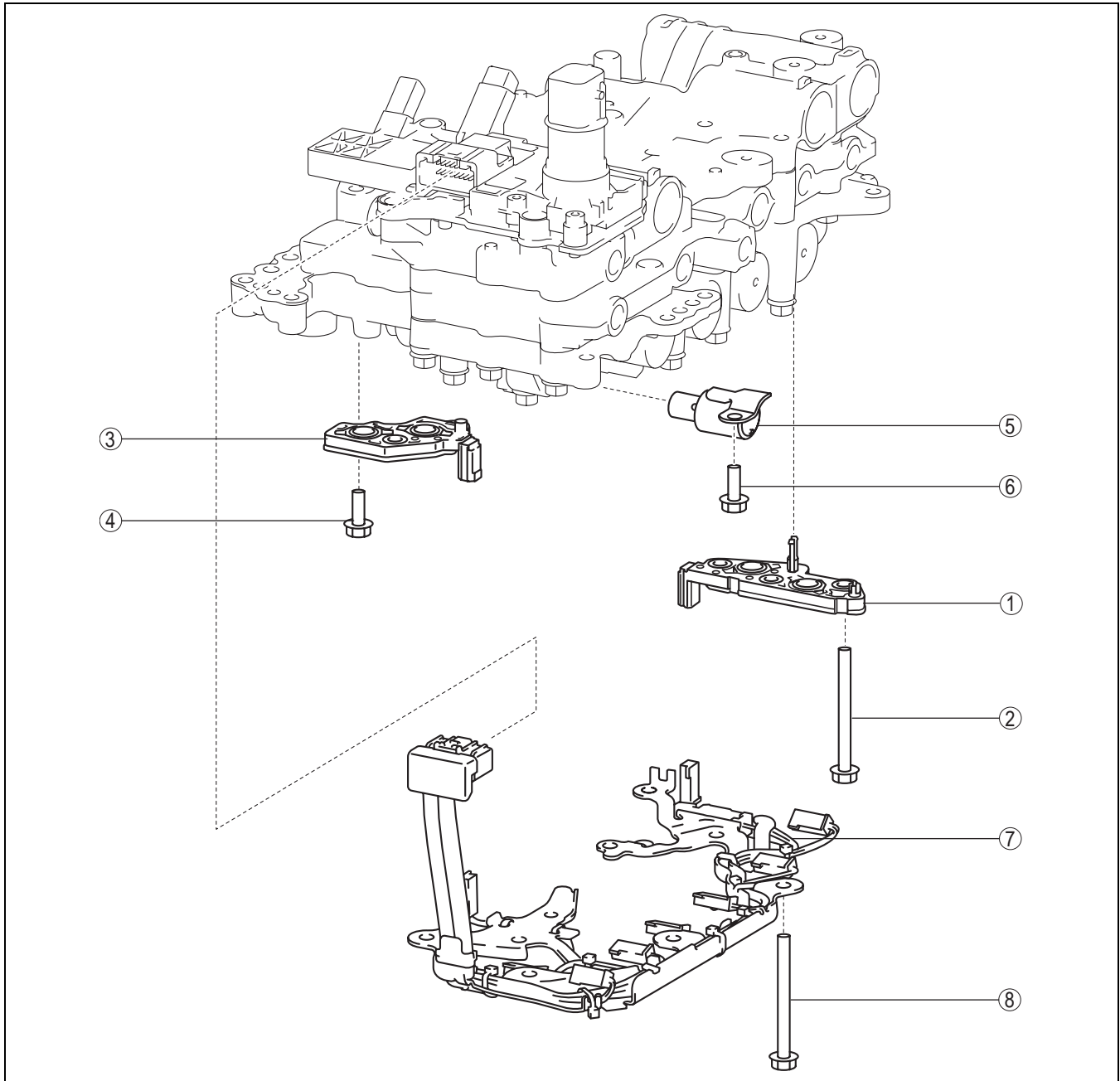

azzjjw00001551

1	Oil pressure switch A
2	3 bolts (M6×1.0 bolt, length to approx. 60 mm {2.4 in})
3	Oil pressure switch B
4	2 bolts (M6×1.0 bolt, length to approx. 60 mm {2.4 in}) 1 bolt (M6×1.0 bolt, length to approx. 16 mm {0.63 in})

5	ON/OFF solenoid
6	Bolt (M6×1.0 bolt, length to approx. 16 mm {0.63 in})
7	Coupler component
8	6 bolts (M6×1.0 bolt, length to approx. 80 mm {3.1 in}) 1 bolt (M6×1.0 bolt, length to approx. 60 mm {2.4 in}) 1 bolt (M6×1.0 bolt, length to approx. 16 mm {0.63 in})

AUTOMATIC TRANSAXLE

Assembly Procedure

Caution

- Do not drop or apply an impact to the control valve body. Replace the control valve body with a new one if it was dropped or received an impact.

- Place the control valve body with the TCM side pointing downward on an impact-absorbing material as shown in the figure.

A : TCM

B : Impact-absorbing material

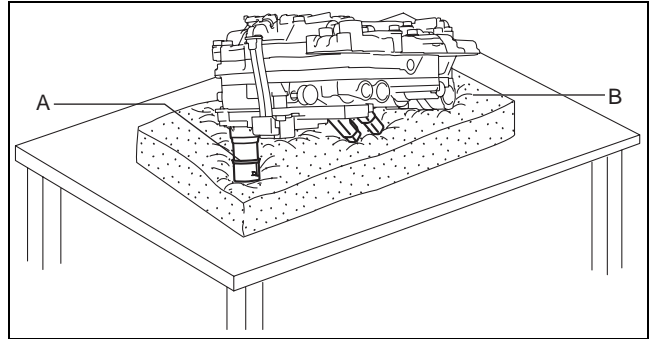

azzjw00001552

05-17

Caution

- Placing the TCM side pointed downward on a workbench directly could damage the TCM. If the TCM side is placed pointed downward, place the control valve body on an impact-absorbing material so that the TCM does not contact the workbench directly.
- If the control valve body is placed on the workbench with the TCM side pointing upward, the pins securing the solenoids shown in the figure could fall off and become lost. If the solenoid installation position shown in the figure is changed, it will cause a malfunction. To prevent the pin securing the solenoid from falling, always place the control valve body on an impact-absorbing material with the TCM side pointing downward until the coupler component is assembled.

A : Shift solenoid No.1

B : Shift solenoid No.4

C : TCC control solenoid

D : Shift solenoid No.3

E : Shift solenoid No.2

F : Pressure control solenoid

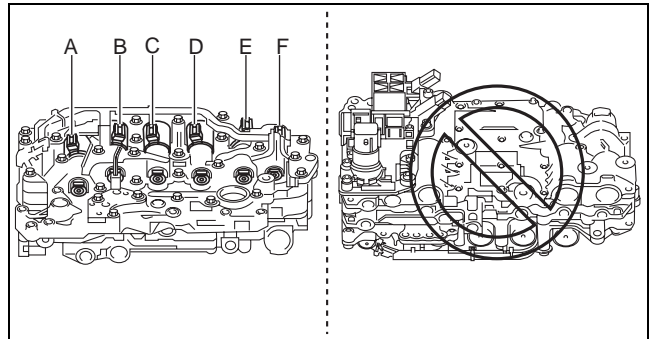

azzjw00001553

- Verify that the pins securing the pressure control solenoid, TCC control valve, and each shift solenoid are not removed using the following procedure:

- (1) Pull each solenoid in the direction of the arrow shown in the figure and verify that it is secured.

A : Shift solenoid No.1

B : Shift solenoid No.4

C : TCC control solenoid

D : Shift solenoid No.3

E : Shift solenoid No.2

F : Pressure control solenoid

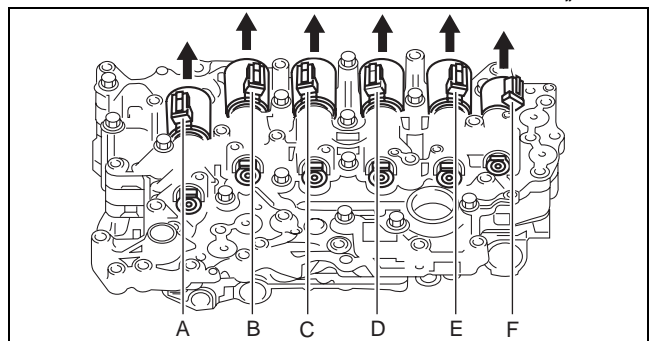

azzjw00000919

- If there is a malfunction, assemble the pin securing the solenoid to the malfunctioning part.

A : Shift solenoid No.1

B : Shift solenoid No.4

C : TCC control solenoid

D : Shift solenoid No.3

E : Shift solenoid No.2

F : Pressure control solenoid

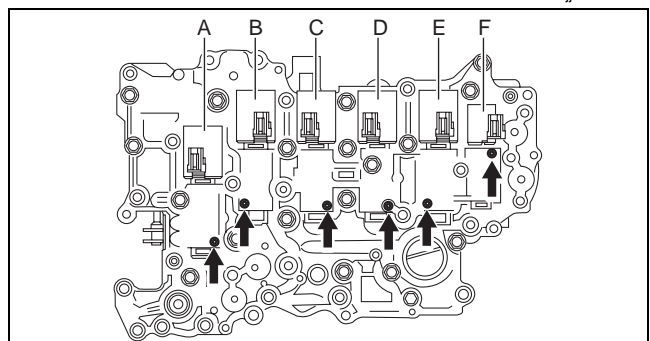

azzjw00000920

AUTOMATIC TRANSAXLE

3. Assemble the oil pressure switch A using the following procedure:

1	Oil pressure switch A
2	3 bolts (M6×1.0 bolt, length to approx. 60 mm {2.4 in})

(1) Assemble the oil pressure switch A.

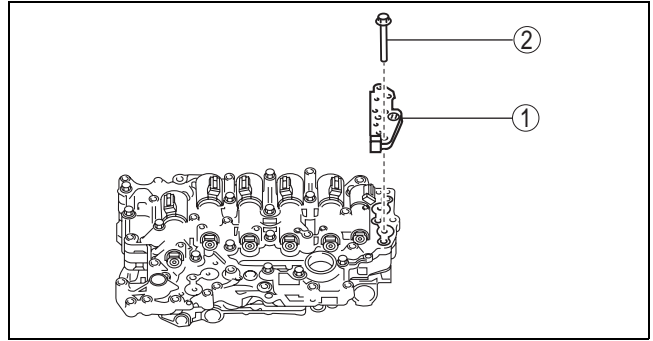

azzjw00000921

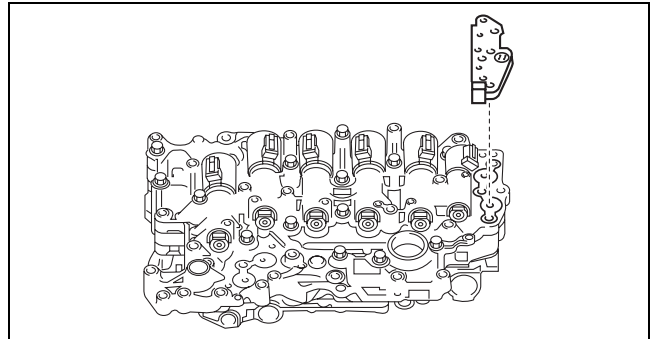

azzjw00000922

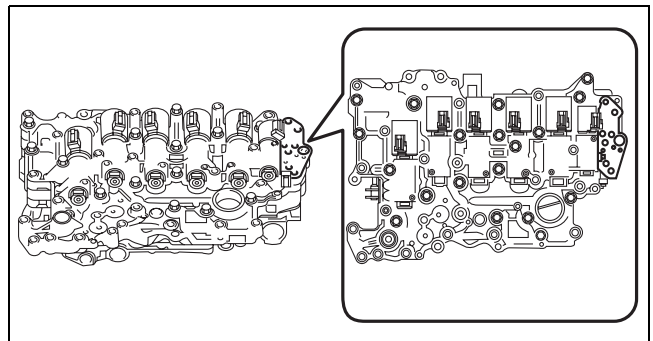

azzjw00000923

(2) Assemble and tighten the bolts shown in the figure.

Note

- Bolt size: M6×1.0 bolt, length to approx. 60 mm {2.4 in}

Tightening torque

9—10 N·m {92—101 kgf·cm, 80—88 in·lbf}

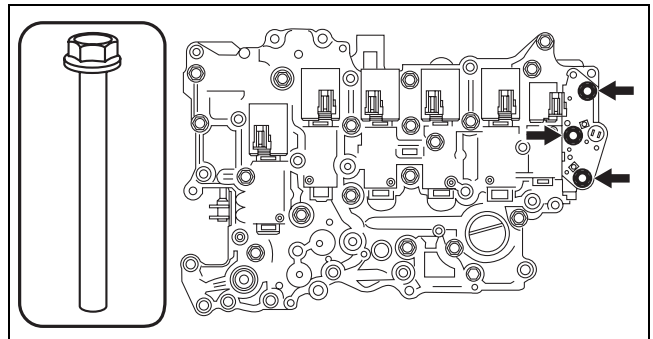

azzjw00000924

AUTOMATIC TRANSAXLE

4. Assemble the oil pressure switch B using the following procedure:

1	Oil pressure switch B
2	2 bolts (M6×1.0 bolt, length to approx. 60 mm {2.4 in}) 1 bolt (M6×1.0 bolt, length to approx. 16 mm {0.63 in})

(1) Assemble the oil pressure switch B.

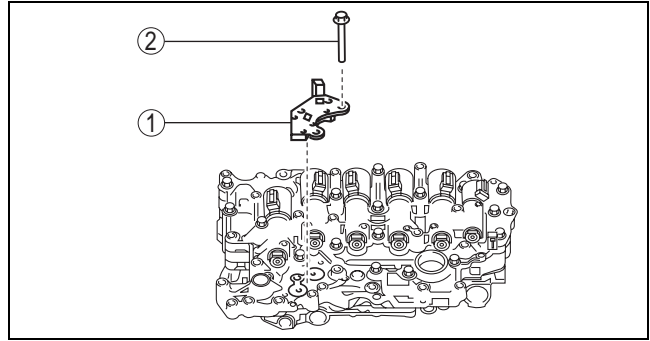

azzjw00000925

05-17

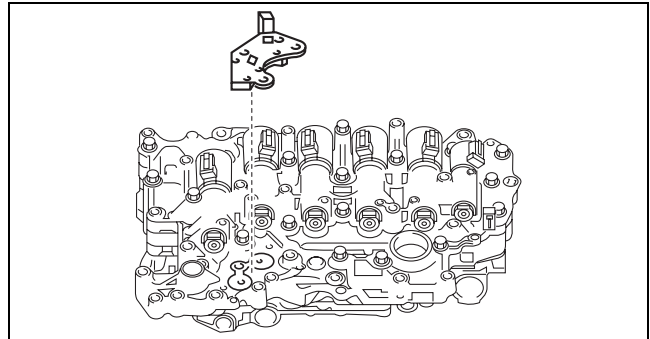

azzjw00000926

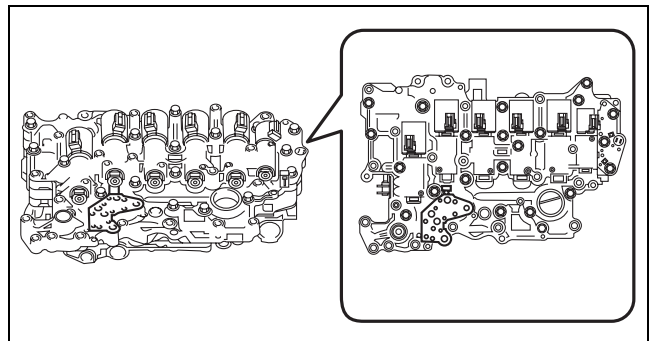

azzjw00000927

(2) Assemble and tighten the bolts shown in the figure.

A : Bolt (M6×1.0 bolt, length to approx. 60 mm {2.4 in})

B : Bolt (M6×1.0 bolt, length to approx. 16 mm {0.63 in})

Tightening torque

9—10 N·m {92—101 kgf·cm, 80—88 in·lbf}

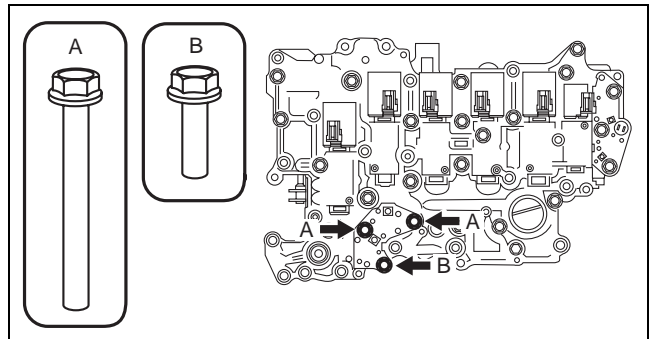

azzjw00000928

AUTOMATIC TRANSAXLE

5. Assemble the ON/OFF solenoid using the following procedure:

1	ON/OFF solenoid
2	Bolt (M6×1.0 bolt, length to approx. 16 mm {0.63 in})

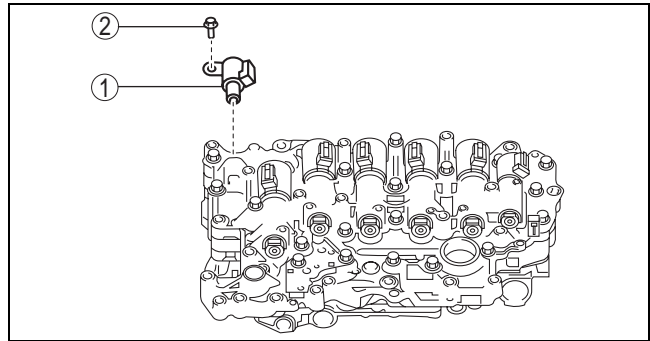

azzjw00000929

(1) Assemble the ON/OFF solenoid.

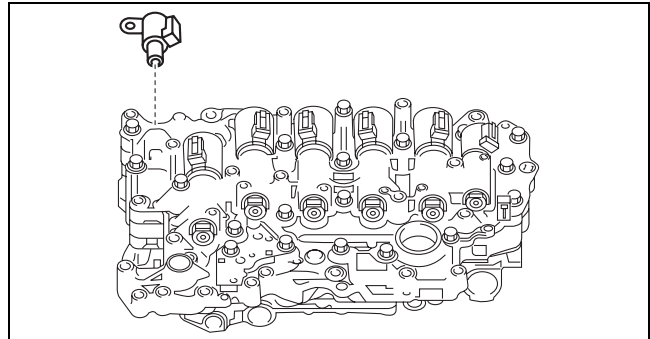

azzjw00000930

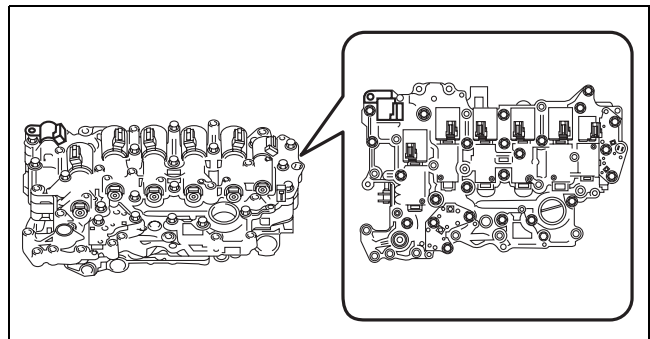

azzjw00000931

(2) Assemble and tighten the bolt shown in the figure.

Note

- Bolt size: M6×1.0 bolt, length to approx. 16 mm {0.63 in}

Tightening torque

9—10 N·m {92—101 kgf·cm, 80—88 in·lbf}

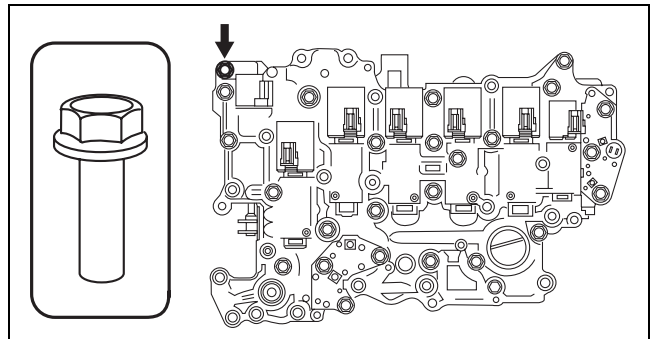

azzjw00000932

AUTOMATIC TRANSAXLE

6. Assemble the coupler component using the following procedure:

1	Coupler component
2	6 bolts (M6×1.0 bolt, length to approx. 80 mm {3.1 in}) 1 bolt (M6×1.0 bolt, length to approx. 60 mm {2.4 in}) 1 bolt (M6×1.0 bolt, length to approx. 16 mm {0.63 in})

(1) Assemble the coupler component.

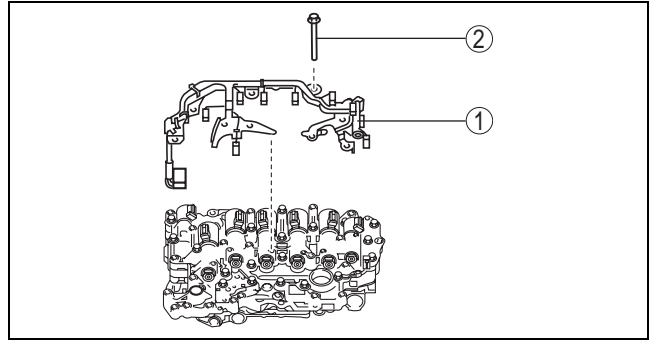

azzjw00000933

05-17

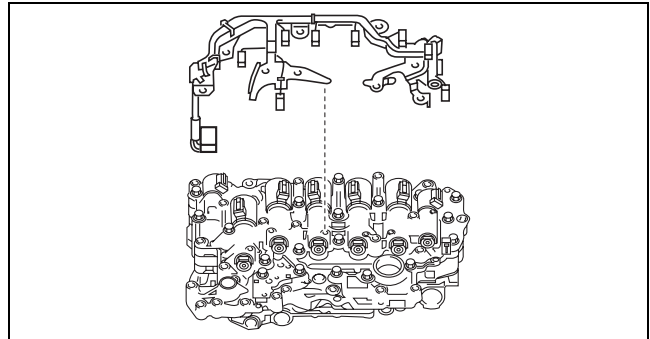

azzjw00000934

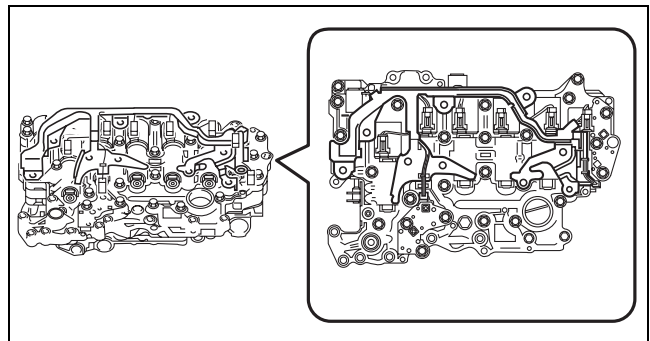

azzjw00000935

(2) Connect the connectors shown in the figure.

Caution

- When connecting a connector, insert it straight until it is securely locked.

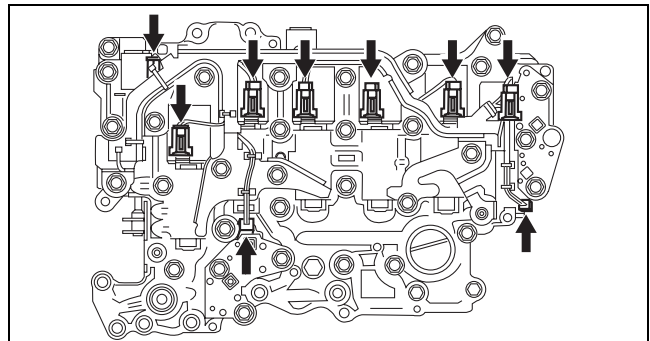

azzjw00000936

AUTOMATIC TRANSAXLE

(3) Assemble and tighten the bolts shown in the figure.

- A : Bolt (M6×1.0 bolt, length to approx. 80 mm {3.1 in})
- B : Bolt (M6×1.0 bolt, length to approx. 60 mm {2.4 in})
- C : Bolt (M6×1.0 bolt, length to approx. 16 mm {0.63 in})

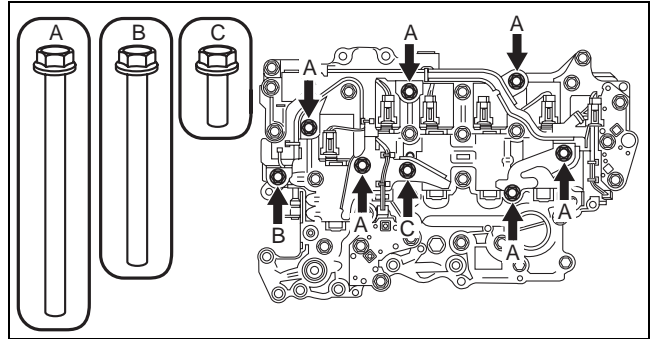

azzjiw00000937

Caution

- Tighten the bolts while pressing the coupler component so that the bolt hole shown in the figure and coupler component hole do not shift.

Tightening torque

9—10 N·m {92—101 kgf·cm, 80—88 in·lbf}

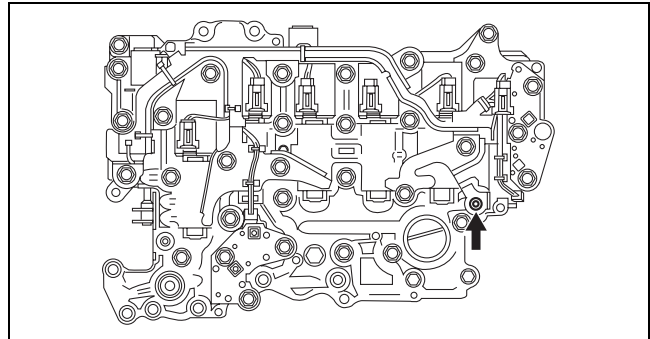

azzjiw00000938

(4) Connect the connector shown in the figure.

Caution

- When connecting a connector, insert it at a straight angle until it is securely locked.

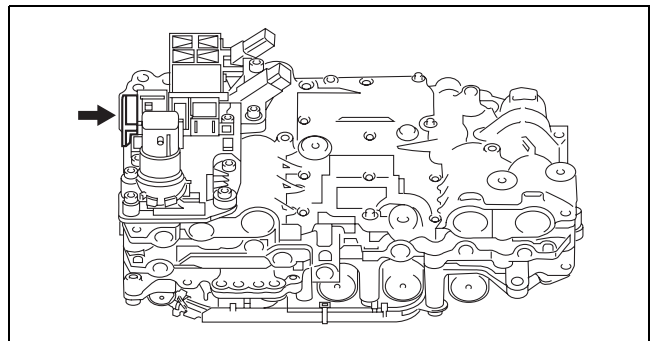

azzjiw00000944

7. Place the assembled control valve body with the TCM side pointing upward on a workbench.

A : TCM

Caution

- Place the assembled control valve body with the TCM side pointing upward on a workbench. If it is placed with the TCM side pointing downward on the workbench, the TCM could be damaged.

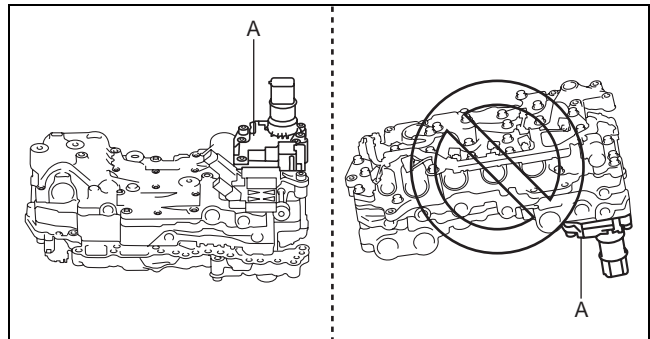

azzjiw00000945

AUTOMATIC TRANSAXLE

MEASUREMENT/ADJUSTMENT VALUE INPUT SHEET

id051700665300

Differential Backlash Measurement/Adjustment

Symbol	Item	Formula	Unit	First time	Second time	Third time
A	FRONT SIDE GEAR AND PINION GEAR BACKLASH	—	mm {in}			
B	REAR SIDE GEAR AND PINION GEAR BACKLASH	—	mm {in}			
C	FRONT DIFFERENTIAL BACKLASH	Average value of A	mm {in}			
D	REAR DIFFERENTIAL BACKLASH	Average value of B	mm {in}			
E	STANDARD DIFFERENTIAL BACKLASH	—	mm {in}	0.030—0.150 {0.0012—0.0059}		
F	MEASUREMENT RESULT OF FRONT DIFFERENTIAL BACKLASH	—	mm {in}	OK/NG	OK/NG	OK/NG
G	MEASUREMENT RESULT OF REAR DIFFERENTIAL BACKLASH	—	mm {in}	OK/NG	OK/NG	OK/NG
H	THICKNESS OF REMOVED FRONT THRUST WASHER	—	mm {in}			
I	THICKNESS OF REMOVED REAR THRUST WASHER	—	mm {in}			
J	MEDIAN VALUE OF DIFFERENTIAL BACKLASH SPECIFICATION	—	mm {in}	0.090 {0.00354}		
K	FRONT DIFFERENTIAL BACKLASH GAP	C - J	mm {in}			
L	REAR DIFFERENTIAL BACKLASH GAP	D - J	mm {in}			
M	FRONT THRUST WASHER THICKNESS GAP	$K \times 0.1 \text{ mm } \{0.00394 \text{ in}\} / 0.08 \text{ mm } \{0.00315 \text{ in}\}$	mm {in}			
N	REAR THRUST WASHER THICKNESS GAP	$L \times 0.1 \text{ mm } \{0.00394 \text{ in}\} / 0.08 \text{ mm } \{0.00315 \text{ in}\}$	mm {in}			
O	THICKNESS OF OPTIMUM FRONT THRUST WASHER	H + M	mm {in}			
P	THICKNESS OF OPTIMUM REAR THRUST WASHER	I + N	mm {in}			

05-17

azzzcw0000074

Description example

Symbol	Item	Formula	Unit	First time	Second time	Third time
A	FRONT SIDE GEAR AND PINION GEAR BACKLASH	—	mm {in}	0.160 {0.00630}	0.170 {0.00669}	0.110 {0.00433}
B	REAR SIDE GEAR AND PINION GEAR BACKLASH	—	mm {in}	0.160 {0.00630}	0.150 {0.00591}	0.085 {0.00335}
C	FRONT DIFFERENTIAL BACKLASH	Average value of A	mm {in}	0.165 {0.00650}	0.105 {0.00413}	
D	REAR DIFFERENTIAL BACKLASH	Average value of B	mm {in}	0.155 {0.00610}	0.080 {0.00315}	
E	STANDARD DIFFERENTIAL BACKLASH	—	mm {in}	0.030—0.150 {0.0012—0.0059}		
F	MEASUREMENT RESULT OF FRONT DIFFERENTIAL BACKLASH	—	mm {in}	OK/NG	OK/NG	OK/NG
G	MEASUREMENT RESULT OF REAR DIFFERENTIAL BACKLASH	—	mm {in}	OK/NG	OK/NG	OK/NG
H	THICKNESS OF REMOVED FRONT THRUST WASHER	—	mm {in}	0.810 {0.03189}		
I	THICKNESS OF REMOVED REAR THRUST WASHER	—	mm {in}	0.795 {0.0313}		
J	MEDIAN VALUE OF DIFFERENTIAL BACKLASH SPECIFICATION	—	mm {in}	0.090 {0.00354}		
K	FRONT DIFFERENTIAL BACKLASH GAP	C - J	mm {in}	0.075 {0.00295}		
L	REAR DIFFERENTIAL BACKLASH GAP	D - J	mm {in}	0.065 {0.00256}		
M	FRONT THRUST WASHER THICKNESS GAP	$K \times 0.1 \text{ mm } \{0.00394 \text{ in}\} / 0.08 \text{ mm } \{0.00315 \text{ in}\}$	mm {in}	0.094 {0.00369}		
N	REAR THRUST WASHER THICKNESS GAP	$L \times 0.1 \text{ mm } \{0.00394 \text{ in}\} / 0.08 \text{ mm } \{0.00315 \text{ in}\}$	mm {in}	0.081 {0.00320}		
O	THICKNESS OF OPTIMUM FRONT THRUST WASHER	H + M	mm {in}	0.904 {0.03559}		
P	THICKNESS OF OPTIMUM REAR THRUST WASHER	I + N	mm {in}	0.876 {0.03449}		

azzzcw0000075

AUTOMATIC TRANSAXLE

High Clutch Clearance Measurement/Adjustment

Symbol	Item	Formula	Unit	First time	Second time	Third time
A	DIAL GAUGE VALUE WITH PISTON OPERATED	—	mm {in}			
B	DIAL GAUGE VALUE WITHOUT PISTON OPERATED	—	mm {in}			
C	HIGH CLUTCH CLEARANCE	A - B	mm {in}			
D	HIGH CLUTCH CLEARANCE SPECIFICATION	—	mm {in}	1.300—1.500 {0.05119—0.05905}		
E	MEASUREMENT RESULT OF HIGH CLUTCH CLEARANCE	—	mm {in}	OK/NG	OK/NG	OK/NG
F	THICKNESS OF REMOVED SNAP RING	—	mm {in}			
G	RANGE	C + F	mm {in}			

azzzcv0000066

Description example

Symbol	Item	Formula	Unit	First time	Second time	Third time
A	DIAL GAUGE VALUE WITH PISTON OPERATED	—	mm {in}	1.605 {0.06319}	1.245 {0.04902}	
B	DIAL GAUGE VALUE WITHOUT PISTON OPERATED	—	mm {in}	0.055 {0.00217}	-0.090 {-0.00354}	
C	HIGH CLUTCH CLEARANCE	A - B	mm {in}	1.550 {0.06102}	1.335 {0.05256}	
D	HIGH CLUTCH CLEARANCE SPECIFICATION	—	mm {in}	1.300—1.500 {0.05119—0.05905}		
E	MEASUREMENT RESULT OF HIGH CLUTCH CLEARANCE	—	mm {in}	OK(NG)	OK(NG)	OK/NG
F	THICKNESS OF REMOVED SNAP RING	—	mm {in}	1.615 {0.06358}		
G	RANGE	C + F	mm {in}	3.165 {0.12461}		

azzzcv0000067

AUTOMATIC TRANSAXLE

Low Clutch Clearance Measurement/Adjustment

Symbol	Item	Formula	Unit	First time	Second time	Third time
A	WEIGHT OF WEIGHT	—	N {kgf, lbf}			
B	CORRECTION VALUE OF LOW CLUTCH CLEARANCE (WEIGHT OF UNIT N)	$(A - 90 \text{ N}) \times 0.00157 \text{ mm } \{0.0000618 \text{ in}\}$	mm {in}			
	CORRECTION VALUE OF LOW CLUTCH CLEARANCE (WEIGHT OF UNIT kgf)	$(A - 9.18 \text{ kgf}) \times 0.01540 \text{ mm } \{0.0006063 \text{ in}\}$	mm {in}			
	CORRECTION VALUE OF LOW CLUTCH CLEARANCE (WEIGHT OF UNIT lbf)	$(A - 20.23 \text{ lbf}) \times 0.00698 \text{ mm } \{0.0002748 \text{ in}\}$	mm {in}			
C	DIAL GAUGE VALUE WITH PISTON OPERATED	—	mm {in}			
D	DIAL GAUGE VALUE WITHOUT PISTON OPERATED	—	mm {in}			
E	LOW CLUTCH CLEARANCE	C - D - B	mm {in}			
F	LOW CLUTCH CLEARANCE SPECIFICATION	—	mm {in}	1.400—1.600 {0.05512—0.06299}		
G	MEASUREMENT RESULT OF LOW CLUTCH CLEARANCE	—	mm {in}	OK/NG	OK/NG	OK/NG
H	THICKNESS OF REMOVED SNAP RING	—	mm {in}			
I	RANGE	E + H	mm {in}			

azzzcv00000064

05-17

Description example

Symbol	Item	Formula	Unit	First time	Second time	Third time
A	WEIGHT OF WEIGHT	—	N {kgf, lbf}	150 {15.30, 33.72}	150 {15.30, 33.72}	
B	CORRECTION VALUE OF LOW CLUTCH CLEARANCE (WEIGHT OF UNIT N)	$(A - 90 \text{ N}) \times 0.00157 \text{ mm } \{0.0000618 \text{ in}\}$	mm {in}	0.0942 {0.00371}	0.0942 {0.00371}	
	CORRECTION VALUE OF LOW CLUTCH CLEARANCE (WEIGHT OF UNIT kgf)	$(A - 9.18 \text{ kgf}) \times 0.01540 \text{ mm } \{0.0006063 \text{ in}\}$	mm {in}	/	/	
	CORRECTION VALUE OF LOW CLUTCH CLEARANCE (WEIGHT OF UNIT lbf)	$(A - 20.23 \text{ lbf}) \times 0.00698 \text{ mm } \{0.0002748 \text{ in}\}$	mm {in}	/	/	
C	DIAL GAUGE VALUE WITH PISTON OPERATED	—	mm {in}	2.320 {0.09134}	2.115 {0.08327}	
D	DIAL GAUGE VALUE WITHOUT PISTON OPERATED	—	mm {in}	0.595 {0.02343}	0.480 {0.01890}	
E	LOW CLUTCH CLEARANCE	C - D - B	mm {in}	1.6308 {0.06420}	1.5408 {0.06066}	
F	LOW CLUTCH CLEARANCE SPECIFICATION	—	mm {in}	1.400—1.600 {0.05512—0.06299}		
G	MEASUREMENT RESULT OF LOW CLUTCH CLEARANCE	—	mm {in}	OK/NG	OK/NG	OK/NG
H	THICKNESS OF REMOVED SNAP RING	—	mm {in}	1.705 {0.06713}		
I	RANGE	E + H	mm {in}	3.3358 {0.13133}		

azzzcv00000065

AUTOMATIC TRANSAXLE

R-3-5 Brake Clearance Measurement/Adjustment

Symbol	Item	Formula	Unit	First time
A	RETAINER THICKNESS OF SPRINGS AND RETAINER COMPONENT	—	mm{in}	
B	DIAL GAUGE VALUE WITH R-3-5 BRAKE PISTON OPERATED	—	mm{in}	
C	DIAL GAUGE VALUE WITHOUT R-3-5 BRAKE PISTON OPERATED	—	mm{in}	
D	R-3-5 BRAKE CLEARANCE ADJUSTMENT VALUE	B - C	mm{in}	
E	THICKNESS OF SNAP RING (FZ01 19 469) FOR R-3-5 BRAKE CLEARANCE MEASUREMENT/ ADJUSTMENT	—	mm{in}	
F	RANGE	D + E - A	mm{in}	

azzzcv00000072

Description example

Symbol	Item	Formula	Unit	First time
A	RETAINER THICKNESS OF SPRINGS AND RETAINER COMPONENT	—	mm{in}	1.225 {0.04823}
B	DIAL GAUGE VALUE WITH R-3-5 BRAKE PISTON OPERATED	—	mm{in}	2.280 {0.08976}
C	DIAL GAUGE VALUE WITHOUT R-3-5 BRAKE PISTON OPERATED	—	mm{in}	0.205 {0.00807}
D	R-3-5 BRAKE CLEARANCE ADJUSTMENT VALUE	B - C	mm{in}	2.075 {0.08169}
E	THICKNESS OF SNAP RING (FZ01 19 469) FOR R-3-5 BRAKE CLEARANCE MEASUREMENT/ ADJUSTMENT	—	mm{in}	2.625 {0.10335}
F	RANGE	D + E - A	mm{in}	3.475 {0.13681}

azzzcv00000073

AUTOMATIC TRANSAXLE

2-6 Brake Clearance Measurement/Adjustment

Symbol	Item	Formula	Unit	First time	Second time	Third time
A	RETAINER THICKNESS OF SPRINGS AND RETAINER COMPONENT	—	mm {in}		←	←
B	DISTANCE A	—	mm {in}			
C	AVERAGE VALUE OF DISTANCE A	Average value of B	mm {in}			
D	2-6 BRAKE CLEARANCE	C - A	mm {in}			
E	2-6 BRAKE CLEARANCE SPECIFICATION	—	mm {in}	1.000—1.200 {0.03938—0.04724}		
F	MEASUREMENT RESULT OF 2-6 BRAKE CLEARANCE	—	mm {in}	OK/NG	OK/NG	OK/NG
G	THICKNESS OF REMOVED RETAINING PLATE	—	mm {in}			
H	RANGE	D + G	mm {in}			

05-17

azzzcv00000070

Description example

Symbol	Item	Formula	Unit	First time	Second time	Third time
A	RETAINER THICKNESS OF SPRINGS AND RETAINER COMPONENT	—	mm {in}	1.425 {0.05610}	←	←
B	DISTANCE A	—	mm {in}	2.675 {0.10532}	2.650 {0.10433}	2.665 {0.10492}
				2.670 {0.10512}	2.580 {0.10157}	2.555 {0.10059}
				2.560 {0.10079}	2.565 {0.10098}	
C	AVERAGE VALUE OF DISTANCE A	Average value of B	mm {in}	2.665 {0.10492}	2.565 {0.10098}	
D	2-6 BRAKE CLEARANCE	C - A	mm {in}	1.240 {0.04882}	1.140 {0.04488}	
E	2-6 BRAKE CLEARANCE SPECIFICATION	—	mm {in}	1.000—1.200 {0.03938—0.04724}		
F	MEASUREMENT RESULT OF 2-6 BRAKE CLEARANCE	—	mm {in}	OK(NG)	OK(NG)	OK/NG
G	THICKNESS OF REMOVED RETAINING PLATE	—	mm {in}	2.015 {0.07933}		
H	RANGE	D + G	mm {in}	3.255 {0.12815}		

azzzcv00000071

AUTOMATIC TRANSAXLE

Low and Reverse Brake Clearance Measurement/Adjustment

Symbol	Item	Formula	Unit	First time				Second time				Third time			
A	DIAL GAUGE VALUE WITH PISTON OPERATED	—	mm {in}												
B	DIAL GAUGE VALUE WITHOUT PISTON OPERATED	—	mm {in}												
C	LOW AND REVERSE BRAKE CLEARANCE	A - B	mm {in}												
D	AVERAGE VALUE OF LOW AND REVERSE BRAKE CLEARANCE	Average value of C	mm {in}												
E	LOW AND REVERSE BRAKE CLEARANCE SPECIFICATION	—	mm {in}	1.650—1.850 {0.06497—0.07283}											
F	MEASUREMENT RESULT OF LOW AND REVERSE BRAKE CLEARANCE	—	mm {in}	OK/NG				OK/NG				OK/NG			
G	THICKNESS OF REMOVED SNAP RING	—	mm {in}												
H	RANGE	D + G	mm {in}												

azzzcw0000068

Description example

Symbol	Item	Formula	Unit	First time				Second time				Third time			
A	DIAL GAUGE VALUE WITH PISTON OPERATED	—	mm {in}	2.470 {0.09724}	2.665 {0.10492}	2.070 {0.08150}	1.840 {0.07244}	1.570 {0.06181}	1.845 {0.07264}	1.695 {0.06673}	1.760 {0.06929}				
B	DIAL GAUGE VALUE WITHOUT PISTON OPERATED	—	mm {in}	0.595 {0.02343}	0.765 {0.03012}	0.205 {0.00807}	-0.035 {-0.00138}	-0.105 {-0.00413}	0.155 {0.00610}	0.010 {0.00039}	0.090 {0.00354}				
C	LOW AND REVERSE BRAKE CLEARANCE	A - B	mm {in}	1.875 {0.07382}	1.900 {0.07480}	1.865 {0.07343}	1.875 {0.07382}	1.675 {0.06594}	1.690 {0.06654}	1.685 {0.06634}	1.670 {0.06575}				
D	AVERAGE VALUE OF LOW AND REVERSE BRAKE CLEARANCE	Average value of C	mm {in}	1.879 {0.07398}				1.680 {0.06614}							
E	LOW AND REVERSE BRAKE CLEARANCE SPECIFICATION	—	mm {in}	1.650—1.850 {0.06497—0.07283}											
F	MEASUREMENT RESULT OF LOW AND REVERSE BRAKE CLEARANCE	—	mm {in}	OK/NG				OK/NG				OK/NG			
G	THICKNESS OF REMOVED SNAP RING	—	mm {in}	2.305 {0.09075}											
H	RANGE	D + G	mm {in}	4.184 {0.16472}											

azzzcw0000069

AUTOMATIC TRANSAXLE

Secondary Gear and Output Gear Preload Measurement/Adjustment

Symbol	Item	Formula	Unit	First time	Second time	Third time
A	ANGULAR CONTACT BALL BEARING PRELOAD	—	N·m {kgf·cm, in·lbf}		←	←
B	TOTAL PRELOAD	—	N·m {kgf·cm, in·lbf}			
C	SECONDARY GEAR AND OUTPUT GEAR PRELOAD	B - A	N·m {kgf·cm, in·lbf}			
D	SECONDARY GEAR AND OUTPUT GEAR PRELOAD SPECIFICATION	—	N·m {kgf·cm, in·lbf}	2.8—3.7 {28.6—37.7, 24.8—32.7}		
E	MEASUREMENT RESULT OF SECONDARY GEAR AND OUTPUT GEAR PRELOAD	—	—	OK/NG	OK/NG	OK/NG
F	THICKNESS OF REMOVED SHIM	—	mm {in}			
G	MEDIAN VALUE OF SECONDARY GEAR AND OUTPUT GEAR PRELOAD SPECIFICATION	—	N·m {kgf·cm, in·lbf}	3.25 {33.1, 28.7}		
H	PRELOAD GAP	G - C	N·m {kgf·cm, in·lbf}			
I	SHIM THICKNESS GAP	$H \times 0.1 \text{ mm } \{0.00394 \text{ in}\} / 1.6 \text{ N·m } \{16.3 \text{ kgf·cm, } 14.1 \text{ in·lbf}\}$	mm {in}			
J	THICKNESS OF OPTIMUM SHIM	F + I	mm {in}			

azzzcw0000076

05-17

Description example

Symbol	Item	Formula	Unit	First time	Second time	Third time
A	ANGULAR CONTACT BALL BEARING PRELOAD	—	N·m {kgf·cm, in·lbf}	1.2 {12.2, 10.6}	←	←
B	TOTAL PRELOAD	—	N·m {kgf·cm, in·lbf}	3.7 {37.7, 32.7}	4.4 {44.8, 38.9}	
C	SECONDARY GEAR AND OUTPUT GEAR PRELOAD	B - A	N·m {kgf·cm, in·lbf}	2.5 {25.5, 22.1}	3.2 {32.6, 28.3}	
D	SECONDARY GEAR AND OUTPUT GEAR PRELOAD SPECIFICATION	—	N·m {kgf·cm, in·lbf}	2.8—3.7 {28.6—37.7, 24.8—32.7}		
E	MEASUREMENT RESULT OF SECONDARY GEAR AND OUTPUT GEAR PRELOAD	—	—	OK/NG	OK/NG	OK/NG
F	THICKNESS OF REMOVED SHIM	—	mm {in}	0.855 {0.03366}		
G	MEDIAN VALUE OF SECONDARY GEAR AND OUTPUT GEAR PRELOAD SPECIFICATION	—	N·m {kgf·cm, in·lbf}	3.25 {33.1, 28.7}		
H	PRELOAD GAP	G - C	N·m {kgf·cm, in·lbf}	0.75 {7.6, 6.6}		
I	SHIM THICKNESS GAP	$H \times 0.1 \text{ mm } \{0.00394 \text{ in}\} / 1.6 \text{ N·m } \{16.3 \text{ kgf·cm, } 14.1 \text{ in·lbf}\}$	mm {in}	0.047 {0.00185}		
J	THICKNESS OF OPTIMUM SHIM	F + I	mm {in}	0.902 {0.03551}		

azzzcw0000077

AUTOMATIC TRANSAXLE

Ring Gear and Differential Preload Measurement/Adjustment

Symbol	Item	Formula	Unit	First time	Second time	Third time
A	RING GEAR AND DIFFERENTIAL PRELOAD	—	N·m {kgf·cm, in·lbf}			
B	RING GEAR AND DIFFERENTIAL PRELOAD SPECIFICATION	—	N·m {kgf·cm, in·lbf}	2.8—4.1 {28.6—41.8, 24.8—36.2}		
C	MEASUREMENT RESULT OF RING GEAR AND DIFFERENTIAL PRELOAD	—	—	OK/NG	OK/NG	OK/NG
D	THICKNESS OF REMOVED SHIM	—	mm {in}			
E	MEDIAN VALUE OF RING GEAR AND DIFFERENTIAL PRELOAD SPECIFICATION	—	N·m {kgf·cm, in·lbf}	3.45 {35.2, 30.5}		
F	PRELOAD GAP	E - A	N·m {kgf·cm, in·lbf}			
G	SHIM THICKNESS GAP	F × 0.1 mm {0.00394 in} / 1.5 N·m {15.3 kgf·cm, 13.3 in·lbf}	mm {in}			
H	THICKNESS OF OPTIMUM SHIM	D + G	mm {in}			

azzzdw00000078

Description example

Symbol	Item	Formula	Unit	First time	Second time	Third time
A	RING GEAR AND DIFFERENTIAL PRELOAD	—	N·m {kgf·cm, in·lbf}	2.5 {25.5, 22.1}	3.4 {34.7, 30.1}	
B	RING GEAR AND DIFFERENTIAL PRELOAD SPECIFICATION	—	N·m {kgf·cm, in·lbf}	2.8—4.1 {28.6—41.8, 24.8—36.2}		
C	MEASUREMENT RESULT OF RING GEAR AND DIFFERENTIAL PRELOAD	—	—	OK/NG	OK/NG	OK/NG
D	THICKNESS OF REMOVED SHIM	—	mm {in}	0.905 {0.03563}		
E	MEDIAN VALUE OF RING GEAR AND DIFFERENTIAL PRELOAD SPECIFICATION	—	N·m {kgf·cm, in·lbf}	3.45 {35.2, 30.5}		
F	PRELOAD GAP	E - A	N·m {kgf·cm, in·lbf}	0.95 {9.7, 8.4}		
G	SHIM THICKNESS GAP	F × 0.1 mm {0.00394 in} / 1.5 N·m {15.3 kgf·cm, 13.3 in·lbf}	mm {in}	0.063 {0.00248}		
H	THICKNESS OF OPTIMUM SHIM	D + G	mm {in}	0.968 {0.03811}		

azzzdw00000079

Total End Play Measurement/Adjustment

Symbol	Item	Formula	Unit	First time
A	TOTAL END PLAY ADJUSTMENT VALUE	—	mm{in}	
B	AVERAGE OF TOTAL END PLAY ADJUSTMENT VALUE	Average value of A	mm{in}	
C	THICKNESS OF SHIM (FZ01 19 2L1) FOR TOTAL END PLAY MEASUREMENT/ ADJUSTMENT	—	mm{in}	
D	RANGE	B + C	mm{in}	

azzzdw00000080

Description example

Symbol	Item	Formula	Unit	First time
A	TOTAL END PLAY ADJUSTMENT VALUE	—	mm{in}	0.120 {0.00472} 0.110 {0.00433} 0.110 {0.00433} 0.120 {0.00472}
B	AVERAGE OF TOTAL END PLAY ADJUSTMENT VALUE	Average value of A	mm{in}	0.115 {0.00453}
C	THICKNESS OF SHIM (FZ01 19 2L1) FOR TOTAL END PLAY MEASUREMENT/ ADJUSTMENT	—	mm{in}	3.010 {0.11850}
D	RANGE	B + C	mm{in}	3.125 {0.12303}

azzzdw00000081

DIFFERENTIAL BACKLASH MEASUREMENT/ADJUSTMENT

id051700665400

Preparation Before Servicing

1. Print out the measurement/adjustment value input sheet. (See 05-17-295 MEASUREMENT/ADJUSTMENT VALUE INPUT SHEET.)

Note

- When performing the measurement/adjustment, input the measured and calculated values into the measurement/adjustment value input sheet.
- When performing the other measurements/adjustments, if the measurement/adjustment value input sheet has been printed out, use the printed sheet.

05-17

Differential Backlash Measurement

Note

- Measure the tooth play (gap) between the side gear and pinion gear as the differential backlash.

1. Secure the ring gear and differential in a vise.

A : Vise

Caution

- Insert a protective plate between the vise and the part so as not to damage the part.

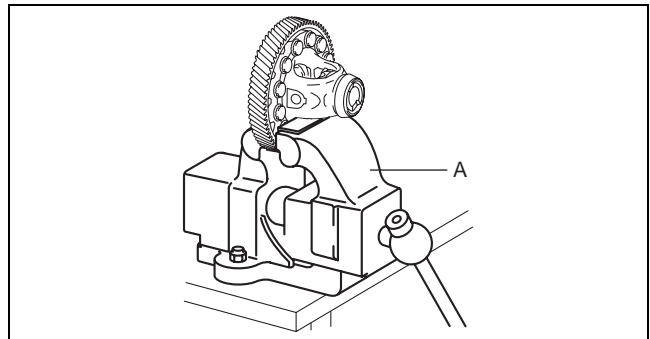

azzjjw00001303

2. Assemble the drive shaft (LH) and joint shaft to the ring gear and differential.

A : Drive shaft (LH)

B : Joint shaft

Caution

- Because the drive shaft (LH) clip is not required for the differential backlash measurement, do not assemble it.

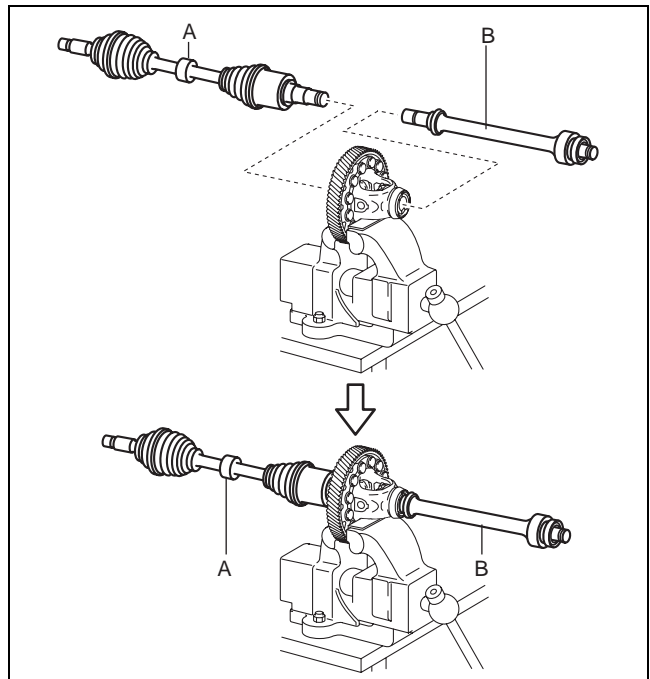

azzjjw00001304

AUTOMATIC TRANSAXLE

3. Set the dial gauge and magnetic stand as shown in the figure.

- A : Dial gauge
B : Magnetic stand

Caution

- To reduce error during the backlash measurement, set the dial gauge so that it is perpendicular to the teeth of the pinion gear.

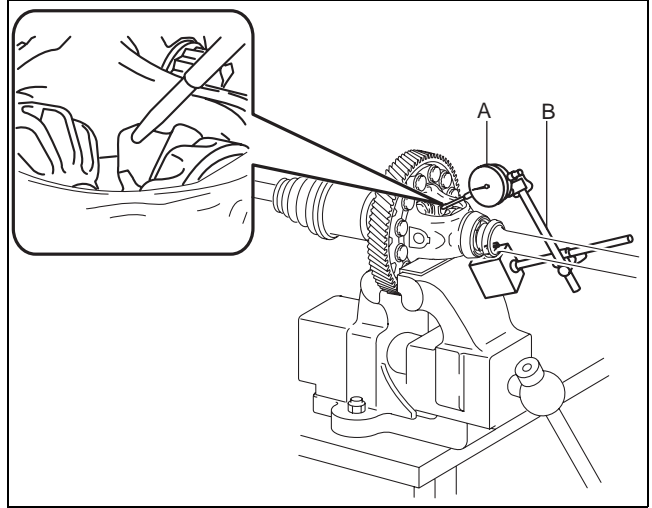

azzjiw00001349

4. Set the dial gauge end to the pinion gear teeth.

- A : Area in which dial gauge end is set

Caution

- To reduce error during the backlash measurement, set the dial gauge end to within the area shown in the figure.

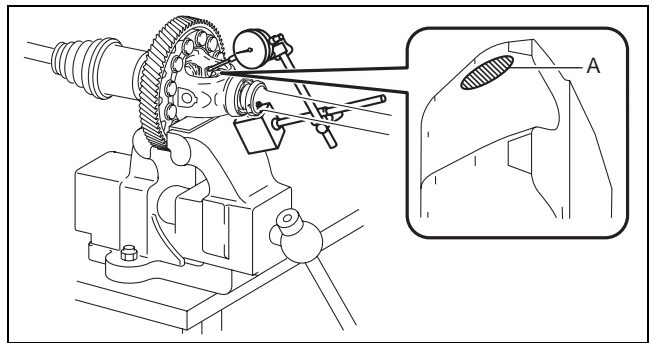

azzjiw00001306

5. Secure the side gear on the front side by hand.

- A : Secure by hand

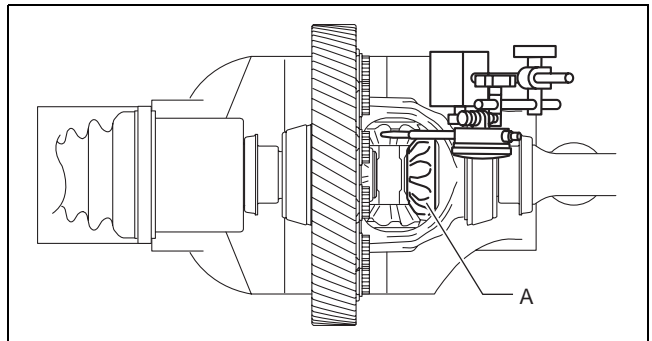

azzjiw00001307

6. Move the pinion gear with the dial gauge that has been set by hand and measure the backlash.

- A : Secure by hand
B : Move the pinion gear by hand such that the secured side gear does not move.

Caution

- Because a difference occurs in the backlash measurement value if the secured side gear moves, move the pinion gear by hand so that the secured side gear does not move.

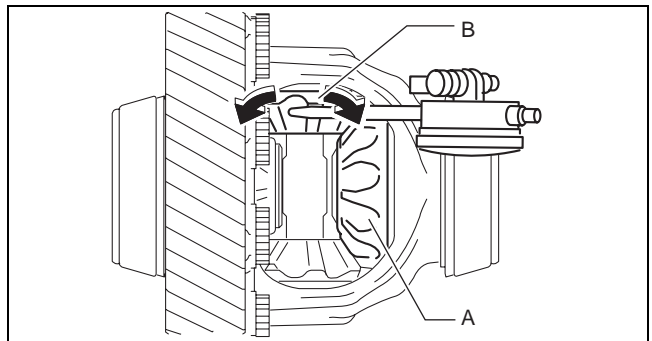

azzjiw00001426

AUTOMATIC TRANSAXLE

7. Input the measured side gear on the front side and pinion gear backlash into the measurement/adjustment value input sheet.

Note

- Input into section A in the measurement/adjustment value input sheet.

8. Secure the side gear on the rear side by hand.

A : Secure by hand

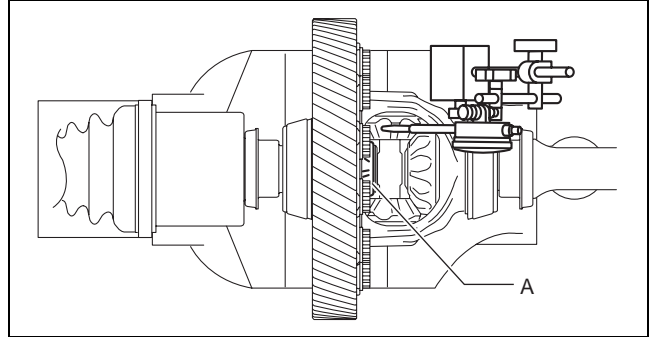

azzjw00001379

05-17

9. Move the pinion gear with the dial gauge that has been set by hand and measure the backlash.

A : Secure by hand

B : Move the pinion gear by hand such that the secured side gear does not move.

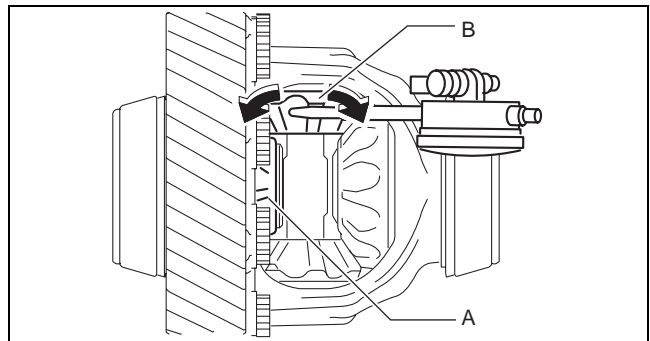

azzjw00001427

10. Input the measured side gear on the rear side and the pinion gear backlash into the measurement/adjustment value sheet.

Note

- Input into section B in the measurement/adjustment value sheet.

11. Set the dial gauge and magnetic stand to the pinion gear on the opposite side.

A : Dial gauge

B : Magnetic stand

Caution

- To reduce error during the backlash measurement, set the dial gauge so that it is perpendicular to the teeth of the pinion gear.

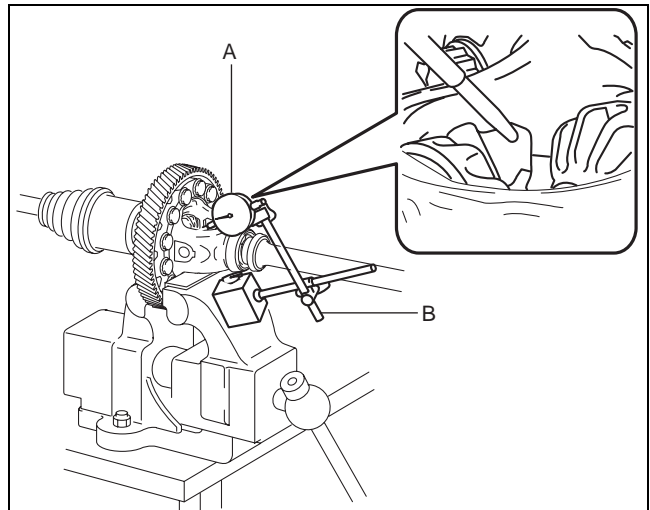

azzjw00001381

AUTOMATIC TRANSAXLE

12. Set the dial gauge end to the pinion gear teeth.

A : Area in which dial gauge end is set

Caution

- To reduce error during the backlash measurement, set the dial gauge end to within the area shown in the figure.

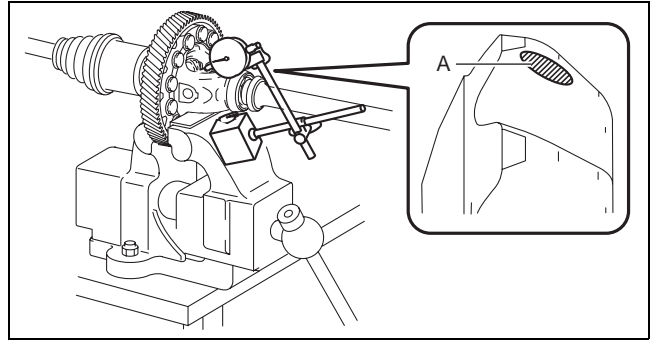

azzijw00001382

13. Secure the side gear on the front side by hand.

A : Secure by hand

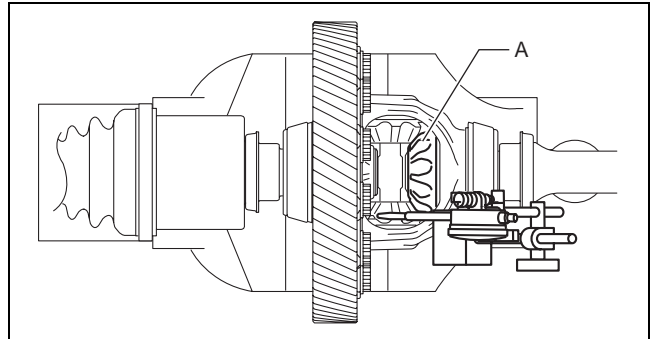

azzijw00001383

14. Move the pinion gear with the dial gauge that has been set by hand and measure the backlash.

A : Secure by hand

B : Move the pinion gear by hand such that the secured side gear does not move.

Caution

- Because a difference occurs in the backlash measurement value if the secured side gear moves, move the pinion gear by hand so that the secured side gear does not move.

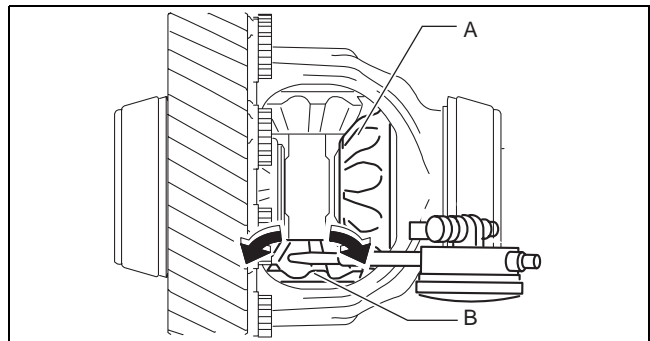

azzijw00001428

15. Input the measure side gear on the front side and the pinion gear backlash into the measurement/adjustment value sheet.

Note

- Input into section A in the measurement/adjustment value sheet.

AUTOMATIC TRANSAXLE

16. Secure the side gear on the rear side by hand.

A : Secure by hand

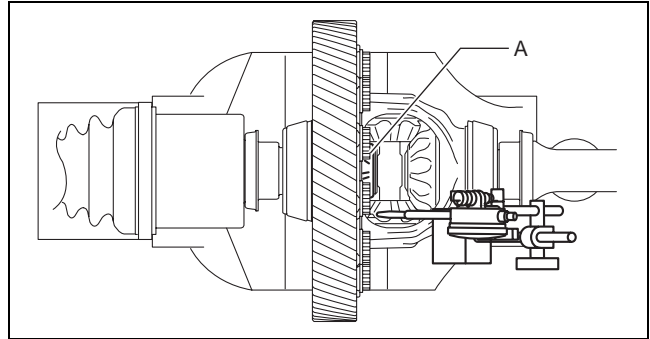

azzjjw00001385

17. Move the pinion gear with the dial gauge that has been set by hand and measure the backlash.

A : Secure by hand

B : Move the pinion gear by hand such that the secured side gear does not move.

Caution

- Because a difference occurs in the backlash measurement value if the secured side gear moves, move the pinion gear by hand so that the secured side gear does not move.

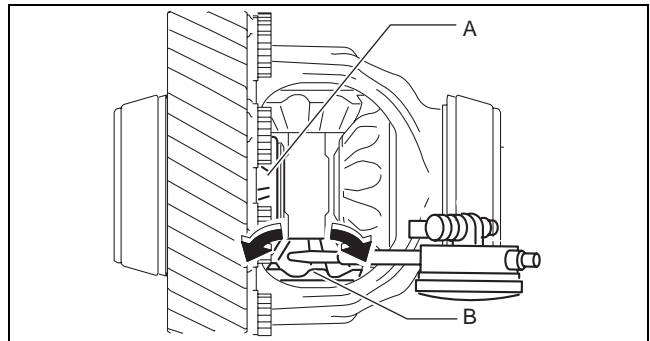

azzjjw00001429

18. Input the measured side gear on the rear side and the pinion gear backlash into the measurement/adjustment value sheet.

Note

- Input into section B in the measurement/adjustment value sheet.

19. Calculate the average value of the measured side gear on the front side and the pinion gear backlash.

20. Input the average value of the calculated side gear on the front side and the pinion gear backlash into the measurement/adjustment value sheet.

Note

- The average value of the calculated side gear on the front side and the pinion gear backlash is the differential backlash on the front side.

21. Calculate the average value of the measured side gear on the rear side and the pinion gear backlash.

22. Input the average value of the calculated side gear on the rear side and the pinion gear backlash into the measurement/adjustment value sheet.

Note

- The average value of the calculated side gear on the rear side and the pinion gear backlash is the differential backlash on the rear side.

23. Verify that the differential backlash on the front side and the differential backlash on the rear side satisfy the specification.

Specification

0.030—0.150 mm {0.0012—0.0059 in}

- If not within the specification, perform the differential backlash adjustment. (See 05-17-309 Differential Backlash Adjustment.)
- If it exceeds the specification even if the thrust washer with a thickness of 0.95 mm {0.037 in}, which is the thickest, is assembled after performing the differential backlash adjustment, disassemble the ring gear and differential and replace the differential gear case with a new one. (See 05-17-121 RING GEAR AND DIFFERENTIAL DISASSEMBLY.) (See 05-17-266 RING GEAR AND DIFFERENTIAL ASSEMBLY.)

AUTOMATIC TRANSAXLE

24. Remove the dial gauge and magnetic stand.

- A : Dial gauge
- B : Magnetic stand

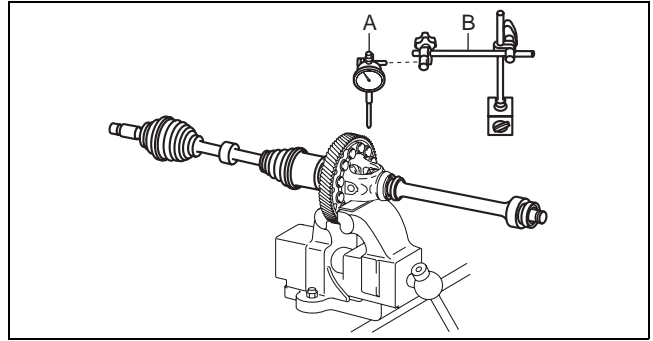

azzjw00001309

25. Remove the drive shaft (LH) and joint shaft.

- A : Drive shaft (LH)
- B : Joint shaft

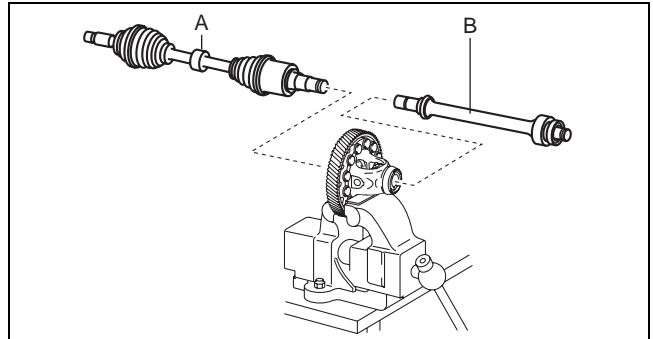

azzjw00001310

26. Remove the ring gear and differential from the vise.

- A : Vise

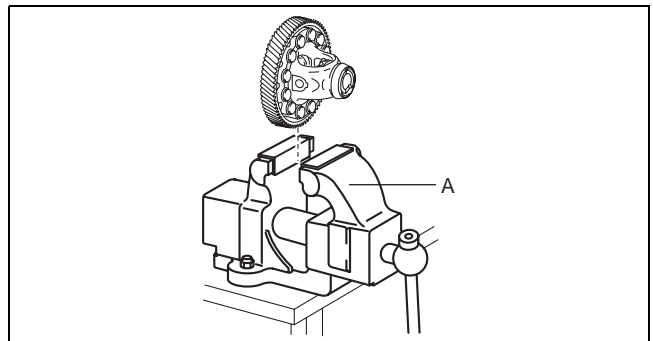

azzjw00001311

AUTOMATIC TRANSAXLE

Differential Backlash Adjustment

1. Remove the dial gauge and magnetic stand.

- A : Dial gauge
- B : Magnetic stand

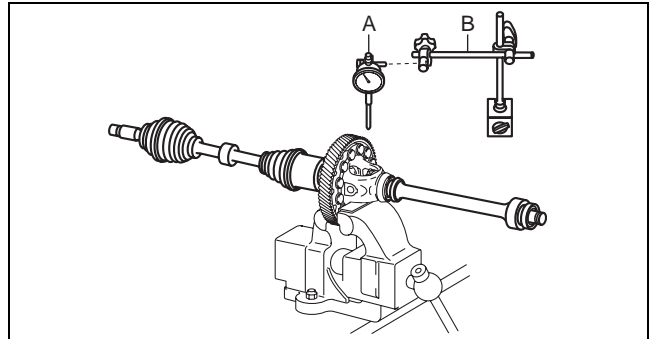

azzjjw00001309

2. Remove the drive shaft (LH) and joint shaft.

- A : Drive shaft (LH)
- B : Joint shaft

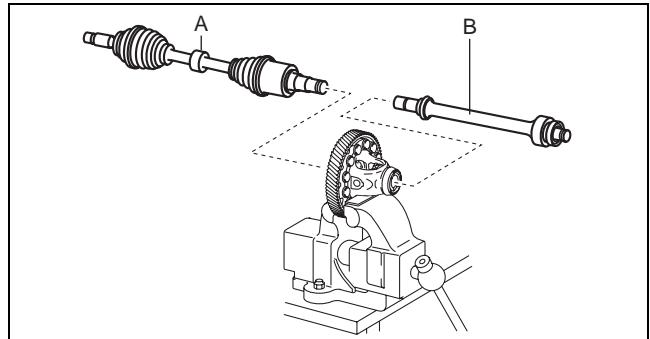

azzjjw00001310

3. Remove the ring gear and differential from the vise.

- A : Vise

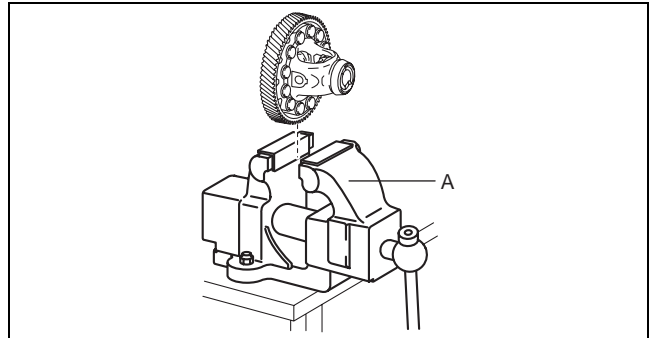

azzjjw00001311

4. Remove the roll pin shown in the figure using a pin punch.

Note

- Use a pin punch with an end outer diameter of 3 mm {0.119 in} or more, and within 4 mm {0.157 in} and an end length of 50 mm {2.0 in} or more.

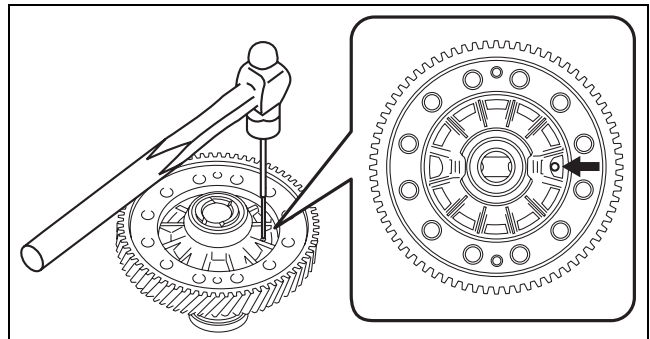

azzjjw00001470

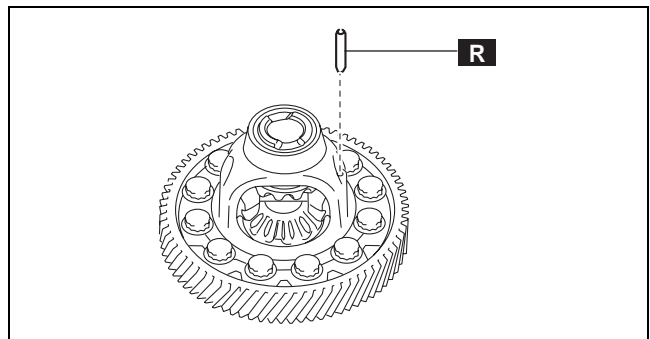

azzjjw00001471

AUTOMATIC TRANSAXLE

5. Remove the pinion shaft.

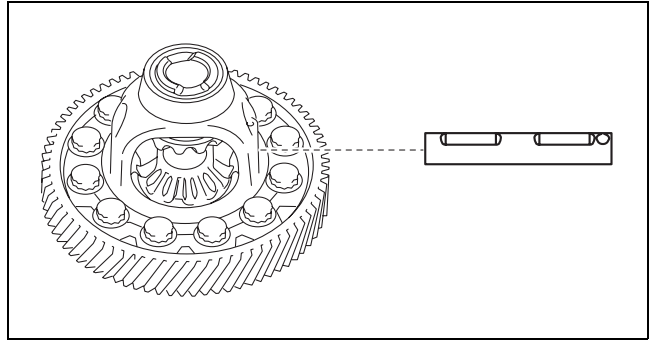

azzjw00001472

6. Remove the pinion gears using the following procedure:

(1) Rotate the pinion gears as shown in the figure.

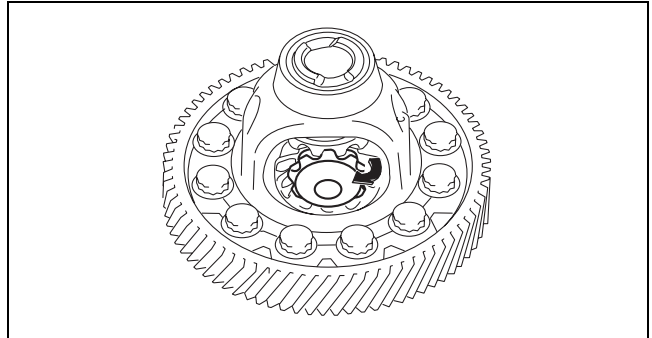

azzjw00001473

(2) Remove the pinion gears.

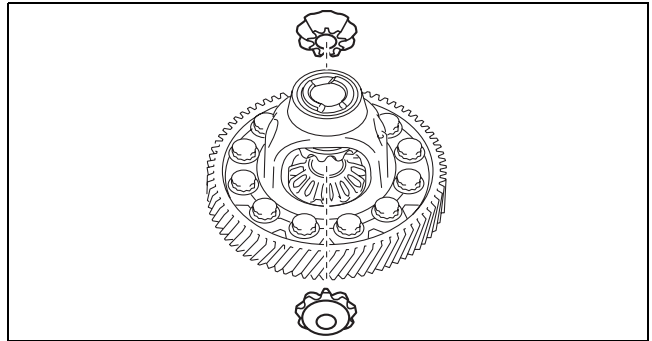

azzjw00001474

7. Remove the thrust washers from the pinion gears.

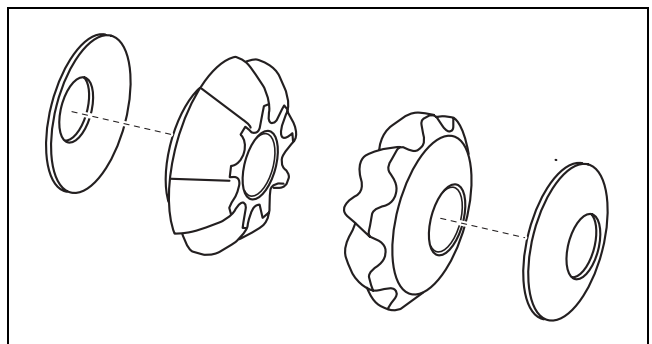

azzjw00001475

AUTOMATIC TRANSAXLE

8. Remove the side gears.

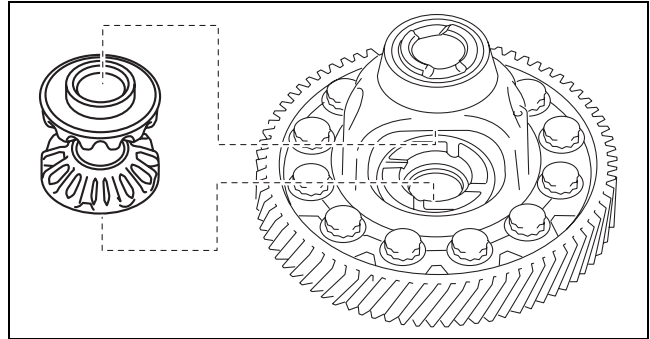

azzjw00001476

05-17

9. Remove the thrust washers from the side gears.

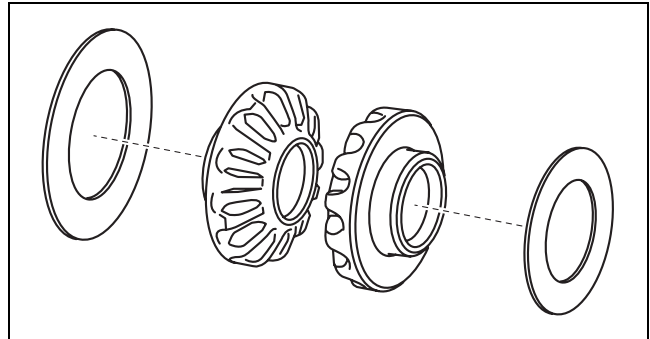

azzjw00001477

10. Measure the thickness of the removed thrust washers from the side gears.

Note

- Recommended measuring instrument: Micrometer

11. Input the measured thrust washer thickness into the measurement/adjustment value input sheet.

12. Perform the following calculation to calculate the differential backlash gap.

Note

- The differential backlash gap is the difference between the differential backlash and the median value of the differential backlash specification.

Differential backlash gap on front side = C - J

C: Differential backlash on front side

J: Median value of differential backlash specification (0.090 mm {0.00354 in})

Note

Example

C: Differential backlash on front side is 0.165 mm {0.00650 in}

Differential backlash gap on front side = 0.165 mm {0.00650 in} - 0.090 mm {0.00354 in} = 0.075 mm {0.00295 in}

Differential backlash gap on rear side = D - J

D: Differential backlash on rear side

J: Median value of differential backlash specification (0.090 mm {0.00354 in})

Note

Example

D: Differential backlash on rear side is 0.155 mm {0.00610 in}

Differential backlash gap on rear side = 0.155 mm {0.00610 in} - 0.090 mm {0.00354 in} = 0.065 mm {0.00256 in}

13. Input the differential backlash gap into the measurement/adjustment value sheet.

AUTOMATIC TRANSAXLE

14. Perform the following calculation to calculate the gap in the thrust washer thickness.

Note

- The gap in the thrust washer thickness is the difference between the removed thrust washer thickness and the optimum thrust washer thickness.
- If the thrust washer thickness is thickened 0.1 mm {0.00394 in}, the differential backlash decreases approx. 0.08 mm {0.00315 in}.

Thrust washer thickness gap on front side = $K \times 0.1 \text{ mm } \{0.00394 \text{ in}\} / 0.08 \text{ mm } \{0.00315 \text{ in}\}$

K: Differential backlash gap on front side

Note

Example

K: Differential backlash gap on front side is 0.075 mm {0.00295 in}

Thrust washer thickness gap on front side = $0.075 \text{ mm } \{0.00295 \text{ in}\} \times 0.1 \text{ mm } \{0.00394 \text{ in}\} / 0.08 \text{ mm } \{0.00315 \text{ in}\} = 0.094 \text{ mm } \{0.00369 \text{ in}\}$

Thrust washer thickness gap on rear side = $L \times 0.1 \text{ mm } \{0.00394 \text{ in}\} / 0.08 \text{ mm } \{0.00315 \text{ in}\}$

L: Differential backlash gap on rear side

Note

Example

L: Differential backlash gap on rear side is 0.065 mm {0.00256 in}

Thrust washer thickness gap on rear side = $0.065 \text{ mm } \{0.00256 \text{ in}\} \times 0.1 \text{ mm } \{0.00394 \text{ in}\} / 0.08 \text{ mm } \{0.00315 \text{ in}\} = 0.081 \text{ mm } \{0.00320 \text{ in}\}$

15. Input the calculated thrust washer thickness gap into the measurement/adjustment value sheet.

16. Perform the following calculation to calculate the optimum thrust washer thickness.

Optimum thrust washer thickness on front side = $H + M$

H: Thickness of removed thrust washer on front side

M: Thrust washer thickness gap on front side

Note

Example

H: Thickness of removed thrust washer on front side is 0.810 mm {0.03189 in}

M: Thrust washer thickness gap on front side is 0.094 mm {0.00369 in}

Thickness of optimum thrust washer on front side = $0.810 \text{ mm } \{0.03189 \text{ in}\} + 0.094 \text{ mm } \{0.00369 \text{ in}\} = 0.904 \text{ mm } \{0.03559 \text{ in}\}$

Thickness of optimum thrust washer on rear side = $I + N$

I: Thickness of removed thrust washer on rear side

N: Thrust washer thickness gap on rear side

Note

Example

I: Thickness of removed thrust washer on rear side is 0.795 mm {0.0313 in}

N: Thrust washer thickness gap on rear side is 0.081 mm {0.00320 in}

Thickness of optimum thrust washer on rear side = $0.795 \text{ mm } \{0.0313 \text{ in}\} + 0.081 \text{ mm } \{0.00320 \text{ in}\} = 0.876 \text{ mm } \{0.03449 \text{ in}\}$

17. Input the calculated optimum thrust washer thickness into the measurement/adjustment value sheet.

AUTOMATIC TRANSAXLE

18. Select the nearest thrust washer for the calculated optimum thrust washer thickness from the following table:

Caution

- **Select the same thickness of the thrust washers on the front and rear sides**
If the thrust washers of the same thickness are assembled on the front and rear sides, measure the differential backlash again, and if the measurement value does not satisfy the specification, thrust washers of varied thickness on the front and rear sides is alright.

Selected thrust washer thickness
0.95 mm {0.037 in}
0.90 mm {0.035 in}
0.85 mm {0.033 in}
0.80 mm {0.031 in}
0.75 mm {0.030 in}

19. Assemble the selected thrust washers to the side gears.

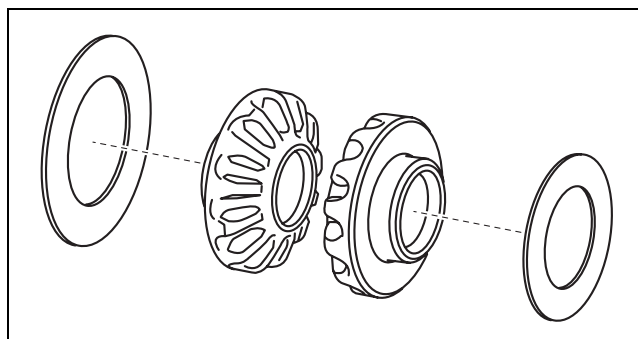

azzjw00001477

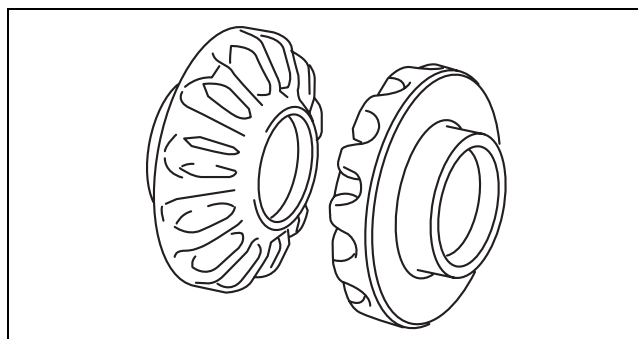

azzjw00001478

AUTOMATIC TRANSAXLE

20. Assemble the side gears which have the thrust washers assembled to them.

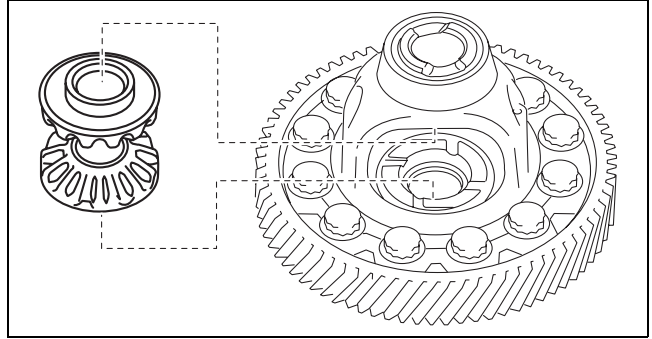

azzjw00001476

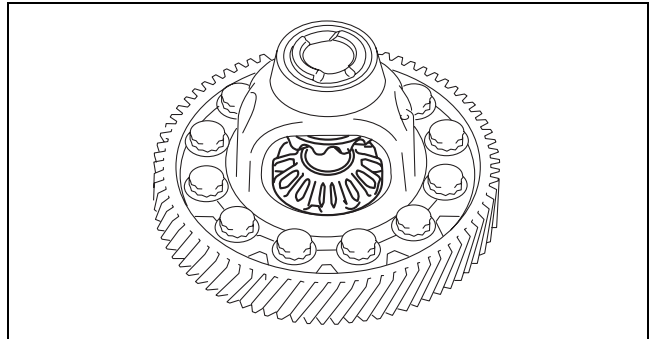

azzjw00001479

21. Assemble the thrust washers to the pinion gears.

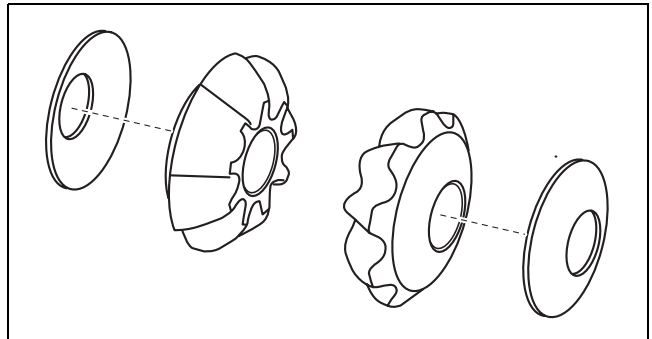

azzjw00001475

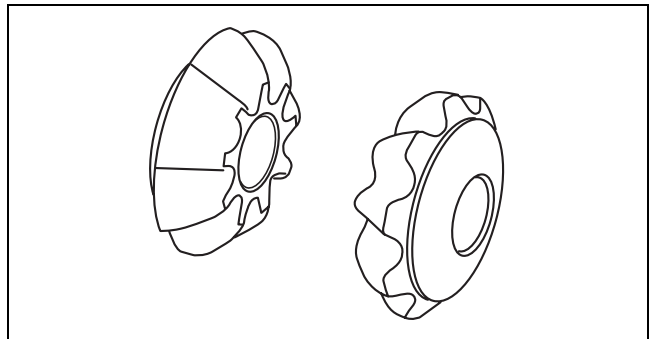

azzjw00001480

AUTOMATIC TRANSAXLE

22. Assemble the pinion gears which have the thrust washers assembled to them using the following procedure:

- (1) Assemble the pinion gears which have the thrust washers assembled to them.

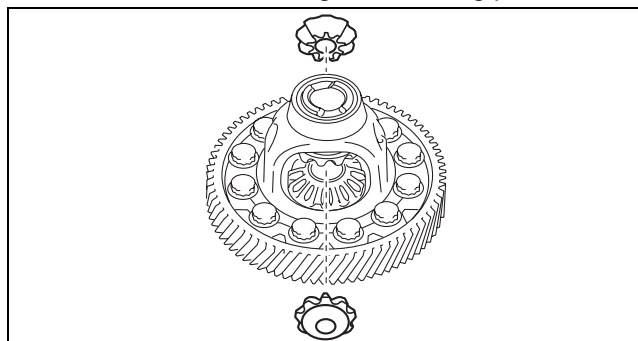

azzjjw00001474

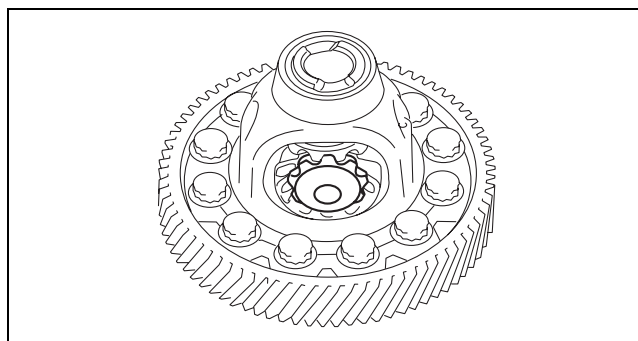

azzjjw00001481

- (2) Rotate the pinion gears so that the pinion shaft holes of the differential gear case and the pinion gears are aligned as shown in the figure.

Note

- If the pinion shaft holes of the differential gear case and the pinion gears are not aligned, remove the pinion gears, change the side gears combination, and reassemble.

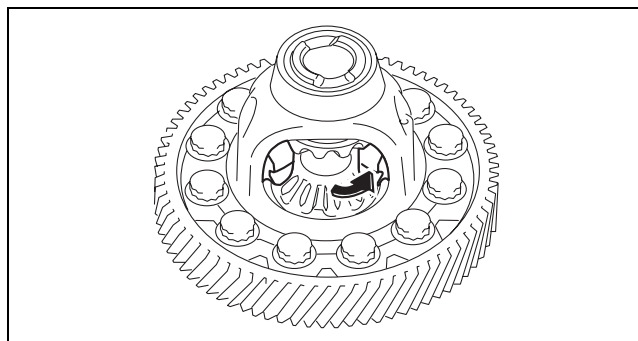

azzjjw00001482

05-17

AUTOMATIC TRANSAXLE

23. Assemble the pinion shaft.

Caution

- Assemble the pinion shaft so that the roll pin holes of the differential gear case and the pinion shaft are aligned.

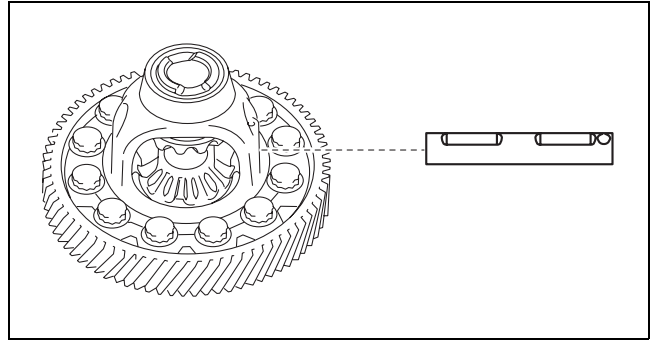

azzjiw00001472

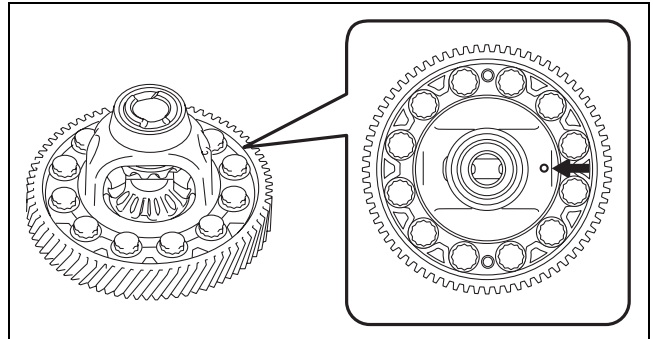

azzjiw00001483

24. Assemble a new roll pin to the position shown in the figure using a pin punch.

Caution

- Assemble so that the end gap of the roll pin is positioned in the direction shown in the figure.

Note

- Use a pin punch with an end outer diameter of 5 mm {0.197 in} or more, and within 8 mm {0.314 in}.

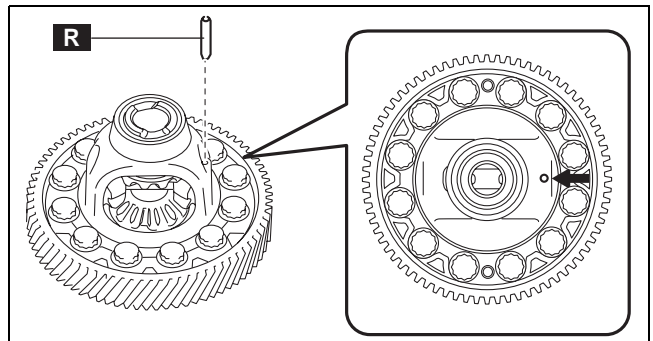

azzjiw00001484

A : -0.5—0.5 mm {-0.01—0.01 in}

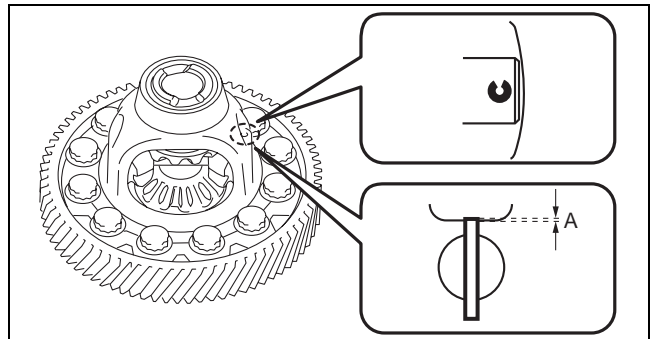

azzjiw00001485

25. Perform the differential backlash measurement. (See 05-17-303 Differential Backlash Measurement.)

AUTOMATIC TRANSAXLE

HIGH CLUTCH CLEARANCE MEASUREMENT/ADJUSTMENT

id051700664600

Preparation Before Servicing

1. Print out the measurement/adjustment value input sheet. (See 05-17-295 MEASUREMENT/ADJUSTMENT VALUE INPUT SHEET.)

Note

- When performing the measurement/adjustment, input the measured and calculated values into the measurement/adjustment value input sheet.
- When performing the other measurements/adjustments, if the measurement/adjustment value input sheet has been printed out, use the printed sheet.

05-17

High Clutch Clearance Measurement

1. Assemble the snap ring.

Caution

- After assembling the snap ring, verify that the snap ring is securely inserted into the bottom of the snap ring groove.

Note

- Snap ring size: Outer diameter approx. 127.4 mm {5.016 in}

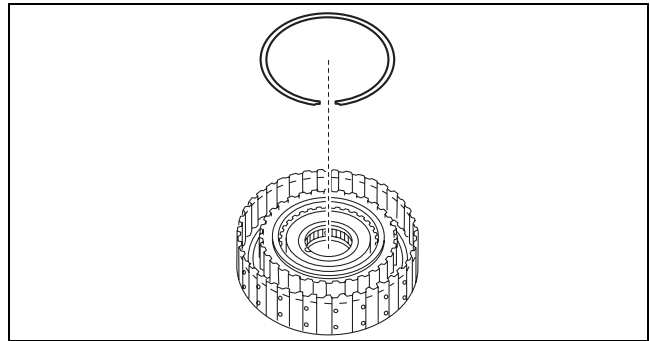

azzjjw00001102

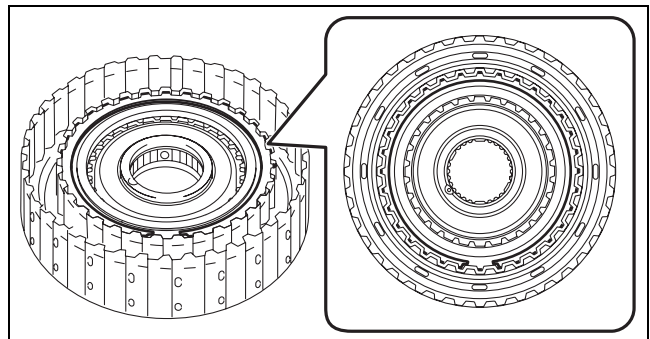

azzjjw00001103

2. Set the oil pump on the workbench as shown in the figure.

A : Rubber plate

Caution

- To reduce error during the high clutch clearance measurement, use the rubber plates to adjust the alignment surface of the oil pump with the transaxle case so that it is level.

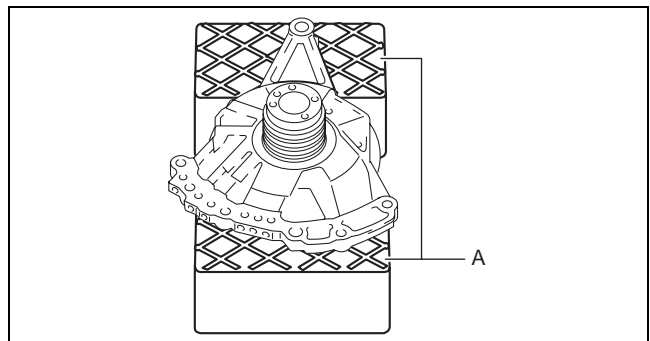

azzjjw00001104

AUTOMATIC TRANSAXLE

3. Assemble the thrust needle bearing to the clutch component using the following procedure:

Note

- Thrust needle bearing size: Outer diameter approx. 72.7 mm {2.86 in}

- (1) To prevent the thrust needle bearing from dropping out, apply ATF (ATF FZ) to the thrust needle bearing.
- (2) Assemble the thrust needle bearing.

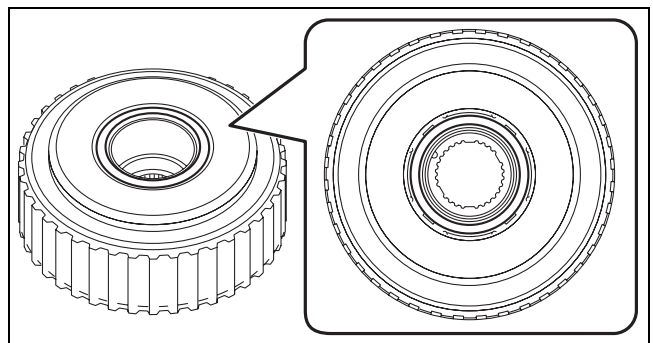
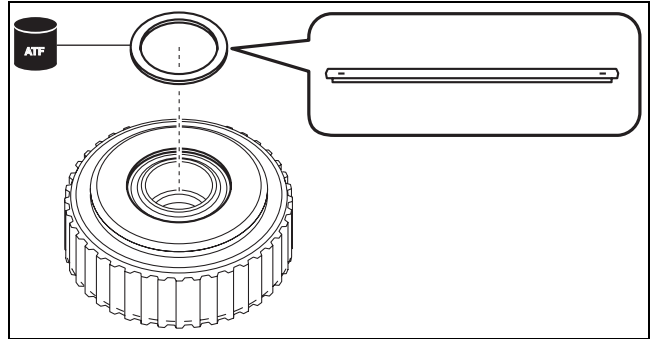

4. Assemble the parts assembled together in Step 3 to the oil pump.

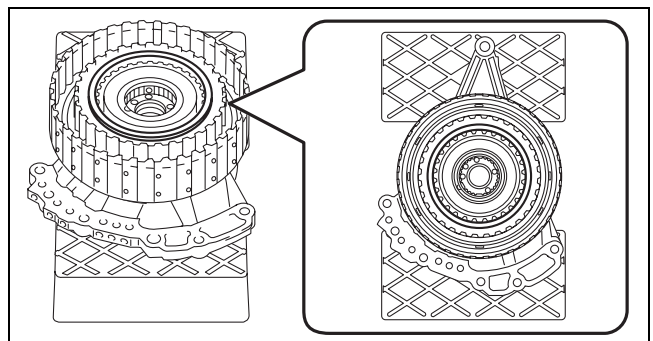
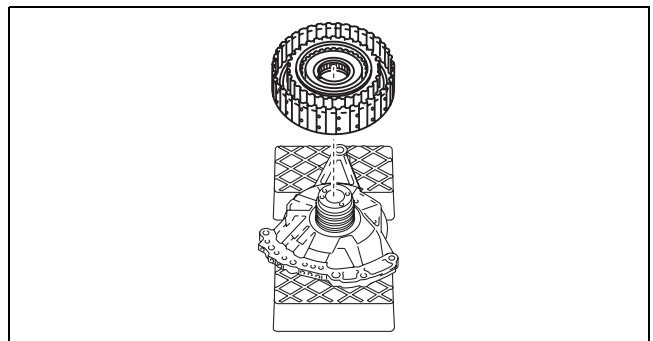

AUTOMATIC TRANSAXLE

5. Install the SST.

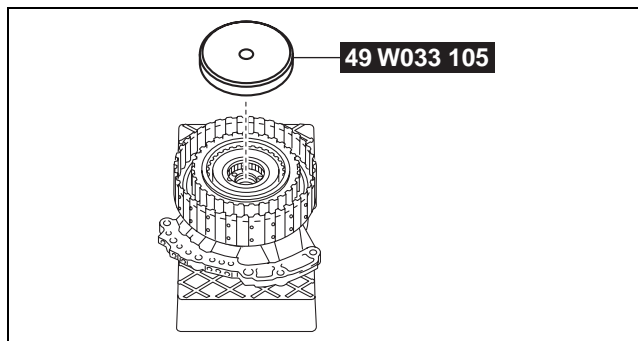

azzijw00001109

05-17

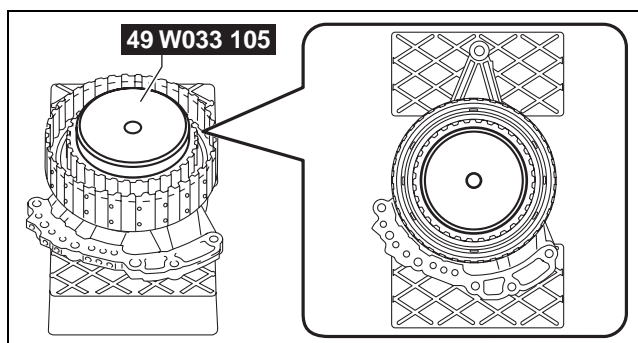

azzijw00001110

6. Place a 98—196 N {10.0—19.9 kgf, 23.0—44.0 lbf} weight on the SST.

A : Weight (V-block)

Caution

- To reduce error during the high clutch clearance measurement, place the weight near the center of the SST.

Note

- Use a V-block as a weight.

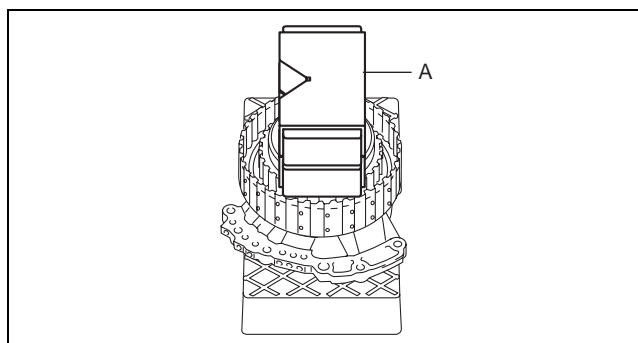

azzijw00001111

AUTOMATIC TRANSAXLE

7. Set the measuring instrument to the oil pump using the following procedure:

- (1) Install an appropriate steel plate for securing the magnetic stand used in the procedure shown in the figure..

1	Steel plate (for securing magnetic stand)
2	Bolt (M8)
3	Nut (M8)

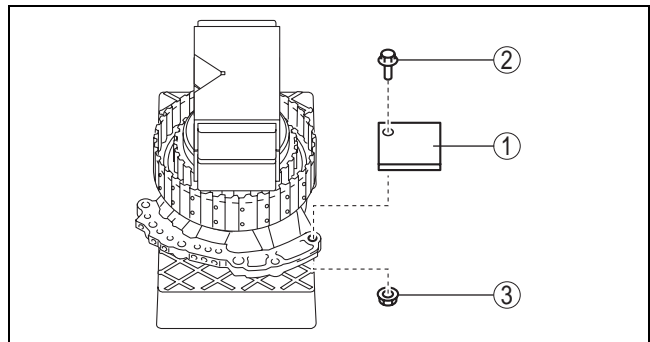

azzjiw00001112

Caution

- If the bolt and nut are tightened with excessive force when installing the steel plate, the alignment surface of the oil pump with the transaxle case could be damaged. Tighten the bolt and nut so that the steel plate does not move during the high clutch clearance measurement.

Note

- When installing the steel plate to the oil pump, use an M8 bolt and nut.

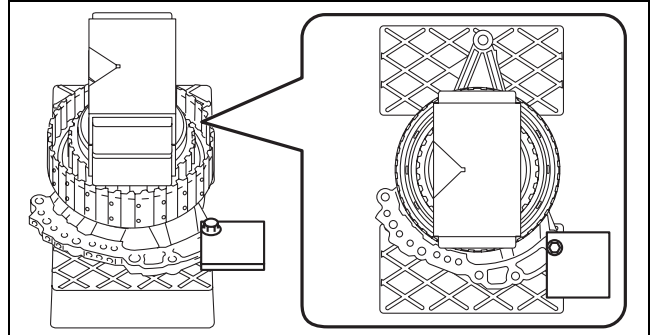

azzjiw00001113

Steel plate installation bolt tightening torque
 15 N·m {1.5 kgf·m, 11 ft·lbf} or less (tighten so that steel plate does not move during high clutch clearance measurement)

- (2) Set the dial gauge and magnetic stand as shown in the figure.

- A : Dial gauge
 B : Magnetic stand

Caution

- To reduce error during the high clutch clearance measurement, set the dial gauge so that it is perpendicular to the alignment surface of the oil pump with the transaxle case.

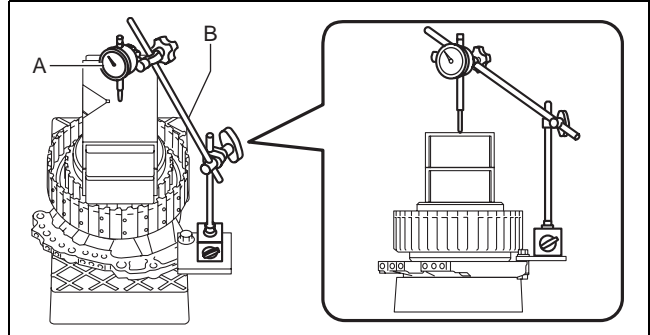

azzjiw00001114

- (3) Set the dial gauge end near the center of the weight.

- A : Area in which dial gauge end is set

Caution

- To reduce error during the high clutch clearance measurement, set the dial gauge end to within the area shown in the figure.

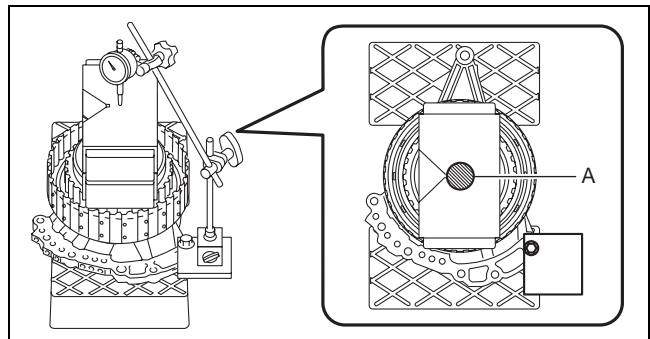

azzjiw00001115

AUTOMATIC TRANSAXLE

8. Measure the high clutch clearance using the following procedure:

- (1) Blow compressed air into the oil passage shown in the figure and verify the operation condition of the high clutch piston (approx. 3 times).

Warning

- Always wear protective eye wear when using the air compressor. Otherwise, ATF or dirt particles blown off by the air compressor could get into the eyes.

Caution

- To prevent damage to parts, always use an air compressor which is adjusted to the indicated pressure.

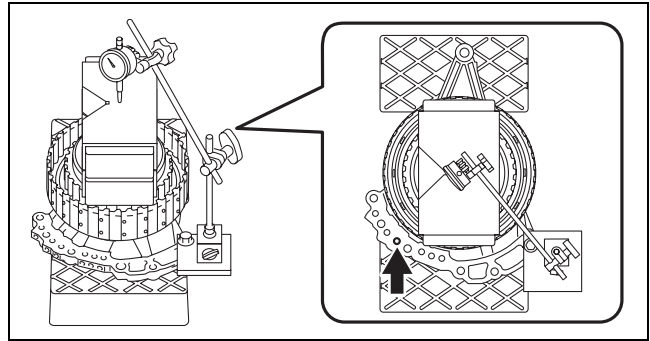

05-17

Compressed air pressure

0.39—0.44 MPa {4.0—4.4 kgf/cm², 57—63 psi}

- (2) Blow compressed air into the oil passage shown in the figure and operate the high clutch piston to read the value when the dial gauge is stabilized.

Warning

- Always wear protective eye wear when using the air compressor. Otherwise, ATF or dirt particles blown off by the air compressor could get into the eyes.

Caution

- To prevent damage to parts, always use an air compressor which is adjusted to the indicated pressure.

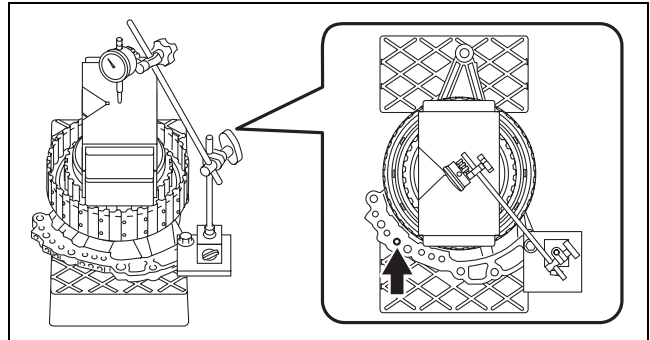

Compressed air pressure

0.39—0.44 MPa {4.0—4.4 kgf/cm², 57—63 psi}

- (3) Input the dial gauge value, which was read while the high clutch piston was operating, into the measurement/adjustment value input sheet.
- (4) Release the compressed air and read the dial gauge value without the high clutch piston operating.
- (5) Input the dial gauge value, which was read without the high clutch piston operating, into the measurement/adjustment value input sheet.
- (6) Perform the following calculation to calculate the high clutch clearance.

High clutch clearance = A - B

A: Dial gauge value with high clutch piston operated

B: Dial gauge value without high clutch piston operated

Note

Example

A: Dial gauge value with high clutch piston operating is 1.605 mm {0.06319 in}

B: Dial gauge value without high clutch piston operating is 0.055 mm {0.00217 in}

High clutch clearance = 1.605 mm {0.06319 in} - 0.055 mm {0.00217 in} = 1.550 mm {0.06102 in}

- (7) Input the calculated high clutch clearance into the measurement/adjustment value input sheet.
- (8) Verify that the high clutch clearance satisfies the specification.

Specification

1.300—1.500 mm {0.05119—0.05905 in}

- If not within the specification, adjust the high clutch clearance. (See 05-17-324 High Clutch Clearance Adjustment.)

AUTOMATIC TRANSAXLE

9. Remove the dial gauge and magnetic stand.

- A : Dial gauge
- B : Magnetic stand

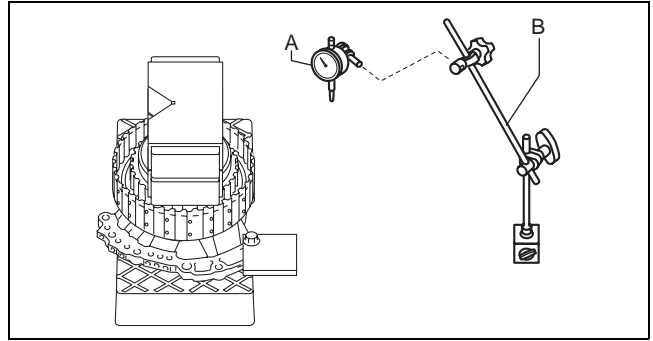

azzjiw00001117

10. Remove the steel plate for securing the magnetic stand using the procedure shown in the figure.

1	Nut (M8)
2	Bolt (M8)
3	Steel plate (for securing magnetic stand)

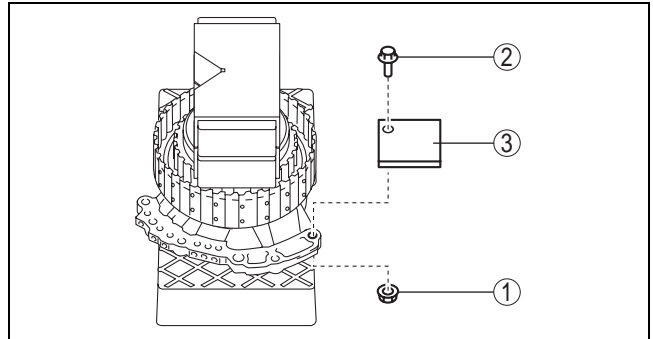

azzjiw00001118

11. Remove the weight on the SST.

- A : Weight (V-block)

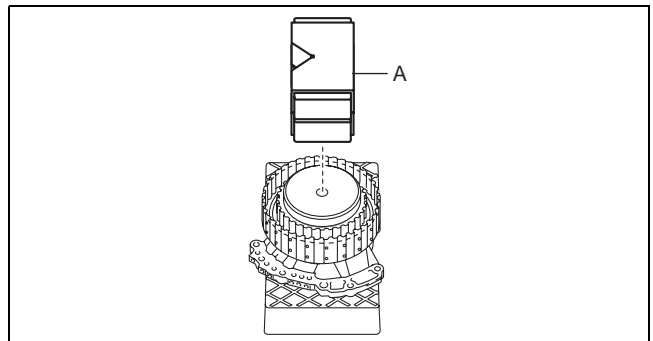

azzjiw00001119

12. Remove the SST.

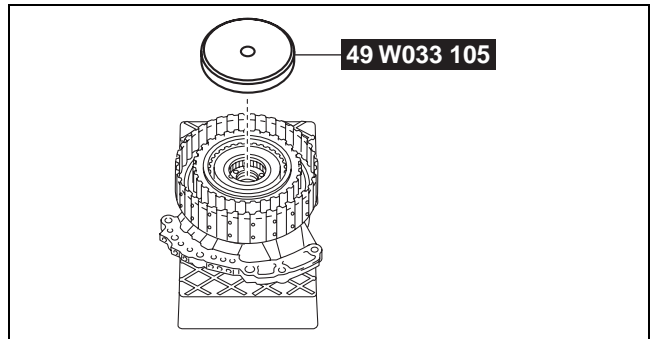

azzjiw00001109

AUTOMATIC TRANSAXLE

13. Remove the clutch component.

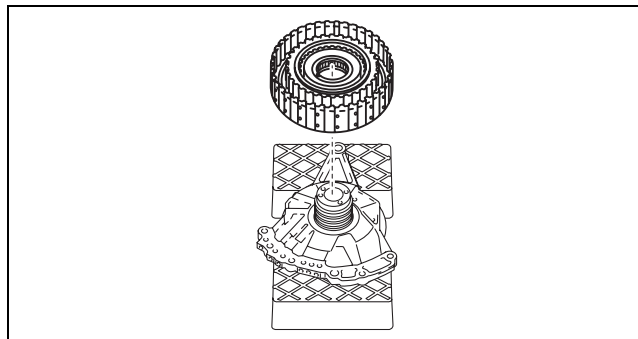

azzijw00001107

05-17

14. Remove the thrust needle bearing.

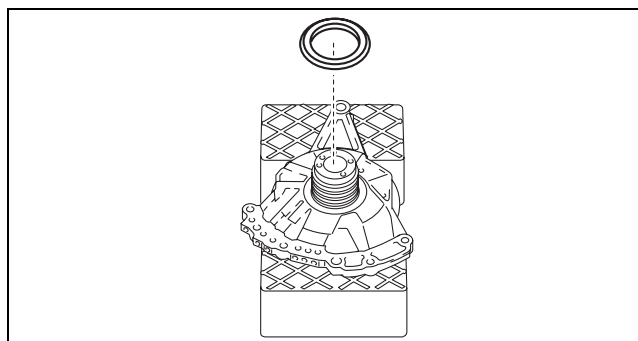

azzijw00001120

15. Take the oil pump off the rubber plates.

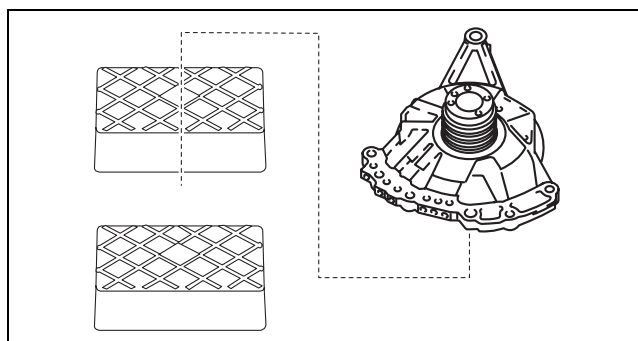

azzijw00001121

AUTOMATIC TRANSAXLE

High Clutch Clearance Adjustment

1. Remove the dial gauge and magnetic stand.

- A : Dial gauge
- B : Magnetic stand

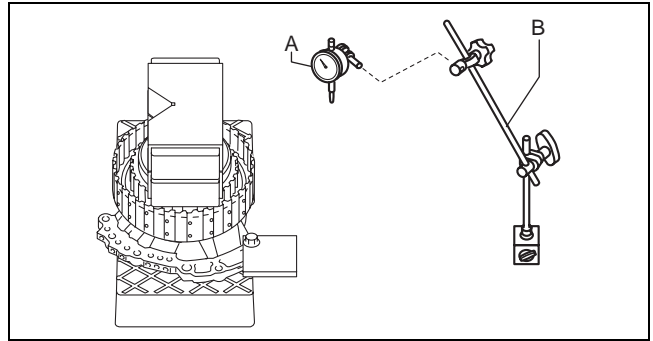

azzjiw00001117

2. Remove the weight on the SST.

- A : Weight (V-block)

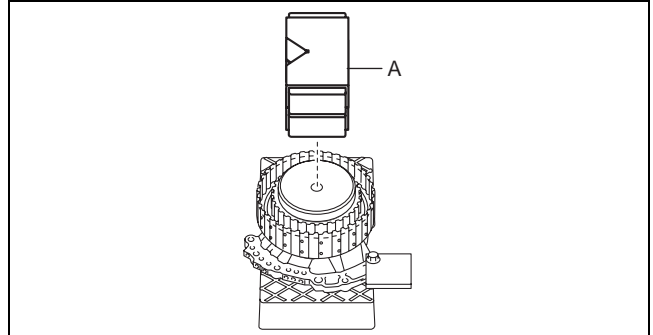

azzjiw00001122

3. Remove the SST.

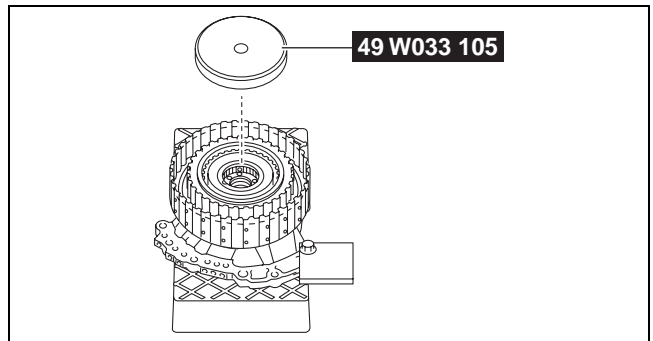

azzjiw00001123

4. Remove the snap ring.

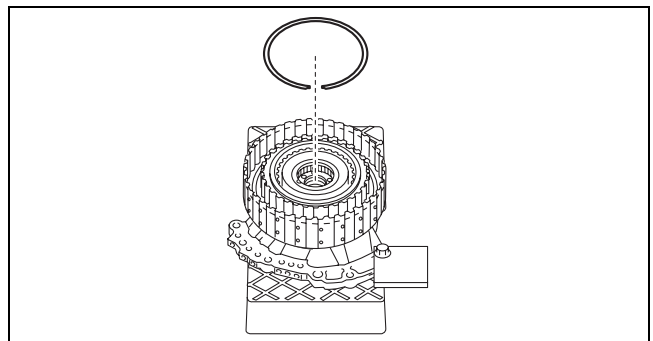

azzjiw00001124

5. Measure the thickness of the removed snap ring.

Note

- Recommended measuring instrument: Micrometer

6. Input the measured snap ring thickness into the measurement/adjustment value input sheet.

AUTOMATIC TRANSAXLE

7. Select the appropriate snap ring from the following table:

Range*	Selected snap ring thickness
Exceeds 3.450 mm {0.1358 in}, 3.550 mm {0.1398 in} or less	2.1 mm {0.083 in}
Exceeds 3.350 mm {0.1319 in}, 3.450 mm {0.1358 in} or less	2.0 mm {0.079 in}
Exceeds 3.250 mm {0.1280 in}, 3.350 mm {0.1319 in} or less	1.9 mm {0.075 in}
Exceeds 3.150 mm {0.1240 in}, 3.250 mm {0.1280 in} or less	1.8 mm {0.071 in}
Exceeds 3.050 mm {0.1201 in}, 3.150 mm {0.1240 in} or less	1.7 mm {0.067 in}
Exceeds 2.950 mm {0.1161 in}, 3.050 mm {0.1201 in} or less	1.6 mm {0.063 in}
Exceeds 2.850 mm {0.1122 in}, 2.950 mm {0.1161 in} or less	1.5 mm {0.059 in}
Exceeds 2.750 mm {0.1083 in}, 2.850 mm {0.1122 in} or less	1.4 mm {0.055 in}
Exceeds 2.650 mm {0.1043 in}, 2.750 mm {0.1083 in} or less	1.3 mm {0.051 in}
Exceeds 2.550 mm {0.1004 in}, 2.650 mm {0.1043 in} or less	1.2 mm {0.047 in}

* : The range is the sum of the high clutch clearance and the thickness value of the removed snap ring.

Range = C + F

C: High clutch clearance

F: Thickness of removed snap ring

Note

Example

C: High clutch clearance is 1.550 mm {0.06102 in}

F: Thickness of removed snap ring is 1.615 mm {0.06358 in}

Range = 1.550 mm {0.06102 in} + 1.615 mm {0.06358 in} = 3.165 mm {0.1246 in}, the selected snap ring has a thickness of 1.8 mm {0.071 in}.

8. Assemble the selected snap ring.

Caution

- After assembling the snap ring, verify that the snap ring is securely inserted into the bottom of the snap ring groove.

Note

- Snap ring size: Outer diameter approx. 127.4 mm {5.016 in}

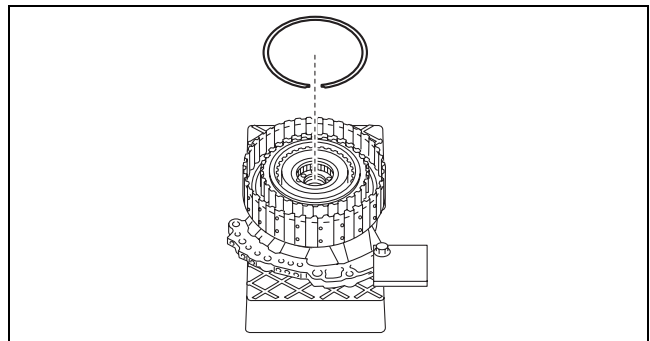

azzjw00001124

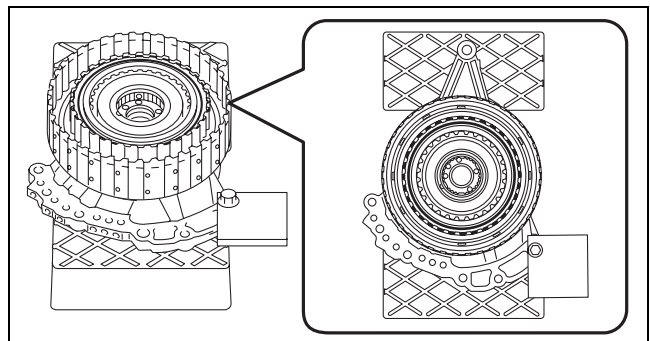

azzjw00001125

AUTOMATIC TRANSAXLE

9. Install the SST.

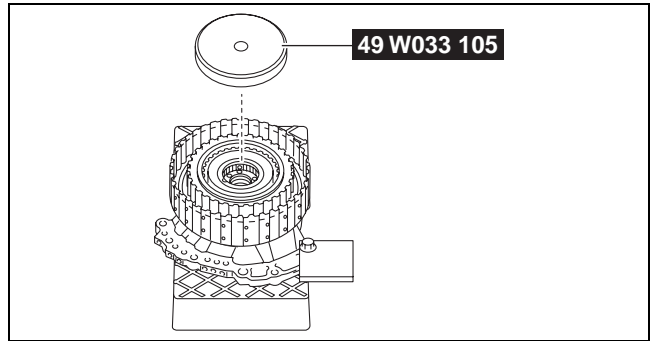

azzjw00001123

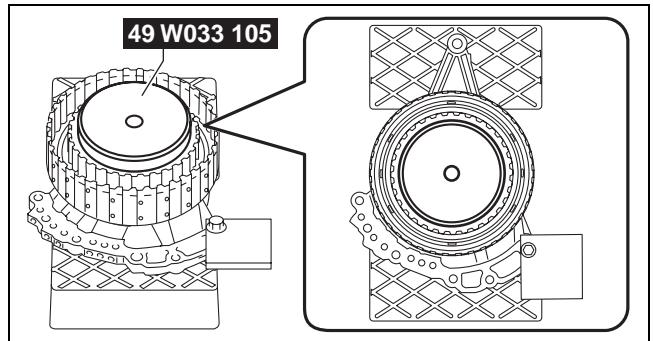

azzjw00001126

10. Place a 98—196 N {10.0—19.9 kgf, 23.0—44.0 lbf} weight on the SST.

A : Weight (V-block)

Caution

- To reduce error during the high clutch clearance measurement, place the weight near the center of the SST.

Note

- Use a V-block as a weight.

11. Perform the high clutch clearance measurement from Step 7 (2). (See 05-17-317 High Clutch Clearance Measurement.)

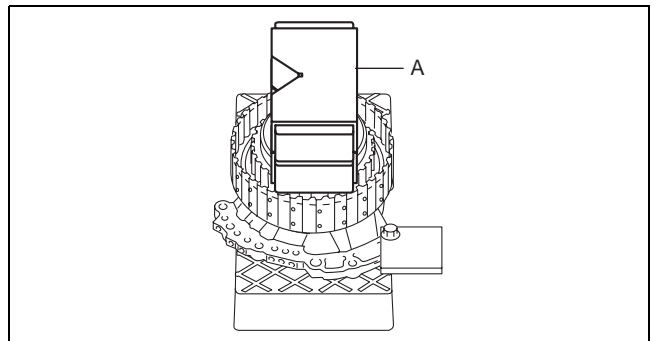

azzjw00001127

AUTOMATIC TRANSAXLE

LOW CLUTCH CLEARANCE MEASUREMENT/ADJUSTMENT

id051700664500

Preparation Before Servicing

1. Print out the measurement/adjustment value input sheet. (See 05-17-295 MEASUREMENT/ADJUSTMENT VALUE INPUT SHEET.)

Note

- When performing the measurement/adjustment, input the measured and calculated values into the measurement/adjustment value input sheet.
- When performing the other measurements/adjustments, if the measurement/adjustment value input sheet has been printed out, use the printed sheet.

05-17

Low Clutch Clearance Measurement

1. Assemble the snap ring to the position shown in the figure.

Caution

- Assemble so that the end gap of the snap ring is positioned diagonally opposed to the end gap of the snap ring for the high clutch.
- After assembling the snap ring, verify that the snap ring is securely inserted into the bottom of the snap ring groove.

Note

- Snap ring size: Outer diameter approx. 169.3 mm {6.665 in}

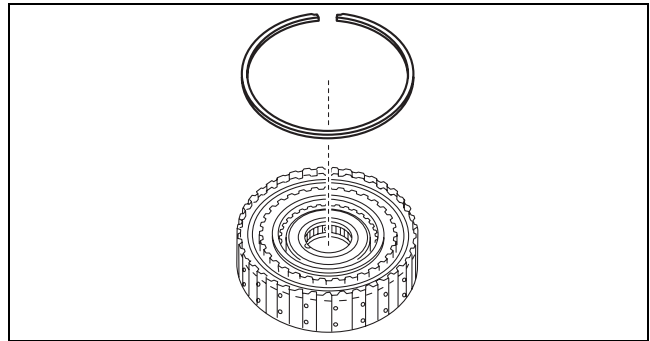

azzjjw00001075

- A : Snap ring (low clutch)
B : Snap ring (high clutch)

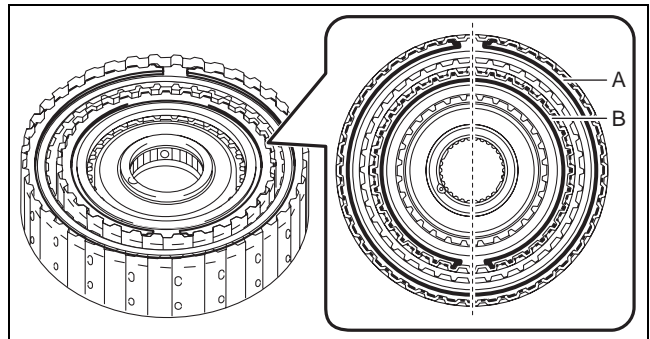

azzjjw00001076

2. Set the oil pump on the workbench as shown in the figure.

- A : Rubber plate

Caution

- To reduce error during the low clutch clearance measurement, use the rubber plates to adjust the alignment surface of the oil pump with the transaxle case so that it is level.

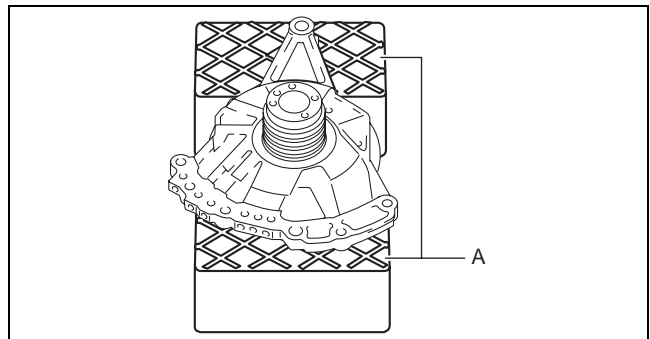

azzjjw00001077

AUTOMATIC TRANSAXLE

3. Assemble the thrust needle bearing to the clutch component using the following procedure:

Note

- Thrust needle bearing size: Outer diameter approx. 72.7 mm {2.86 in}

- (1) To prevent the thrust needle bearing from dropping out, apply ATF (ATF FZ) to the thrust needle bearing.
- (2) Assemble the thrust needle bearing.

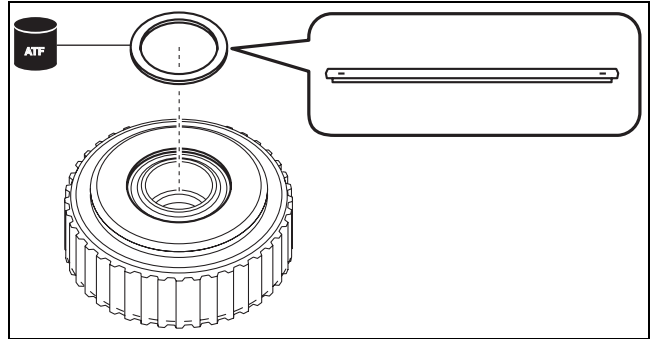

azzjiw00001078

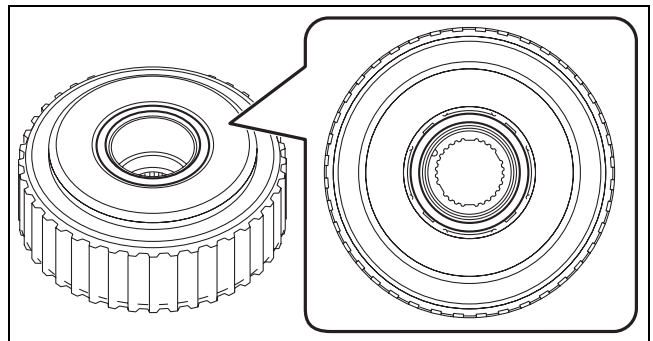

azzjiw00001079

4. Assemble the parts assembled together in Step 3 to the oil pump.

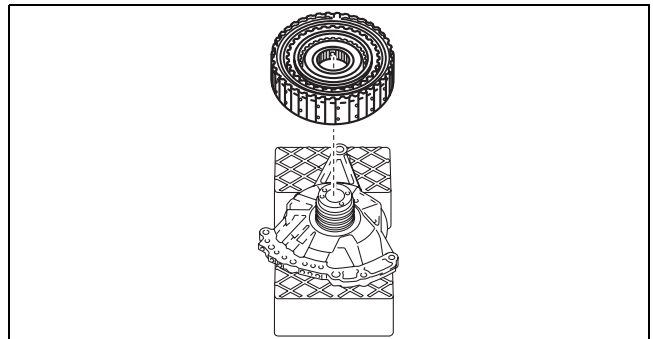

azzjiw00001080

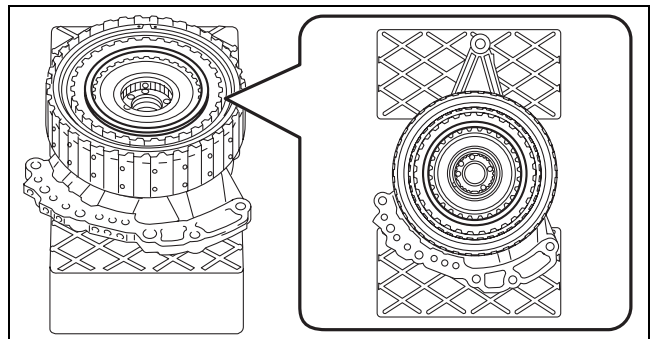

azzjiw00001081

AUTOMATIC TRANSAXLE

5. Install the SST.

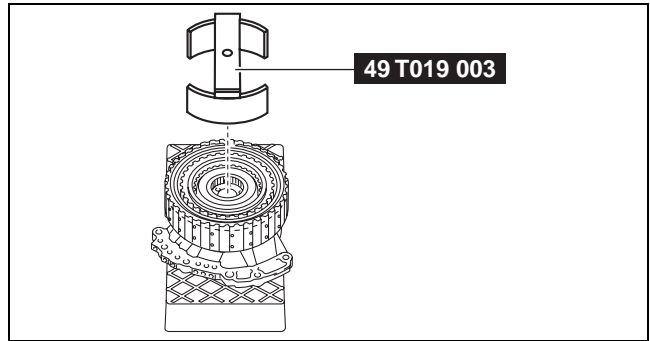

azzjw00001082

05-17

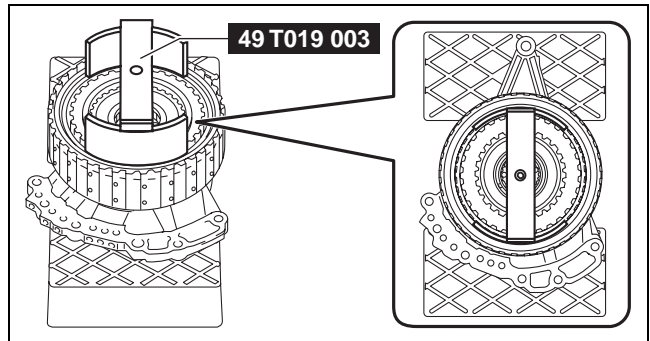

azzjw00001083

6. Place a 98—196 N {10.0—19.9 kgf, 23.0—44.0 lbf} weight on the SST using the following procedure:

Note

- Use a V-block as a weight.

- (1) Measure the weight of the weight placed on the SST.
- (2) Input the measured weight into the measurement/adjustment value input sheet.
- (3) Place the measured weight on the SST.

A : Weight (V-block)

Caution

- To reduce error during the low clutch clearance measurement, place the weight near the center of the SST.

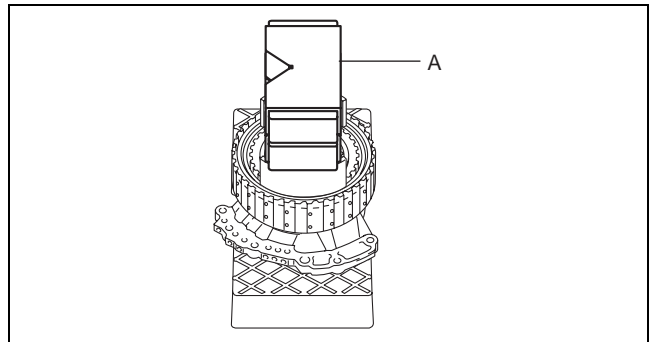

azzjw00001084

AUTOMATIC TRANSAXLE

7. Perform the following calculation to calculate the correction value for the low clutch clearance.

Note

- Because a wave spring is included in the low clutch, a correction value is required for the low clutch clearance according to the weight of the weight used during the low clutch clearance measurement.

Correction value of low clutch clearance (weight of unit is N) = (A - 90 N) × 0.00157 mm {0.0000618 in}

A: Weight of weight

Note

Example

A: Weight of weight is 150 N

Correction value of low clutch clearance = (150 N - 90 N) × 0.00157 mm {0.0000618 in} = 0.0942 mm {0.00371 in}

Correction value of low clutch clearance (weight of unit is kgf) = (A - 9.18 kgf) × 0.01540 mm {0.0006063 in}

A: Weight of weight

Note

Example

A: Weight of weight is 15.30 kgf

Correction value of low clutch clearance = (15.30 kgf - 9.18 kgf) × 0.01540 mm {0.0006063 in} = 0.0942 mm {0.00371 in}

Correction value of low clutch clearance (weight of unit is lbf) = (A - 20.23 lbf) × 0.00698 mm {0.0002748 in}

A: Weight of weight

Note

Example

A: Weight of weight is 33.72 lbf

Correction value of low clutch clearance = (33.72 lbf - 20.23 lbf) × 0.00698 mm {0.0002748 in} = 0.0942 mm {0.00371 in}

8. Input the calculated correction value of the low clutch clearance into the measurement/adjustment value input sheet.

AUTOMATIC TRANSAXLE

9. Set the measuring instrument to the oil pump using the following procedure:

- (1) Install an appropriate steel plate for securing the magnetic stand used in the procedure shown in the figure..

1	Steel plate (for securing magnetic stand)
2	Bolt (M8)
3	Nut (M8)

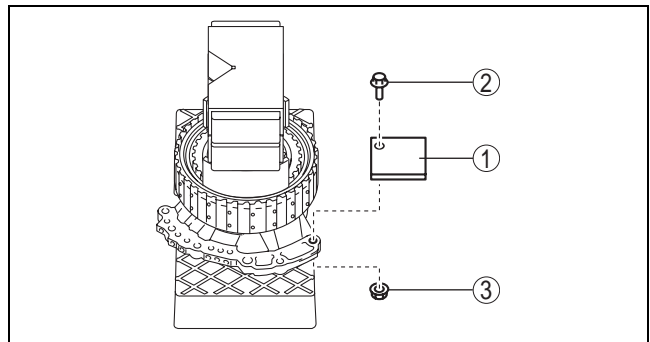

azzjjw00001085

05-17

Caution

- If the bolt and nut are tightened with excessive force when installing the steel plate, the alignment surface of the oil pump with the transaxle case could be damaged. Tighten the bolt and nut so that the steel plate does not move during low clutch clearance measurement.

Note

- When installing the steel plate to the oil pump, use an M8 bolt and nut.

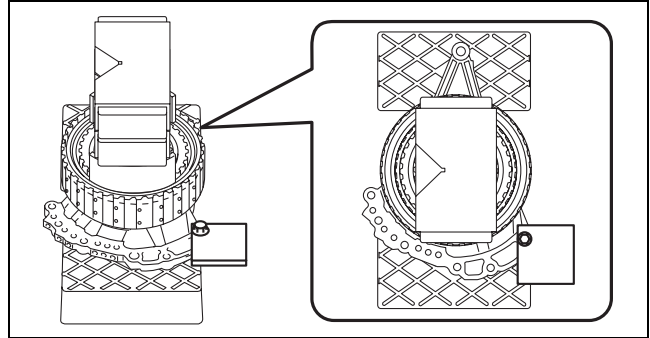

azzjjw00001086

Steel plate installation bolt tightening torque

15 N·m {1.5 kgf·m, 11 ft·lbf} or less (tighten so that steel plate does not move during low clutch clearance measurement)

- (2) Set the dial gauge and magnetic stand as shown in the figure.

- A : Dial gauge
B : Magnetic stand

Caution

- To reduce error during the low clutch clearance measurement, set the dial gauge so that it is perpendicular to the alignment surface of the oil pump with the transaxle case.

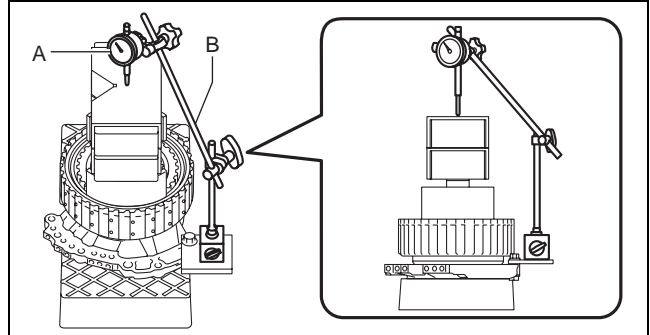

azzjjw00001087

- (3) Set the dial gauge end near the center of the weight.

- A : Area in which dial gauge end is set

Caution

- To reduce error during the low clutch clearance measurement, set the dial gauge end to within the area shown in the figure.

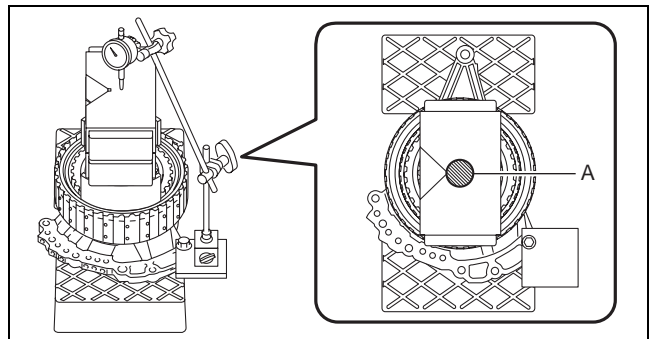

azzjjw00001088

AUTOMATIC TRANSAXLE

10. Measure the low clutch clearance using the following procedure:

- (1) Blow compressed air into the oil passage shown in the figure and verify the operation condition of the low clutch piston (approx. 3 times).

Warning

- Always wear protective eye wear when using the air compressor. Otherwise, ATF or dirt particles blown off by the air compressor could get into the eyes.

Caution

- To prevent damage to parts, always use an air compressor which is adjusted to the indicated pressure.

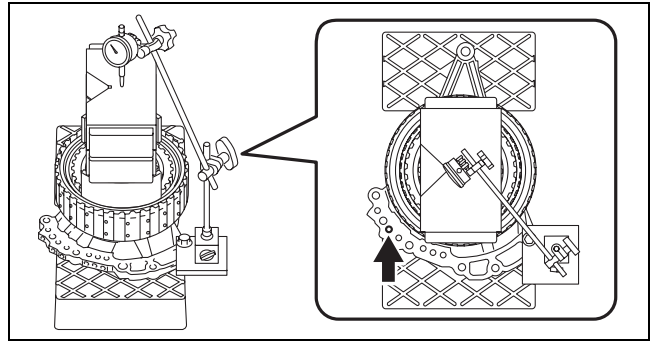

azzjiw00001089

Compressed air pressure

0.39—0.44 MPa {4.0—4.4 kgf/cm², 57—63 psi}

- (2) Blow compressed air into the oil passage shown in the figure and operate the low clutch piston to read the value when the dial gauge is stabilized.

Warning

- Always wear protective eye wear when using the air compressor. Otherwise, ATF or dirt particles blown off by the air compressor could get into the eyes.

Caution

- To prevent damage to parts, always use an air compressor which is adjusted to the indicated pressure.

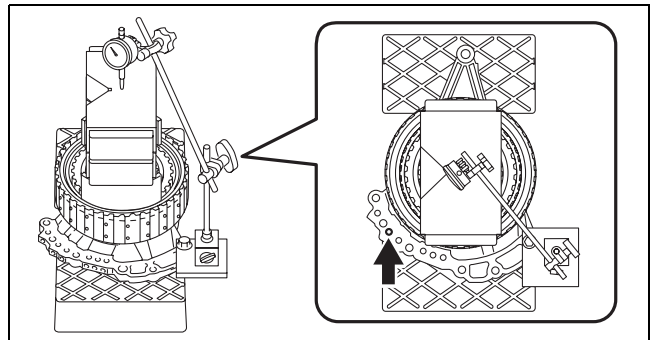

azzjiw00001089

Compressed air pressure

0.39—0.44 MPa {4.0—4.4 kgf/cm², 57—63 psi}

- (3) Input the dial gauge value, which was read while the low clutch piston was operating, into the measurement/adjustment value input sheet.
- (4) Release the compressed air and read the dial gauge value without the low clutch piston operating.
- (5) Input the dial gauge value, which was read without the low clutch piston operating, into the measurement/adjustment value input sheet.
- (6) Perform the following calculation to calculate the low clutch clearance.

Low clutch clearance = C - D - B

B: Correction value of low clutch clearance

C: Dial gauge value with low clutch piston operated

D: Dial gauge value without low clutch piston operated

Note

Example

B: Correction value of low clutch clearance is 0.0942 mm {0.00371 in}

C: Dial gauge value with low clutch piston operated is 2.320 mm {0.09134 in}

D: Dial gauge value without low clutch piston operated is 0.595 mm {0.02343 in}

Low clutch clearance = 2.320 mm {0.09134 in} - 0.595 mm {0.02343 in} - 0.0942 mm {0.00371 in}
= 1.6308 mm {0.06420 in}

- (7) Input the calculated low clutch clearance into the measurement/adjustment value input sheet.

AUTOMATIC TRANSAXLE

(8) Verify that the low clutch clearance satisfies the specification.

Specification

1.400—1.600 mm {0.05512—0.06299 in}

- If not within the specification, adjust the low clutch clearance. (See 05-17-335 Low Clutch Clearance Adjustment.)

11. Remove the dial gauge and magnetic stand.

A : Dial gauge

B : Magnetic stand

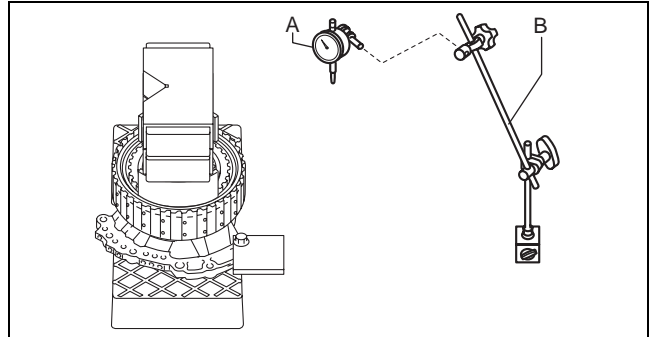

azzjjw00001090

12. Remove the steel plate for securing the magnetic stand using the procedure shown in the figure.

1	Nut (M8)
2	Bolt (M8)
3	Steel plate (for securing magnetic stand)

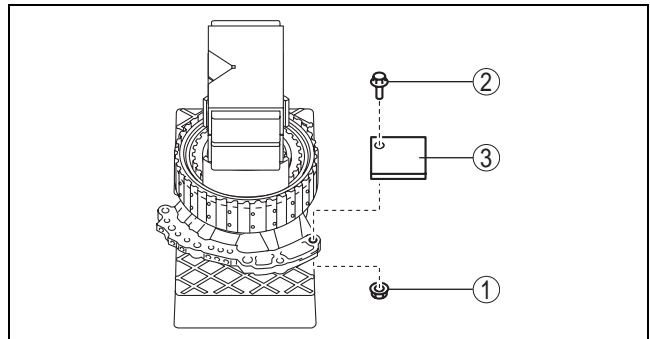

azzjjw00001091

13. Remove the weight on the SST.

A : Weight (V-block)

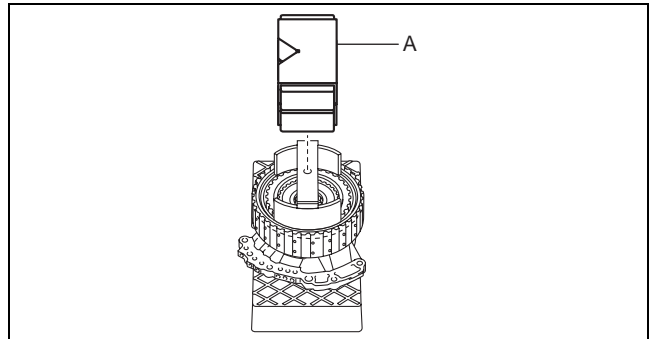

azzjjw00001092

14. Remove the SST.

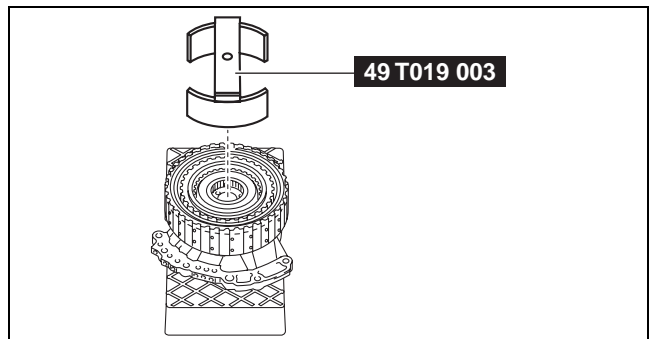

azzjjw00001082

05-17

AUTOMATIC TRANSAXLE

15. Remove the clutch component.

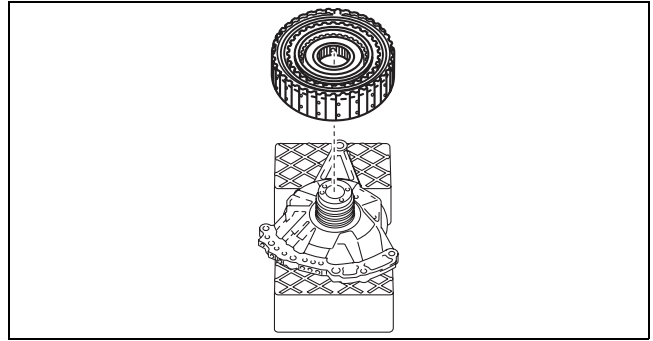

azzijw00001093

16. Remove the thrust needle bearing.

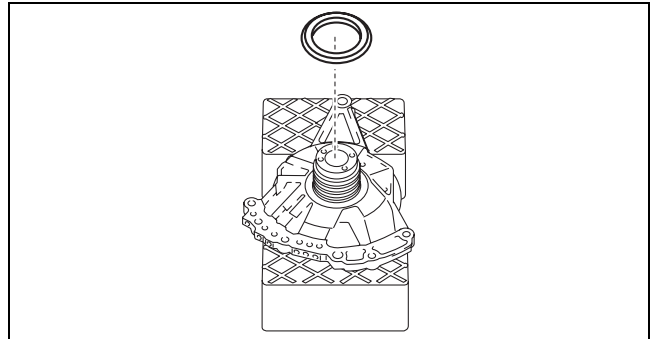

azzijw00001094

17. Take the oil pump off the rubber plates.

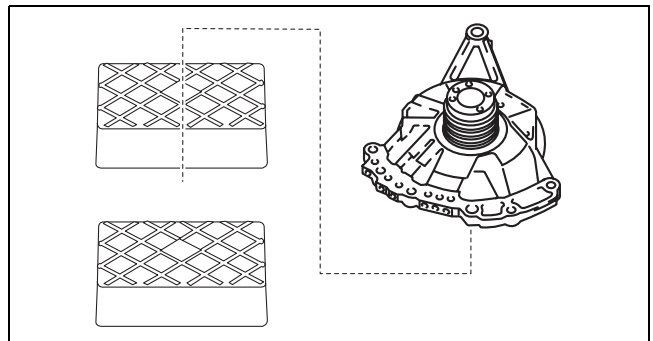

azzijw00001095

AUTOMATIC TRANSAXLE

Low Clutch Clearance Adjustment

1. Remove the dial gauge and magnetic stand.

- A : Dial gauge
- B : Magnetic stand

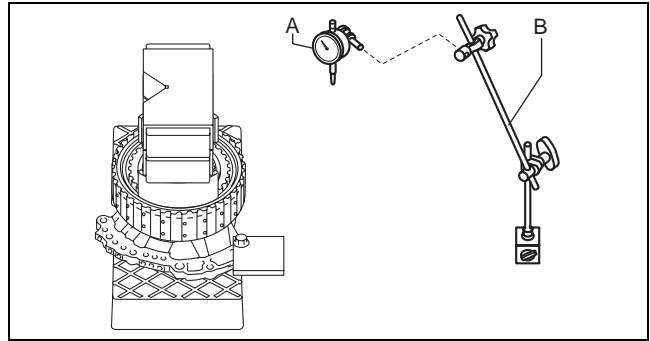

azzjjw00001090

05-17

2. Remove the weight on the SST.

- A : Weight (V-block)

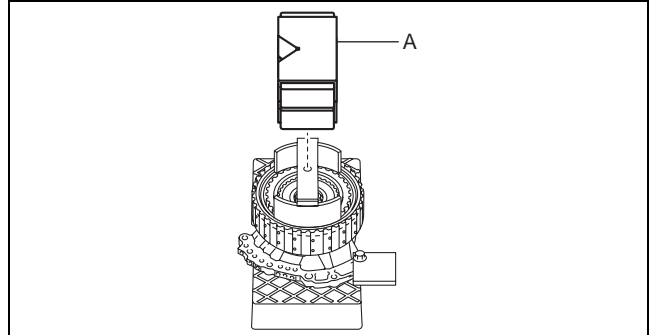

azzjjw00001096

3. Remove the SST.

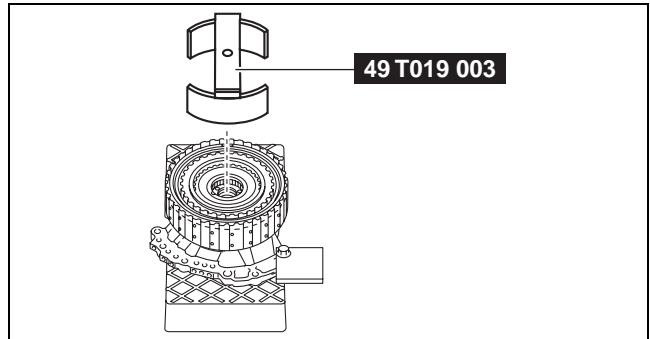

azzjjw00001097

4. Remove the snap ring.

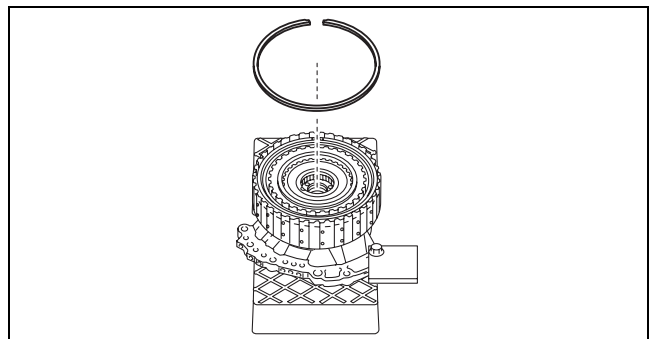

azzjjw00001098

5. Measure the thickness of the removed snap ring.

Note

- Recommended measuring instrument: Micrometer

6. Input the measured snap ring thickness into the measurement/adjustment value input sheet.

AUTOMATIC TRANSAXLE

7. Select the appropriate snap ring from the following table:

Range*	Selected snap ring thickness
Exceeds 3.650 mm {0.14370 in}, 3.750 mm {0.14764 in} or less	2.2 mm {0.087 in}
Exceeds 3.550 mm {0.13976 in}, 3.650 mm {0.14370 in} or less	2.1 mm {0.083 in}
Exceeds 3.450 mm {0.13583 in}, 3.550 mm {0.13976 in} or less	2.0 mm {0.079 in}
Exceeds 3.350 mm {0.13189 in}, 3.450 mm {0.13583 in} or less	1.9 mm {0.075 in}
Exceeds 3.250 mm {0.12795 in}, 3.350 mm {0.13189 in} or less	1.8 mm {0.071 in}
Exceeds 3.150 mm {0.12402 in}, 3.250 mm {0.12795 in} or less	1.7 mm {0.067 in}
Exceeds 3.050 mm {0.12008 in}, 3.150 mm {0.12402 in} or less	1.6 mm {0.063 in}
Exceeds 2.950 mm {0.11614 in}, 3.050 mm {0.12008 in} or less	1.5 mm {0.059 in}
Exceeds 2.850 mm {0.11220 in}, 2.950 mm {0.11614 in} or less	1.4 mm {0.055 in}
Exceeds 2.750 mm {0.10827 in}, 2.850 mm {0.11220 in} or less	1.3 mm {0.051 in}

* : The range is the sum of the low clutch clearance and the thickness value of the removed snap ring.

Range = E + H

E: Low clutch clearance

H: Thickness of removed snap ring

Note

Example

E: Low clutch clearance is 1.6308 mm {0.06420 in}

H: Thickness of removed snap ring is 1.705 mm {0.06713 in}

Range = 1.6308 mm {0.06420 in} + 1.705 mm {0.06713 in} = 3.3358 mm {0.13133 in}, the selected snap ring has a thickness of 1.8 mm {0.071 in}.

8. Assemble the selected snap ring to the position shown in the figure.

Caution

- Assemble so that the end gap of the snap ring is positioned diagonally opposed to the end gap of the snap ring for the high clutch.
- After assembling the snap ring, verify that the snap ring is securely inserted into the bottom of the snap ring groove.

Note

- Snap ring size: Outer diameter approx. 169.3 mm {6.665 in}

A : Snap ring (low clutch)

B : Snap ring (high clutch)

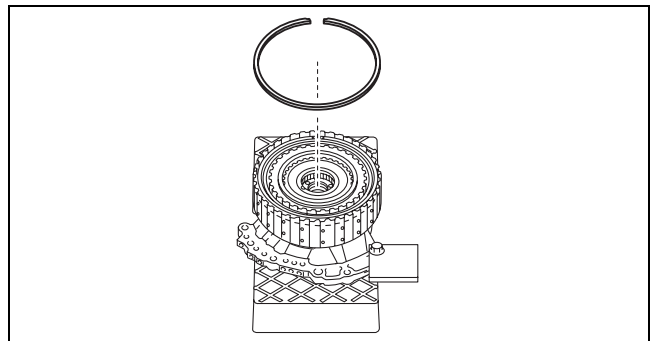

azzjiw00001098

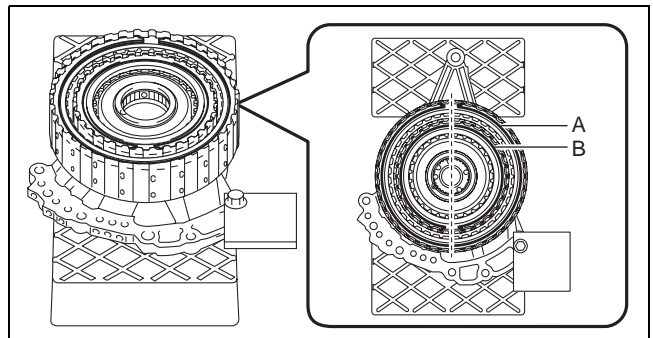

azzjiw00001099

AUTOMATIC TRANSAXLE

9. Install the SST.

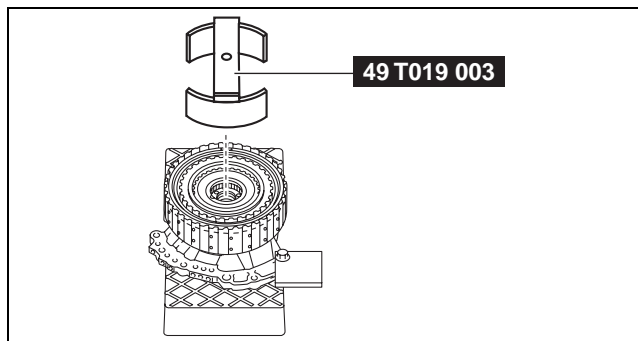

azzjjw00001097

05-17

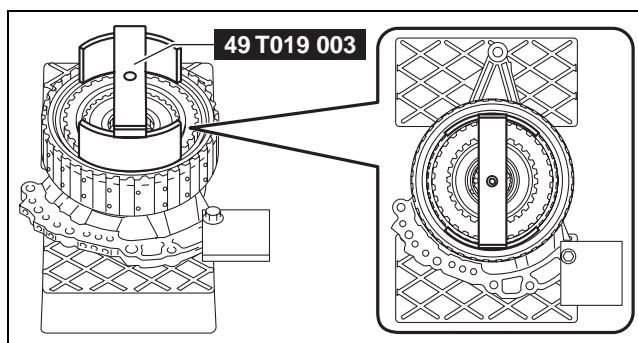

azzjjw00001100

10. Place a 98—196 N {10.0—19.9 kgf, 23.0—44.0 lbf} weight on the SST using the following procedure:

Note

- Use a V-block as a weight.

- (1) Measure the weight of the weight placed on the SST.
- (2) Input the measured weight into the measurement/adjustment value input sheet.
- (3) Place the measured weight on the SST.

A : Weight (V-block)

Caution

- To reduce error during the low clutch clearance measurement, place the weight near the center of the SST.

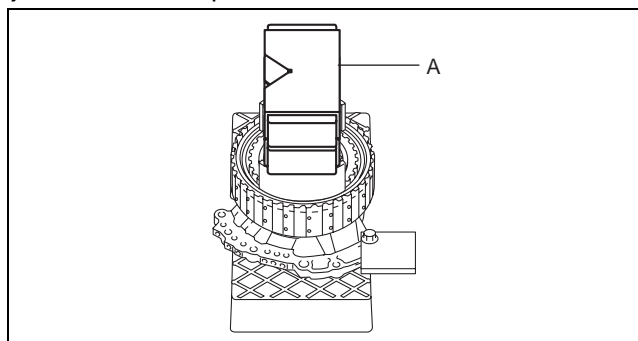

azzjjw00001101

AUTOMATIC TRANSAXLE

11. Perform the following calculation to calculate the correction value for the low clutch clearance.

Note

- Because a wave spring is included in the low clutch, a correction value is required for the low clutch clearance according to the weight of the weight used during the low clutch clearance measurement.

Correction value of low clutch clearance (weight of unit is N) = (A - 90 N) × 0.00157 mm {0.0000618 in}

A: Weight of weight

Note

Example

A: Weight of weight is 150 N

Correction value of low clutch clearance = (150 N - 90 N) × 0.00157 mm {0.0000618 in} = 0.0942 mm {0.00371 in}

Correction value of low clutch clearance (weight of unit is kgf) = (A - 9.18 kgf) × 0.01540 mm {0.0006063 in}

A: Weight of weight

Note

Example

A: Weight of weight is 15.30 kgf

Correction value of low clutch clearance = (15.30 kgf - 9.18 kgf) × 0.01540 mm {0.0006063 in} = 0.0942 mm {0.00371 in}

Correction value of low clutch clearance (weight of unit is lbf) = (A - 20.23 lbf) × 0.00698 mm {0.0002748 in}

A: Weight of weight

Note

Example

A: Weight of weight is 33.72 lbf

Correction value of low clutch clearance = (33.72 lbf - 20.23 lbf) × 0.00698 mm {0.0002748 in} = 0.0942 mm {0.00371 in}

12. Perform the low clutch clearance measurement from Step 9 (2). (See 05-17-327 Low Clutch Clearance Measurement.)

R-3-5 BRAKE CLEARANCE MEASUREMENT/ADJUSTMENT

id051700664900

Preparation Before Servicing

1. Print out the measurement/adjustment value input sheet. (See 05-17-295 MEASUREMENT/ADJUSTMENT VALUE INPUT SHEET.)

Note

- When performing the measurement/adjustment, input the measured and calculated values into the measurement/adjustment value input sheet.
- When performing the other measurements/adjustments, if the measurement/adjustment value input sheet has been printed out, use the printed sheet.

05-17

R-3-5 Brake Clearance Measurement/Adjustment

1. Measure the retainer thickness of the springs and retainer component.

Note

- Recommended measuring instrument: Micrometer
- Springs and retainer component size: Inner diameter approx. 148.8 mm {5.858 in}

2. Input the measured retainer thickness of the springs and retainer component into the measurement/adjustment value input sheet.

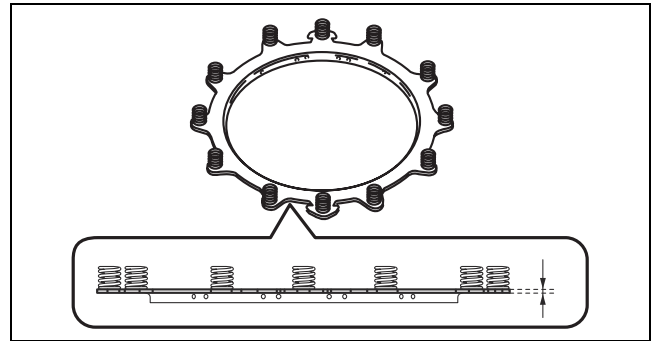

azzjjw00001199

3. Assemble the drive plates and driven plates.

- A : Drive plate
B : Driven plate

Note

- Drive plate size: Outer diameter approx. 169.4 mm {6.669 in}
- Driven plate size: Inner diameter approx. 141.8 mm {5.583 in}

Assembly order

Driven plate—drive plate—driven plate—drive plate—driven plate—drive plate

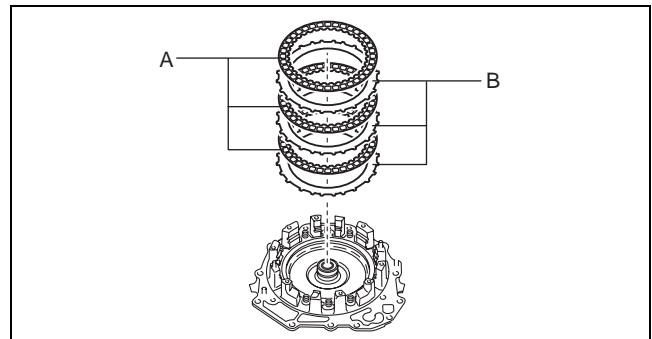

azzjjw00001179

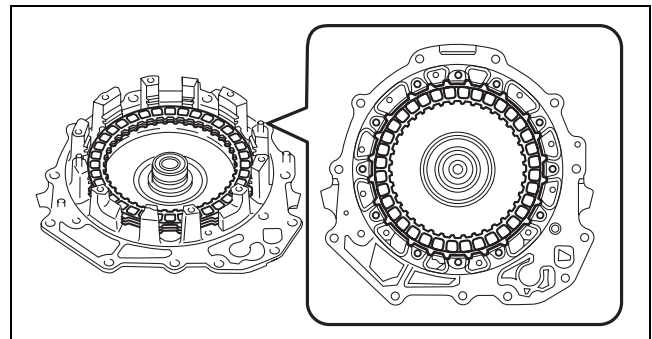

azzjjw00001180

AUTOMATIC TRANSAXLE

4. Assemble the retaining plate.

Note

- Retaining plate size: Inner diameter approx. 141.8 mm {5.583 in}

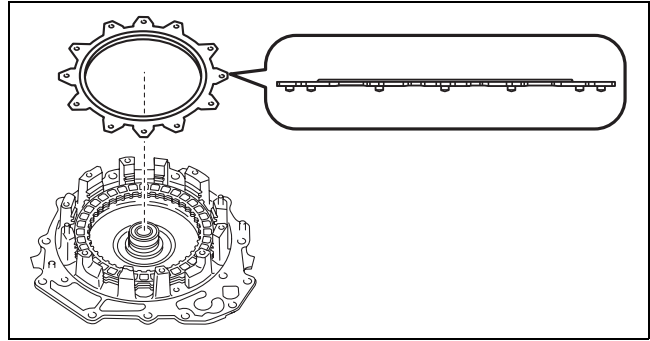

azzjw00001181

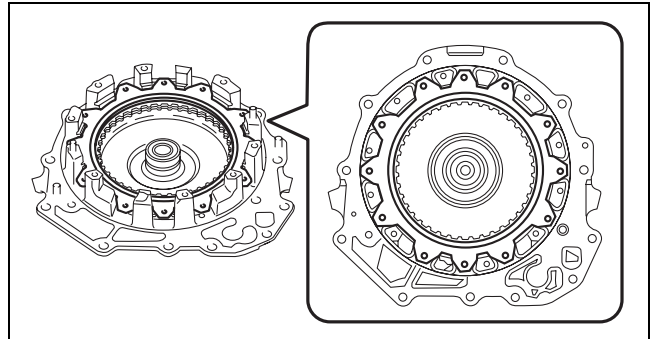

azzjw00001182

5. Assemble the snap ring (FZ01 19 469) for the R-3-5 brake clearance measurement/adjustment to the position shown in the figure.

Caution

- Assemble the snap ring so that the end gap of the snap ring is in the area shown in the figure.
- After assembling the snap ring, verify that the snap ring is securely inserted into the bottom of the snap ring groove.

Note

- Snap ring size: Outer diameter approx. 186.2 mm {7.331 in}

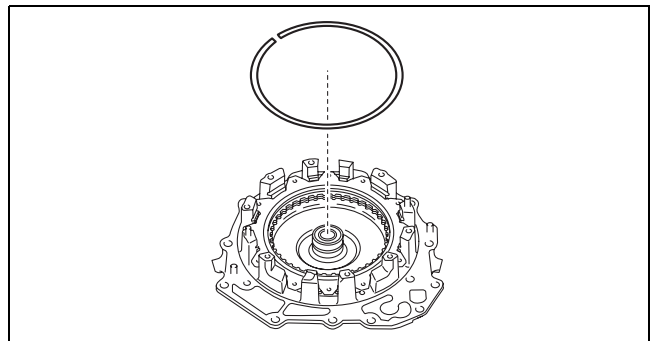

azzjw00001183

A : End gap of snap ring assembly area

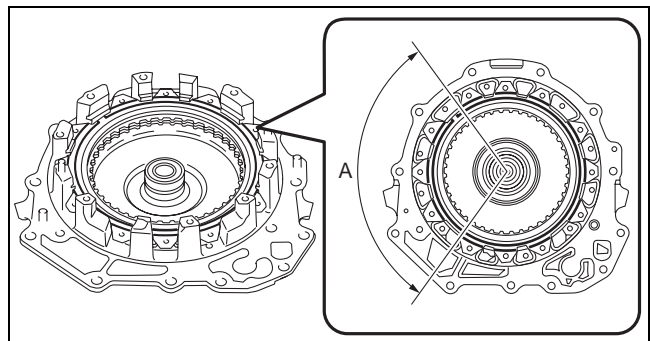

azzjw00001184

AUTOMATIC TRANSAXLE

6. Set the end cover for the assembled part on the workbench as shown in the figure.

A : Rubber plate

Caution

- To reduce error during the R-3-5 brake clearance adjustment value measurement, use the rubber plates to adjust the alignment surface of the end cover with the transaxle case so that it is level.

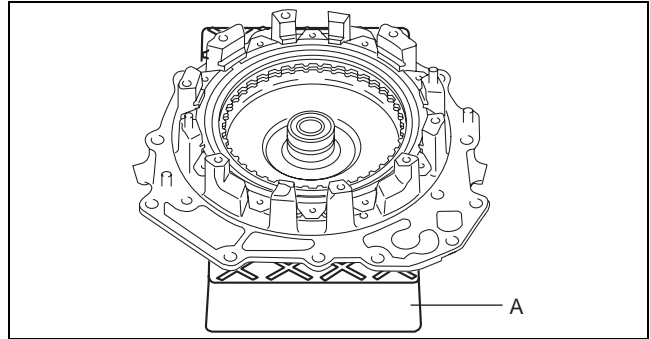

azzjw00001185

05-17

7. Install the SST.

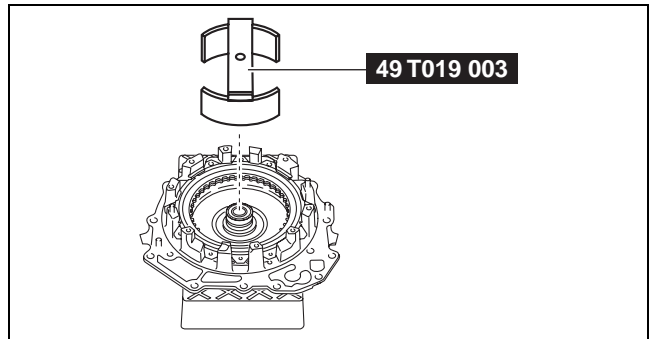

azzjw00001186

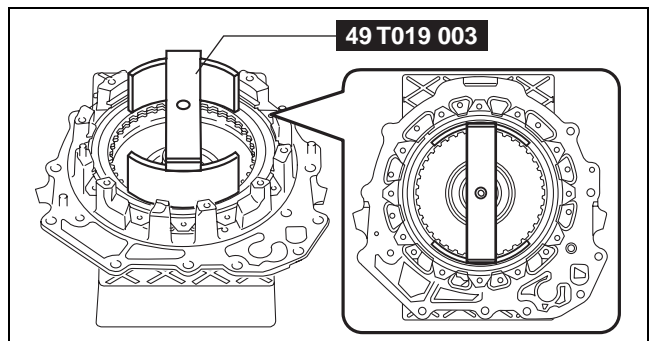

azzjw00001187

8. Place a 98—196 N {10.0—19.9 kgf, 23.0—44.0 lbf} weight on the SST.

A : Weight (V-block)

Caution

- To reduce error during the R-3-5 brake clearance adjustment value measurement, place the weight near the center of the SST.

Note

- Use a V-block as a weight.

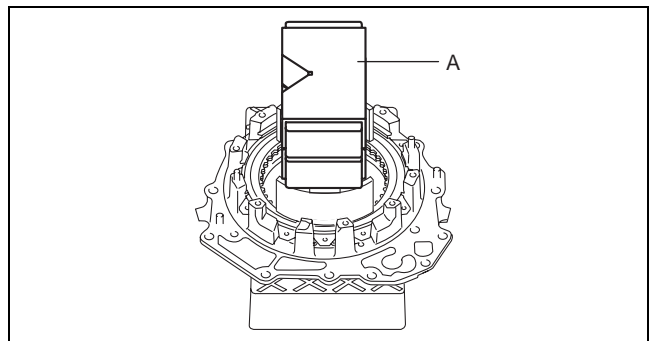

azzjw00001188

AUTOMATIC TRANSAXLE

9. Set the measuring instrument to the end cover using the following procedure.

- (1) Install an appropriate steel plate for securing the magnetic stand used in the procedure shown in the figure..

1	Steel plate (for securing magnetic stand)
2	Bolt (M8)
3	Nut (M8)

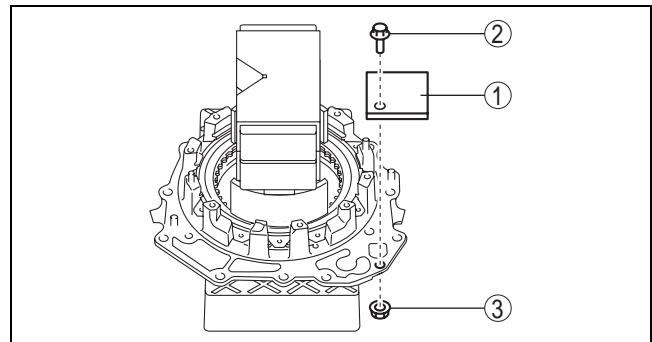

Caution

- If the bolt and nut are tightened with excessive force when installing the steel plate, the alignment surface of the end cover with the transaxle case could be damaged. Tighten the bolt and nut so that the steel plate does not move during the R-3-5 brake clearance adjustment value measurement.

Note

- When installing the steel plate to the end cover, use an M8 bolt and nut.

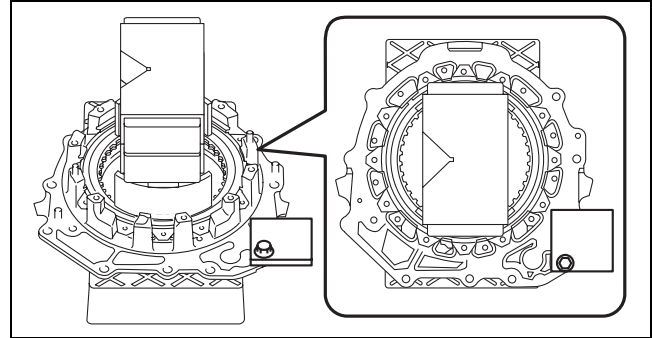

Steel plate installation bolt tightening torque
15 N·m {1.5 kgf·m, 11 ft·lbf} or less (tighten so that steel plate does not move during R-3-5 brake clearance adjustment value measurement)

- (2) Set the dial gauge and magnetic stand as shown in the figure.

A : Dial gauge
 B : Magnetic stand

Caution

- To reduce error during the R-3-5 brake clearance adjustment value measurement, set the dial gauge so that it is perpendicular to alignment surface of the end cover with the transaxle case.

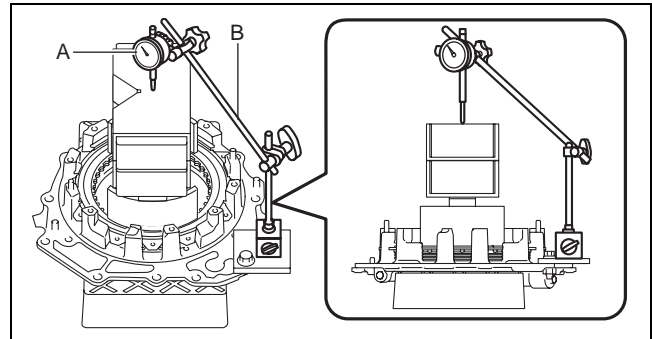

- (3) Set the dial gauge end near the center of the weight.

A : Area in which dial gauge end is set

Caution

- To reduce error during the R-3-5 brake clearance adjustment value measurement, set the dial gauge end to within the area shown in the figure.

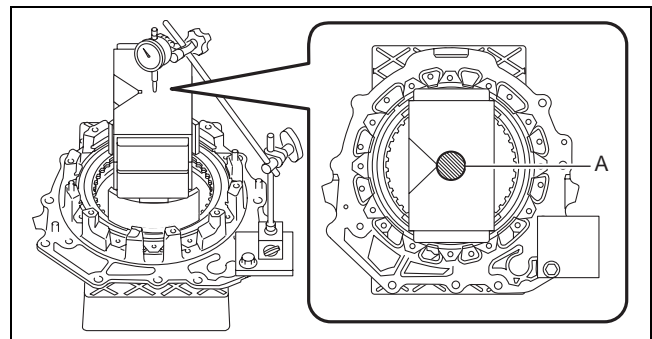

AUTOMATIC TRANSAXLE

10. Measure the R-3-5 brake clearance adjustment value using the following procedure:

- (1) Blow compressed air into the oil passage shown in the figure and verify the operation condition of the R-3-5 brake piston (approx. 3 times).

Warning

- Always wear protective eye wear when using the air compressor. Otherwise, ATF or dirt particles blown off by the air compressor could get into the eyes.

Caution

- To prevent damage to parts, always use an air compressor which is adjusted to the indicated pressure.

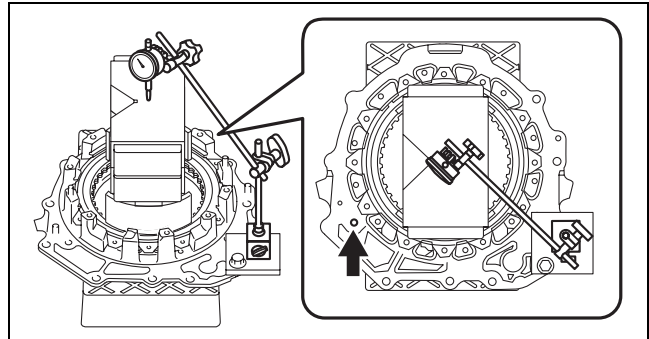

azzjjw00001193

05-17

Compressed air pressure

0.39—0.44 MPa {4.0—4.4 kgf/cm², 57—63 psi}

- (2) Blow compressed air into the oil passage shown in the figure and operate the R-3-5 brake piston to read the value when the dial gauge is stabilized.

Warning

- Always wear protective eye wear when using the air compressor. Otherwise, ATF or dirt particles blown off by the air compressor could get into the eyes.

Caution

- To prevent damage to parts, always use an air compressor which is adjusted to the indicated pressure.

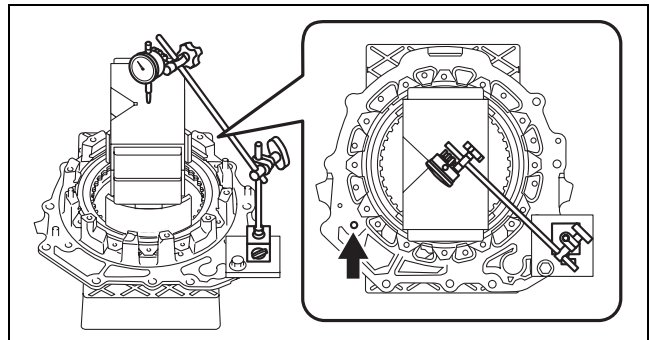

azzjjw00001193

Compressed air pressure

0.39—0.44 MPa {4.0—4.4 kgf/cm², 57—63 psi}

- (3) Input the dial gauge value, which was read while the R-3-5 brake piston was operating, into the measurement/adjustment value input sheet.
- (4) Release the compressed air and read the dial gauge value without the R-3-5 brake piston operating.
- (5) Input the dial gauge value, which was read without the R-3-5 brake piston operating, into the measurement/adjustment value input sheet.
- (6) Perform the following calculation to calculate the R-3-5 brake clearance adjustment value.

R-3-5 brake clearance adjustment value = B - C

B: Dial gauge value with R-3-5 brake piston operated

C: Dial gauge value without R-3-5 brake piston operated

Note

Example

B: Dial gauge value with R-3-5 brake piston operating is 2.280 mm {0.08976 in}

C: Dial gauge value without R-3-5 brake piston operated is 0.205 mm {0.00807 in}

R-3-5 brake clearance adjustment value = 2.280 mm {0.08976 in} - 0.205 mm {0.00807 in} = 2.075 mm {0.08169 in}

- (7) Input the calculated R-3-5 brake clearance adjustment value into the measurement/adjustment value input sheet.

AUTOMATIC TRANSAXLE

11. Remove the dial gauge and magnetic stand.

- A : Dial gauge
- B : Magnetic stand

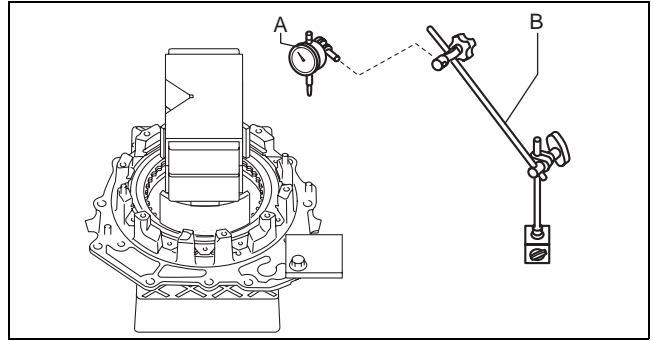

azzjiw00001194

12. Remove the steel plate for securing the magnetic stand using the procedure shown in the figure.

1	Nut (M8)
2	Bolt (M8)
3	Steel plate (for securing magnetic stand)

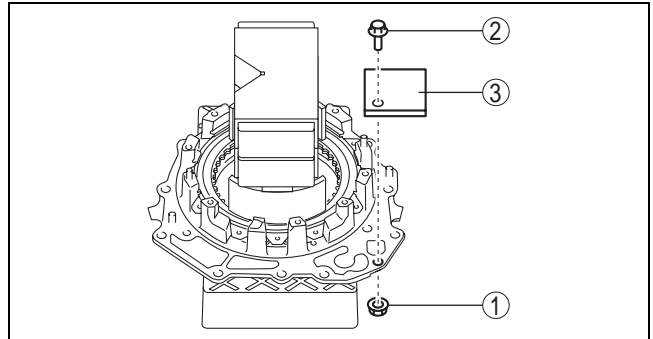

azzjiw00001195

13. Remove the weight on the SST.

- A : Weight (V-block)

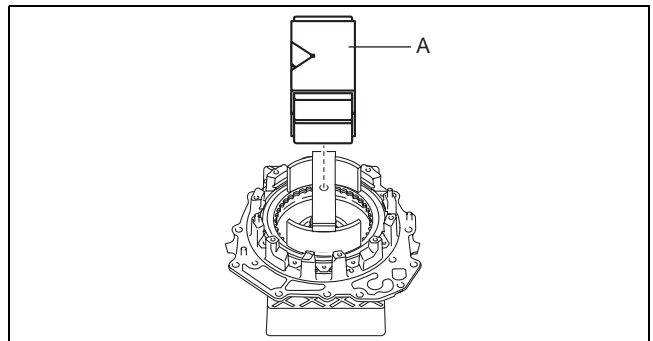

azzjiw00001196

14. Remove the SST.

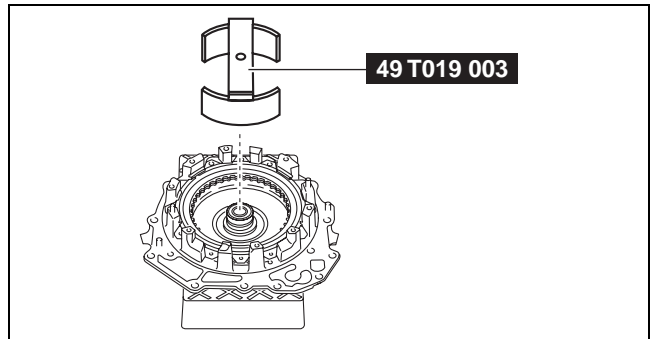

azzjiw00001186

AUTOMATIC TRANSAXLE

15. Take the end cover off the rubber plates.

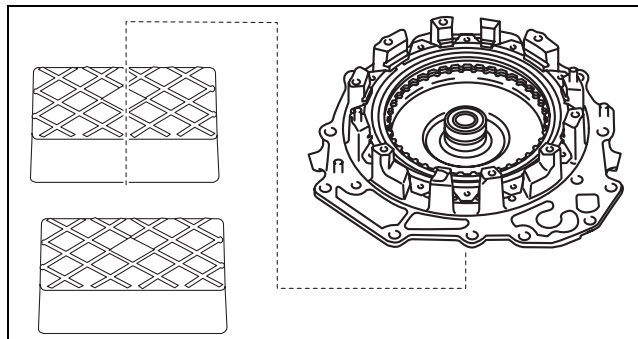

azzjw00001197

16. Remove the snap ring (FZ01 19 469) for the R-3-5 brake clearance measurement/adjustment.

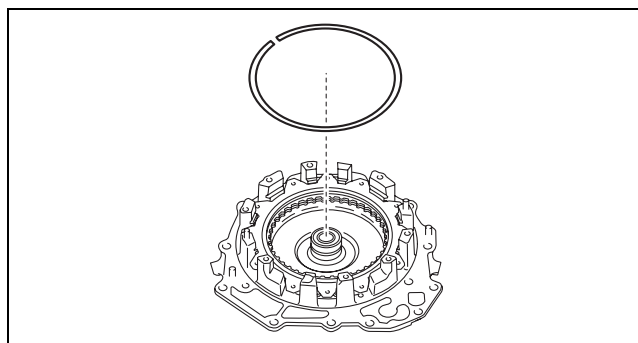

azzjw00001183

17. Measure the thickness of the removed snap ring (FZ01 19 469) for the R-3-5 brake clearance measurement/adjustment.

Note

- Recommended measuring instrument: Micrometer

18. Input the measured snap ring (FZ01 19 469) thickness for the R-3-5 brake clearance measurement/adjustment into the measurement/adjustment value input sheet.

05-17

AUTOMATIC TRANSAXLE

19. Select the appropriate snap ring from the following table:

Range*	Selected snap ring thickness
Exceeds 3.830 mm {0.1508 in}, 3.930 mm {0.1547 in} or less	2.6 mm {0.102 in}
Exceeds 3.730 mm {0.1469 in}, 3.830 mm {0.1508 in} or less	2.5 mm {0.098 in}
Exceeds 3.630 mm {0.1429 in}, 3.730 mm {0.1469 in} or less	2.4 mm {0.094 in}
Exceeds 3.530 mm {0.1390 in}, 3.630 mm {0.1429 in} or less	2.3 mm {0.091 in}
Exceeds 3.430 mm {0.1350 in}, 3.530 mm {0.1390 in} or less	2.2 mm {0.087 in}
Exceeds 3.330 mm {0.1311 in}, 3.430 mm {0.1350 in} or less	2.1 mm {0.083 in}
Exceeds 3.230 mm {0.1272 in}, 3.330 mm {0.1311 in} or less	2.0 mm {0.079 in}
Exceeds 3.130 mm {0.1232 in}, 3.230 mm {0.1272 in} or less	1.9 mm {0.075 in}
Exceeds 3.030 mm {0.1193 in}, 3.130 mm {0.1232 in} or less	1.8 mm {0.071 in}
Exceeds 2.930 mm {0.1154 in}, 3.030 mm {0.1193 in} or less	1.7 mm {0.067 in}

* : The range is the thickness of the removed snap ring (FZ01 19 469) used for the R-3-5 brake clearance measurement/adjustment added to the R-3-5 brake clearance adjustment value, from which the retainer thickness of the springs and retainer component is subtracted.

Range = D + E - A

A: Retainer thickness of springs and retainer component

D: R-3-5 brake clearance adjustment value

E: Thickness of snap ring (FZ01 19 469) for R-3-5 brake clearance measurement/adjustment

Note

Example

A: Retainer thickness of springs and retainer component is 1.225 mm {0.04823 in}

D: R-3-5 brake clearance adjustment value is 2.075 mm {0.08169 in}

E: Thickness of snap ring (FZ01 19 469) for R-3-5 brake clearance measurement/adjustment is 2.625 mm {0.10335 in}

Range = 2.075 mm {0.08169 in} + 2.625 mm {0.10335 in} - 1.225 mm {0.04823 in} = 3.475 mm {0.13681 in}, the selected snap ring has a thickness of 2.2 mm {0.087 in}.

20. Remove the retaining plate.

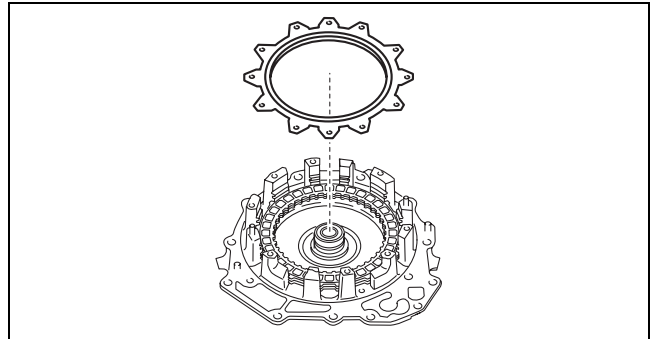

azzjiw00001198

21. Remove the drive plates and driven plates.

A : Drive plate

B : Driven plate

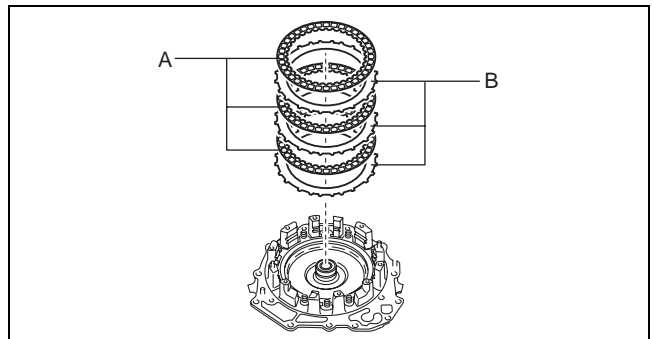

azzjiw00001179

2-6 BRAKE CLEARANCE MEASUREMENT/ADJUSTMENT

id051700664800

Preparation Before Servicing

1. Print out the measurement/adjustment value input sheet. (See 05-17-295 MEASUREMENT/ADJUSTMENT VALUE INPUT SHEET.)

Note

- When performing the measurement/adjustment, input the measured and calculated values into the measurement/adjustment value input sheet.
- When performing the other measurements/adjustments, if the measurement/adjustment value input sheet has been printed out, use the printed sheet.

05-17

2-6 Brake Clearance Measurement

1. Set the end cover for the assembled part on the workbench as shown in the figure.

A : Rubber plate

Caution

- To reduce error during the 2-6 brake clearance measurement, use the rubber plates to adjust the alignment surface of the end cover with the transaxle case so that it is level.

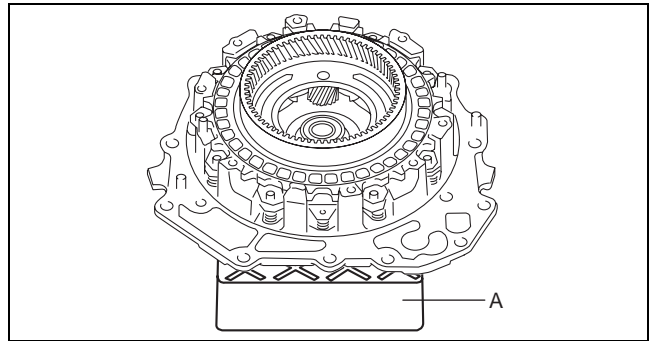

azzjjw00001168

2. Measure the retainer thickness of the springs and retainer component.

Note

- Recommended measuring instrument: Micrometer
- Springs and retainer component size: Inner diameter approx. 150.6 mm {5.929 in}

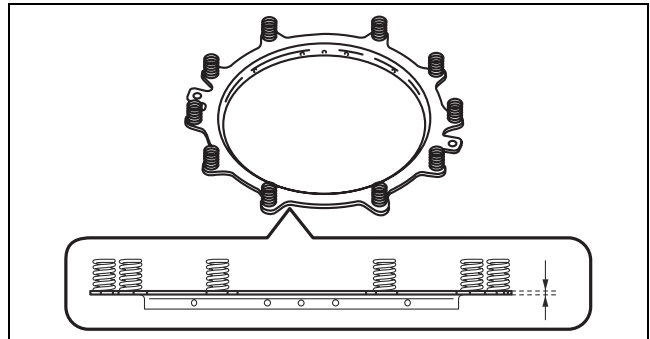

azzjjw00001169

3. Input the measured retainer thickness of the springs and retainer component into the measurement/adjustment value input sheet.

AUTOMATIC TRANSAXLE

4. Assemble the retaining plate.

Note

- Retaining plate size: Inner diameter approx. 148 mm {5.83 in}

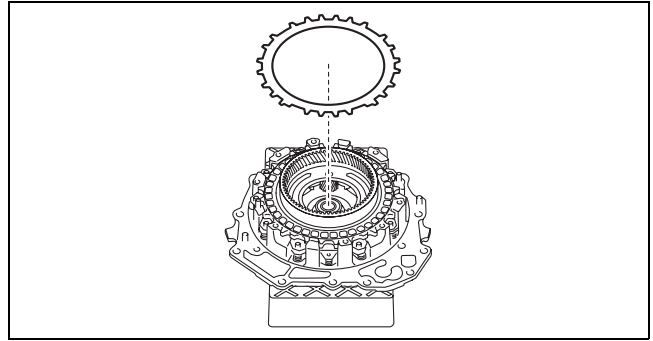

azzjiw00001170

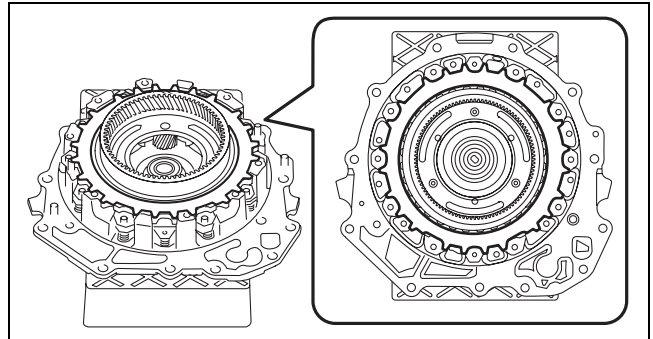

azzjiw00001171

5. Install the SST.

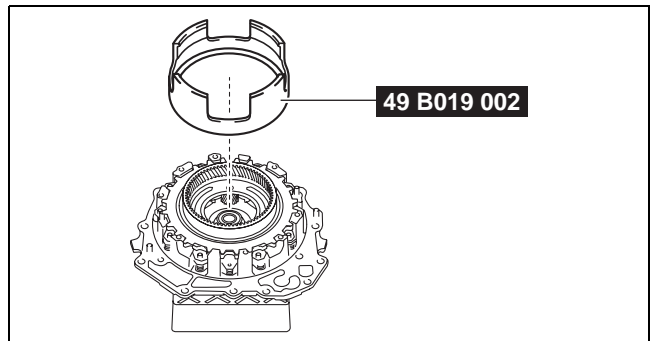

azzjiw00001172

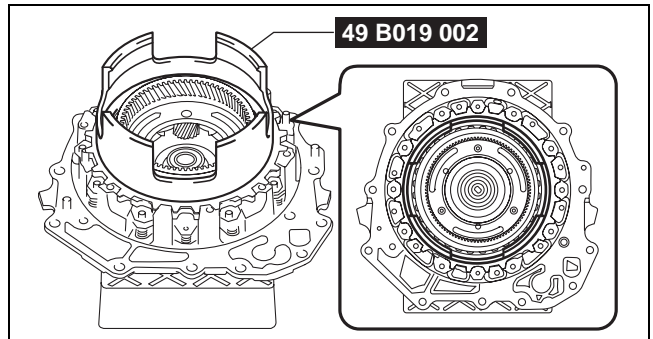

azzjiw00001173

AUTOMATIC TRANSAXLE

6. Place a 98—196 N {10.0—19.9 kgf, 23.0—44.0 lbf} weight on the SST.

A : Weight (V-block)

Caution

- To reduce error during the 2-6 brake clearance measurement, place the weight near the center of the SST.

Note

- Use a V-block as a weight.

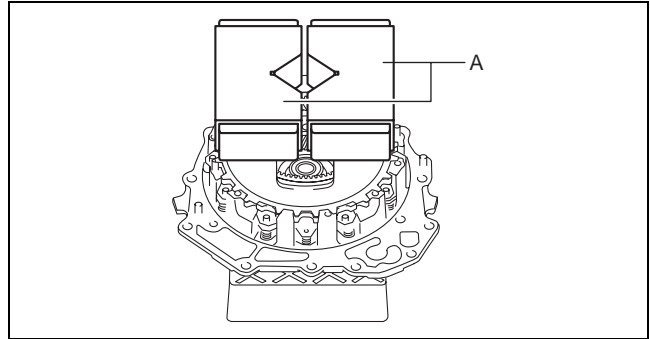

azzijw00001174

7. Measure distance A shown in the figure in four locations (each separated by 90°) and calculate the average value of distance A.

A : Distance A

B : End cover end (alignment surface with brake housing)

C : Retaining plate end

Note

- Recommended measuring instrument: Depth micrometer
- Measure the splines of the retaining plate using a depth micrometer.

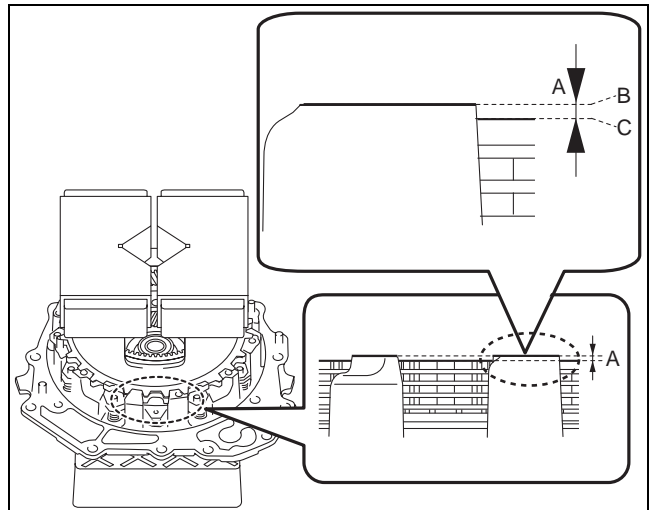

azzijw00001575

8. Input the measured distance A and calculated distance A average value into the measurement/adjustment value input sheet.

9. Perform the following calculation to calculate the 2-6 brake clearance.

2-6 brake clearance = C - A

A: Retainer thickness of springs and retainer component

C: Average value of distance A

Note

Example

A: Retainer thickness of springs and retainer component is 1.425 mm {0.05610 in}

C: Average value of distance A is 2.665 mm {0.10492 in}

2-6 brake clearance = 2.665 mm {0.10492 in} - 1.425 mm {0.05610 in} = 1.240 mm {0.04882 in}

10. Input the calculated 2-6 brake clearance into the measurement/adjustment value input sheet.

11. Verify that the 2-6 brake clearance satisfies the specification.

Specification

1.000—1.200 mm {0.03938—0.04724 in}

- If not within the specification, adjust the 2-6 brake clearance. (See 05-17-351 2-6 Brake Clearance Adjustment.)

AUTOMATIC TRANSAXLE

12. Remove the weight on the SST.

A : Weight (V-block)

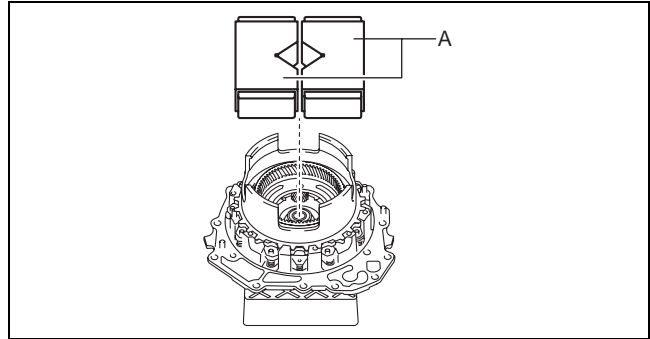

azzjw00001176

13. Remove the SST.

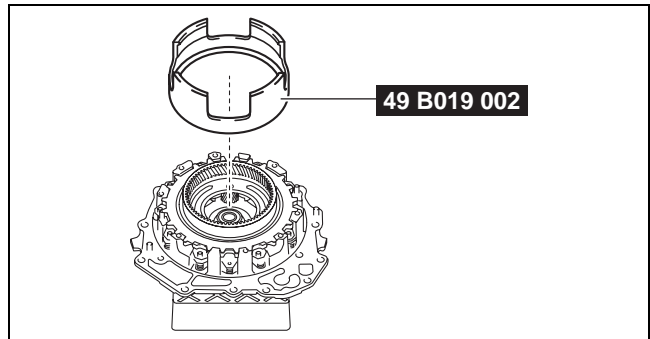

azzjw00001172

14. Take the end cover off the rubber plates.

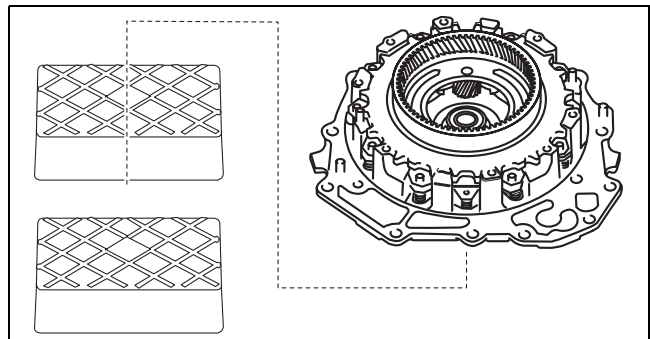

azzjw00001177

AUTOMATIC TRANSAXLE

2-6 Brake Clearance Adjustment

1. Remove the weight on the SST.

A : Weight (V-block)

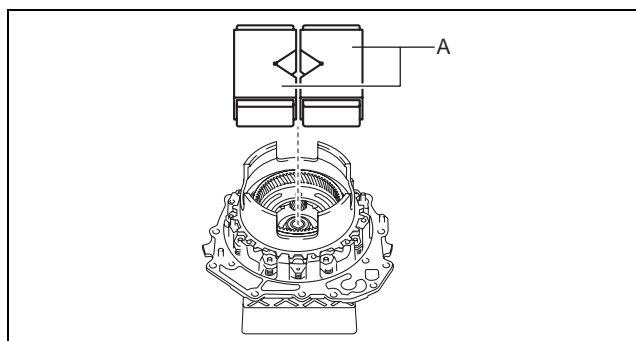

azzjjw00001176

2. Remove the SST.

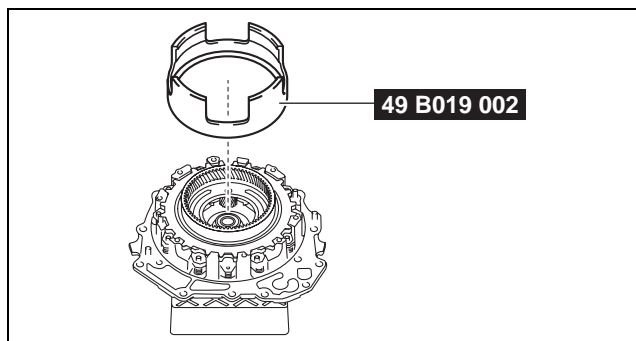

azzjjw00001172

3. Remove the retaining plate.

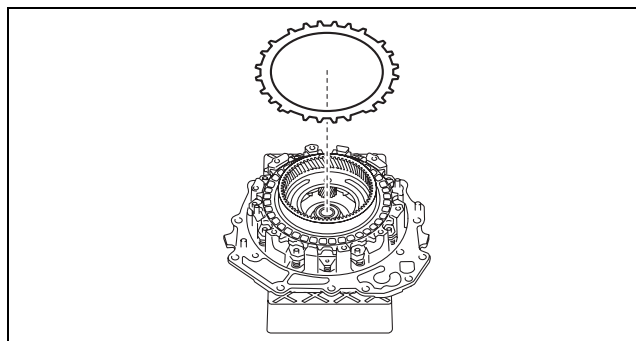

azzjjw00001170

4. Measure the thickness of the removed retaining plate.

Note

- Recommended measuring instrument: Micrometer

5. Input the measured retaining plate thickness into the measurement/adjustment value input sheet.

05-17

AUTOMATIC TRANSAXLE

6. Select the appropriate retaining plate from the following table:

Range*	Selected retaining plate thickness
Exceeds 3.550 mm {0.1398 in}, 3.650 mm {0.1437 in} or less	2.5 mm {0.098 in}
Exceeds 3.450 mm {0.1358 in}, 3.550 mm {0.1398 in} or less	2.4 mm {0.094 in}
Exceeds 3.350 mm {0.1319 in}, 3.450 mm {0.1358 in} or less	2.3 mm {0.091 in}
Exceeds 3.250 mm {0.1280 in}, 3.350 mm {0.1319 in} or less	2.2 mm {0.087 in}
Exceeds 3.150 mm {0.1240 in}, 3.250 mm {0.1280 in} or less	2.1 mm {0.083 in}
Exceeds 3.050 mm {0.1201 in}, 3.150 mm {0.1240 in} or less	2.0 mm {0.079 in}
Exceeds 2.950 mm {0.1161 in}, 3.050 mm {0.1201 in} or less	1.9 mm {0.075 in}
Exceeds 2.850 mm {0.1122 in}, 2.950 mm {0.1161 in} or less	1.8 mm {0.071 in}
Exceeds 2.750 mm {0.1083 in}, 2.850 mm {0.1122 in} or less	1.7 mm {0.067 in}

* : The range is the sum of the 2-6 brake clearance and the thickness value of the removed retaining plate.

Range = D + G

D: 2-6 brake clearance

G: Thickness of removed retaining plate

Note

Example

D: 2-6 brake clearance is 1.240 mm {0.04882 in}

G: Thickness of removed retaining plate is 2.015 mm {0.07933 in}

Range = 1.240 mm {0.04882 in} + 2.015 mm {0.07933 in} = 3.255 mm {0.12815 in}, the selected retaining plate has a thickness of 2.2 mm {0.087 in}.

7. Assemble the selected retaining plate.

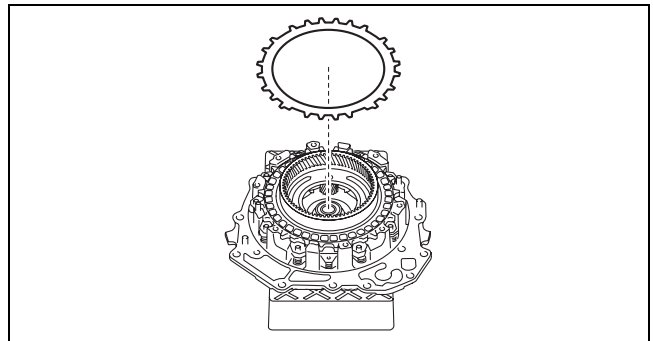

azzjiw00001170

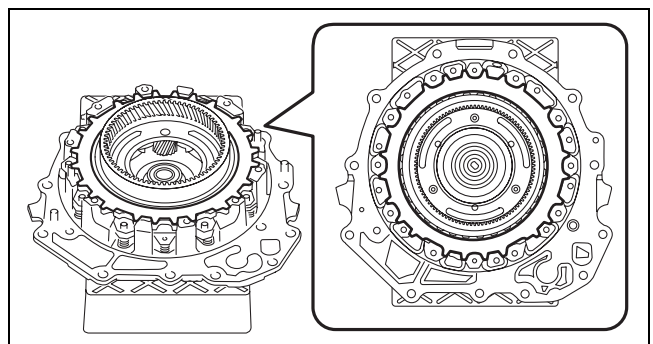

azzjiw00001171

8. Perform the 2-6 brake clearance measurement from Step 5. (See 05-17-347 2-6 Brake Clearance Measurement.)

AUTOMATIC TRANSAXLE

LOW AND REVERSE BRAKE CLEARANCE MEASUREMENT/ADJUSTMENT

id051700664700

Preparation Before Servicing

1. Print out the measurement/adjustment value input sheet. (See 05-17-295 MEASUREMENT/ADJUSTMENT VALUE INPUT SHEET.)

Note

- When performing the measurement/adjustment, input the measured and calculated values into the measurement/adjustment value input sheet.
- When performing the other measurements/adjustments, if the measurement/adjustment value input sheet has been printed out, use the printed sheet.

05-17

Low and Reverse Brake Clearance Measurement

1. Rotate and adjust the rotation handle of the engine stand so that the end cover side is facing upward.

Caution

- To reduce error during the low and reverse brake clearance measurement, adjust so that the alignment surface of the transaxle case with the end cover is level.

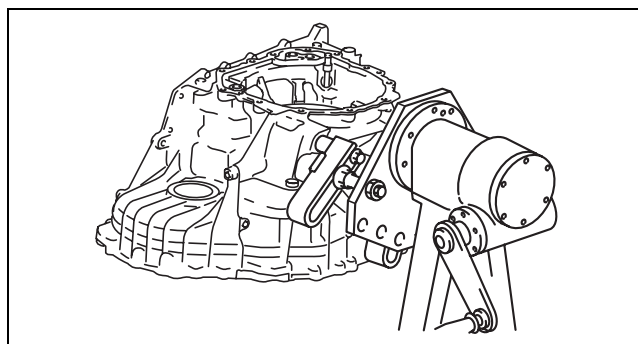

azzjjw00000734

AUTOMATIC TRANSAXLE

2. Assemble the snap ring using the following procedure:

Note

- Snap ring size: Outer diameter approx. 198.0 mm {7.795 in}

(1) Install the SSTs.

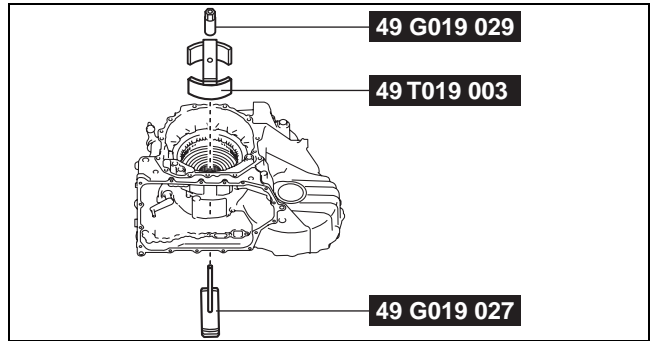

azzjw00000735

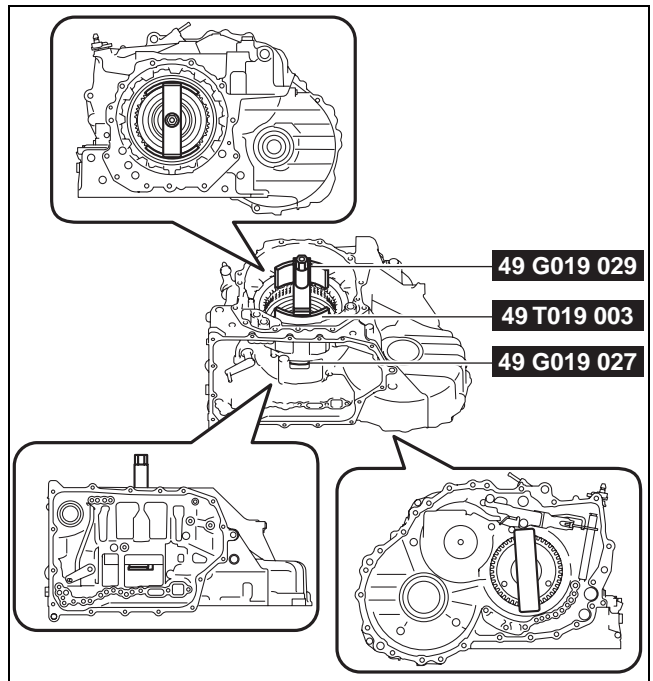

azzjw00000736

(2) Tighten the SST (49 G019 029) until the snap ring groove of the transaxle case comes out.

A : Snap ring groove

Caution

- If the SST (49 G019 029) is tightened with excessive force, surrounding parts could be damaged. Stop tightening the SST when the snap ring groove of the transaxle case comes out.

Note

- Lock the SST (49 G019 027) against rotation using a flathead screwdriver and tighten the SST (49 G019 029).

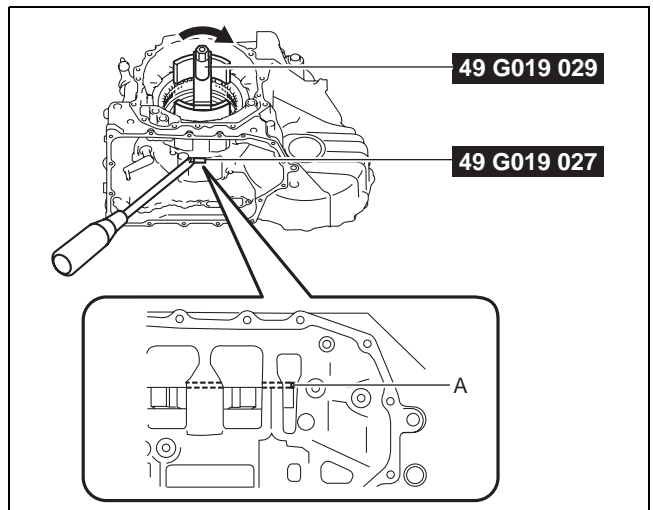

azzjw00000737

AUTOMATIC TRANSAXLE

- (3) Assemble the snap ring to the position shown in the figure.

Caution

- Assemble the snap ring so that the end gap of the snap ring is in the area shown in the figure.
- After assembling the snap ring, verify that the snap ring is securely inserted into the bottom of the snap ring groove.

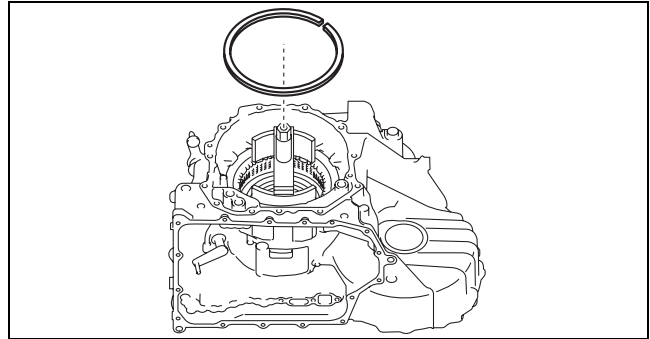

azzjjw00000738

05-17

A : End gap of snap ring assembly area

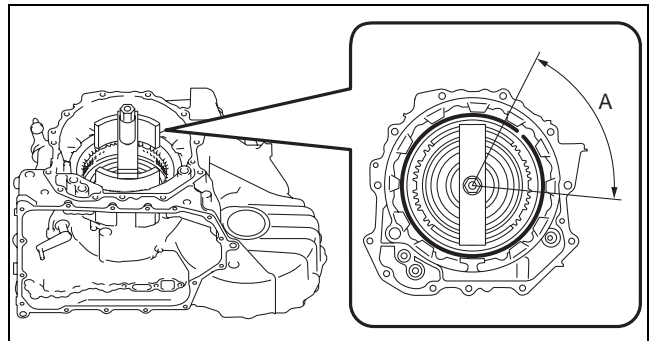

azzjjw00000739

- (4) Loosen the SST (49 G019 029) and remove the SSTs.

Note

- Lock the SST (49 G019 027) against rotation using a flathead screwdriver and loosen the SST (49 G019 029).

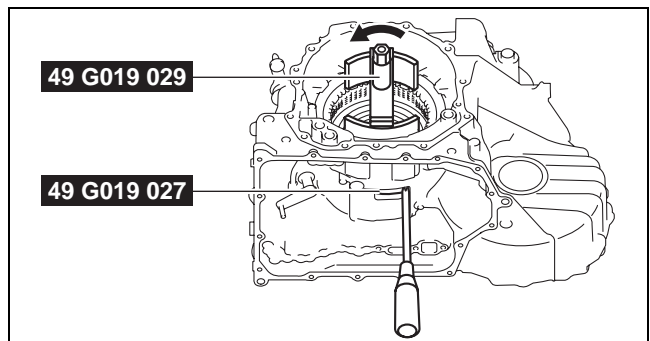

azzjjw00000740

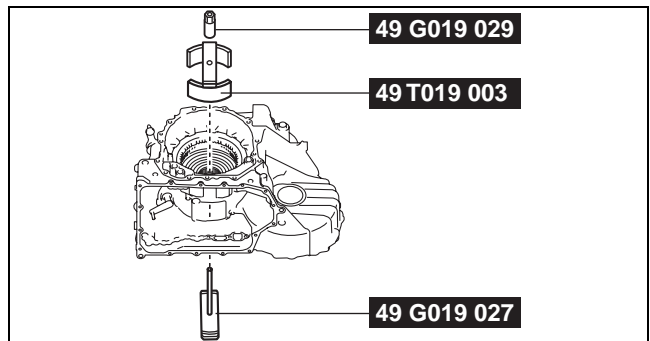

azzjjw00000735

AUTOMATIC TRANSAXLE

3. Set the measuring instrument to the transaxle case using the following procedure.
 - (1) Install the steel plate for securing the magnetic stand using the procedure shown in the figure.

Caution

- If the bolt is tightened with excessive force when installing the steel plate, the alignment surface of the end cover with the transaxle case could be damaged. Tighten the bolt so that the steel plate does not move during low and reverse brake clearance measurement.
- To prevent damage to the parts, the bolt holes in the transaxle case which are used for securing the steel plate are the penetrated bolt holes shown in the figure.

Note

- When installing the steel plate to the transaxle case, use a bolt (M8×1.25).
- Use a bolt length in which the bolt end comes out of the transaxle case bolt hole but does not contact the transaxle case.
- Because it is necessary to measure the low and reverse brake clearance in four locations (each separated by 90°), change the steel plate installation position to the area of the bolt installation position shown in the figure then install the steel plate to a position which facilitates measurement.

A : Bolt installation position for steel plate installation

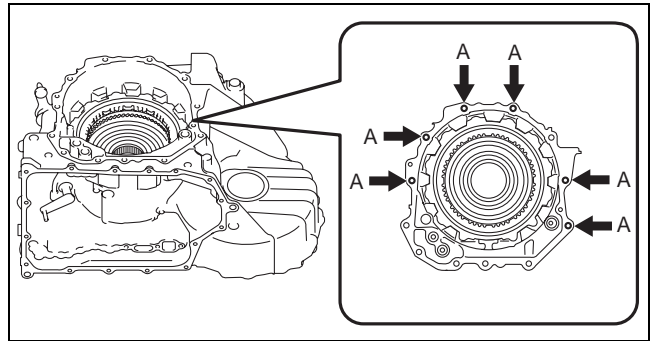

azzjiw00000741

1	Steel plate (for securing magnetic stand)
2	Bolt (M8×1.25)*

* : Use a bolt length in which the bolt end comes out of the transaxle case bolt hole but does not contact the transaxle case.

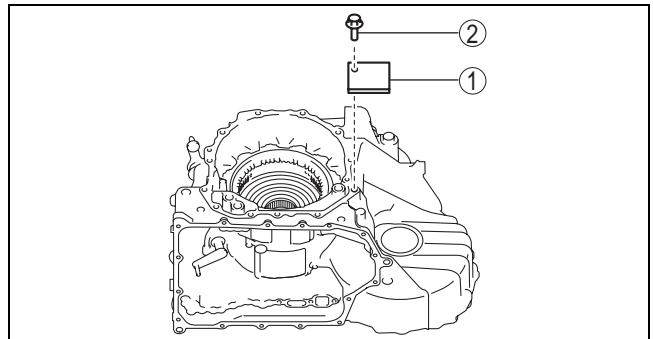

azzjiw00000742

**Steel plate installation bolt tightening torque
15 N·m {1.5 kgf·m, 11 ft·lbf} or less (tighten
so that steel plate does not move during
low and reverse brake clearance
measurement)**

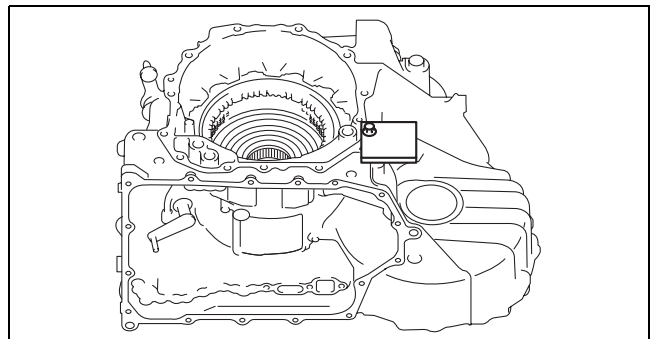

azzjiw00000743

AUTOMATIC TRANSAXLE

(2) Set the dial gauge and magnetic stand as shown in the figure.

A : Dial gauge
B : Magnetic stand

Caution

- To reduce error during the low and reverse brake clearance measurement, set the dial gauge so that it is perpendicular to the alignment surface of the transaxle case with the end cover.

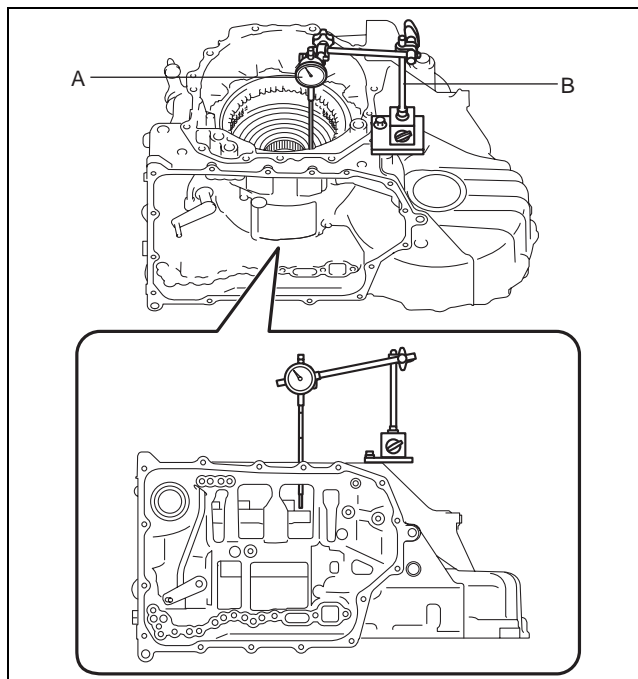

azzijw00000744

(3) Set the dial gauge end to the low and reverse brake piston.

A : Area in which dial gauge end is set

Note

- Measure the stroke amount of the low and reverse brake piston as the low and reverse brake clearance.

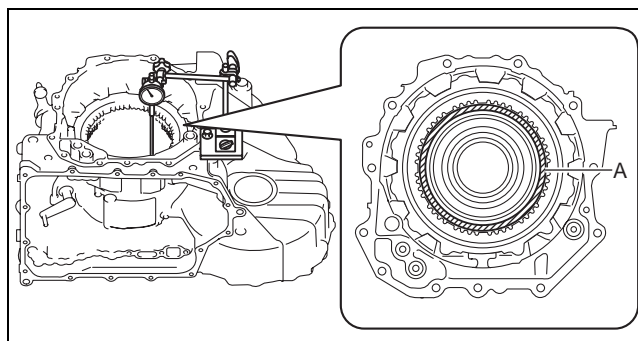

azzijw00000745

AUTOMATIC TRANSAXLE

4. Measure the low and reverse brake clearance using the following procedure:

- (1) Blow compressed air into the oil passage shown in the figure and verify the operation condition of the low and reverse brake (approx. 3 times).

Warning

- Always wear protective eye wear when using the air compressor. Otherwise, ATF or dirt particles blown off by the air compressor could get into the eyes.

Caution

- To prevent damage to parts, always use an air compressor which is adjusted to the indicated pressure.

Compressed air pressure

0.39—0.44 MPa {4.0—4.4 kgf/cm²,
57—63 psi}

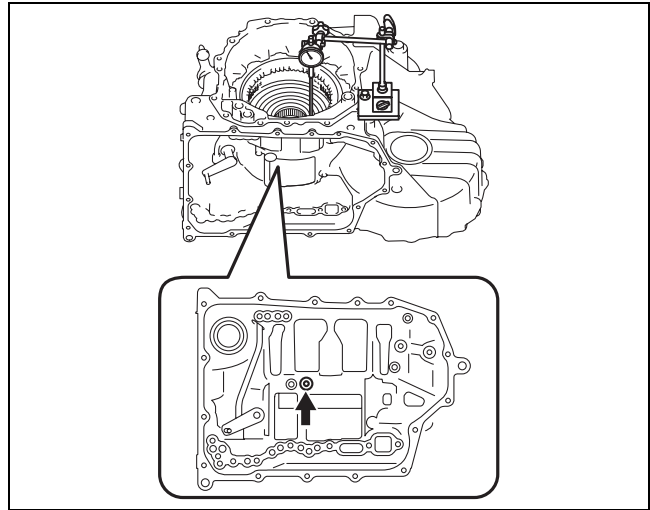

azzjiw00000746

- (2) Blow compressed air into the oil passage shown in the figure and operate the low and reverse brake piston to read the value when the dial gauge is stabilized.

Warning

- Always wear protective eye wear when using the air compressor. Otherwise, ATF or dirt particles blown off by the air compressor could get into the eyes.

Caution

- To prevent damage to parts, always use an air compressor which is adjusted to the indicated pressure.

Compressed air pressure

0.39—0.44 MPa {4.0—4.4 kgf/cm²,
57—63 psi}

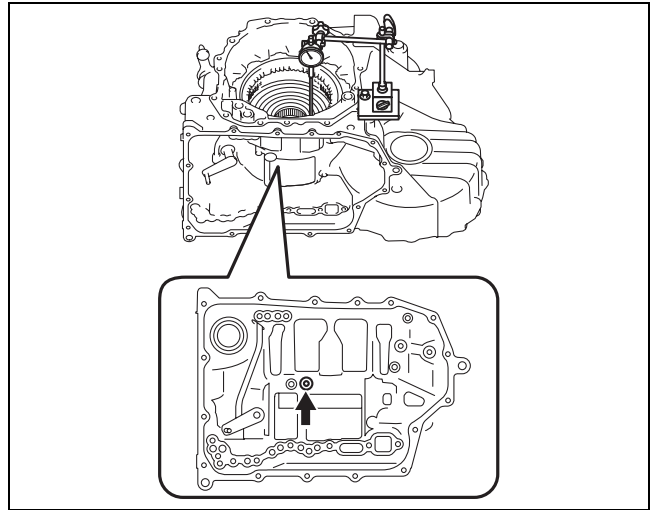

azzjiw00000746

- (3) Input the dial gauge value, which was read while the low and reverse brake piston was operating, into the measurement/adjustment value input sheet.
- (4) Release the compressed air and read the dial gauge value without the low and reverse brake piston operating.
- (5) Input the dial gauge value, which was read without the low and reverse brake piston operating, into the measurement/adjustment value sheet.
- (6) Perform the following calculation to calculate the low and reverse brake clearance.

Low and reverse brake clearance = A – B

A: Dial gauge value with low and reverse brake piston operating

B: Dial gauge value without low and reverse brake piston operating

Note

Example

A: Dial gauge value with low and reverse brake piston operating is 2.470 mm {0.09724 in}

B: Dial gauge value without low and reverse brake piston operating is 0.595 mm {0.02343 in}

Low and reverse brake clearance = 2.470 mm {0.09724 in} – 0.595 mm {0.02343 in} = 1.875 mm {0.07382 in}

- (7) Input the calculated low and reverse brake clearance into the measurement/adjustment value sheet.

AUTOMATIC TRANSAXLE

(8) Measure the low and reverse brake clearance in four locations (each separated by 90°) and calculate the average value of the low and reverse brake clearance.

Note

- Change the set positions of the dial gauge and magnetic stand and measure the low and reverse brake clearance in four locations (each separated by 90°).

(9) Input the average value of the calculated low and reverse brake clearance into the measurement/adjustment value sheet.

(10) Verify that the average value of the low and reverse brake clearance satisfies the specification.

05-17

Specification

1.650—1.850 mm {0.06497—0.07283 in}

- If not within the specification, adjust the low and reverse brake clearance. (See 05-17-360 Low and Reverse Brake Clearance Adjustment.)

5. Remove the dial gauge and magnetic stand.

A : Dial gauge
B : Magnetic stand

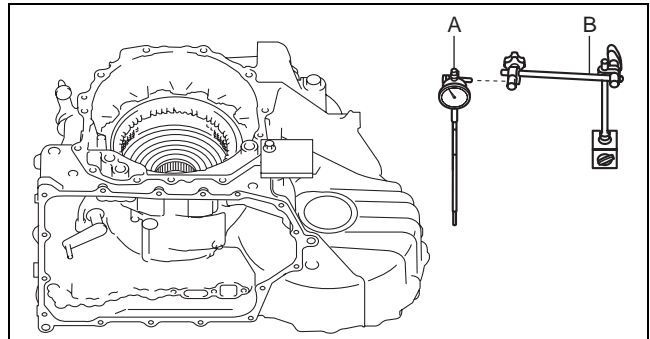

azzjw00000747

6. Remove the steel plate for securing the magnetic stand using the procedure shown in the figure.

1	Bolt
2	Steel plate (for securing magnetic stand)

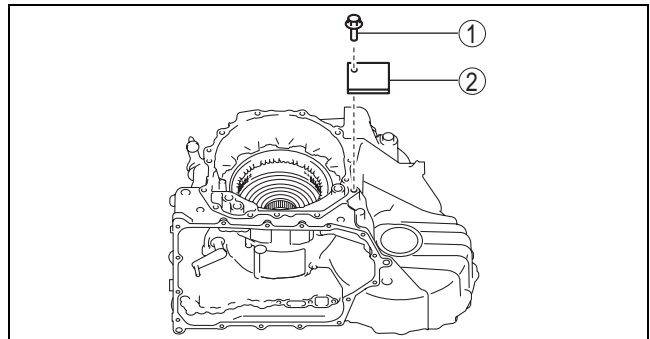

azzjw00000748

AUTOMATIC TRANSAXLE

Low and Reverse Brake Clearance Adjustment

1. Remove the dial gauge and magnetic stand.

- A : Dial gauge
- B : Magnetic stand

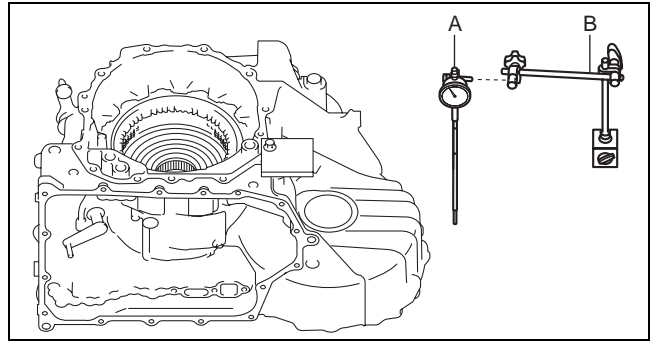

azzjiw00000747

2. Remove the steel plate for securing the magnetic stand using the procedure shown in the figure.

1	Bolt
2	Steel plate (for securing magnetic stand)

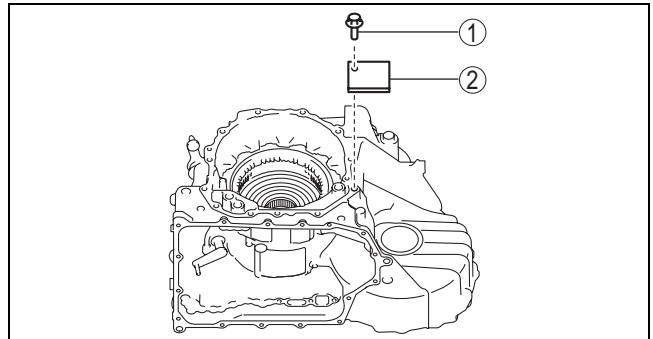

azzjiw00000748

3. Remove the snap ring using the following procedure:
(1) Install the SSTs.

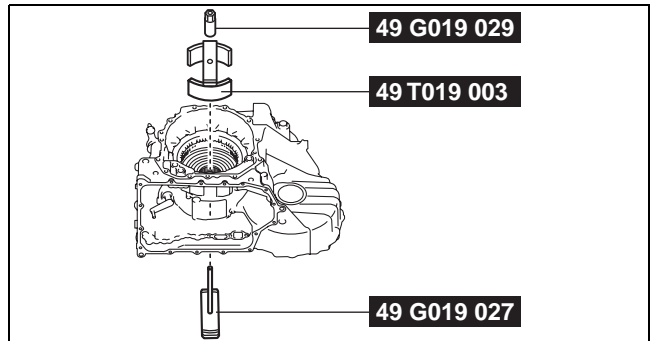

azzjiw00000735

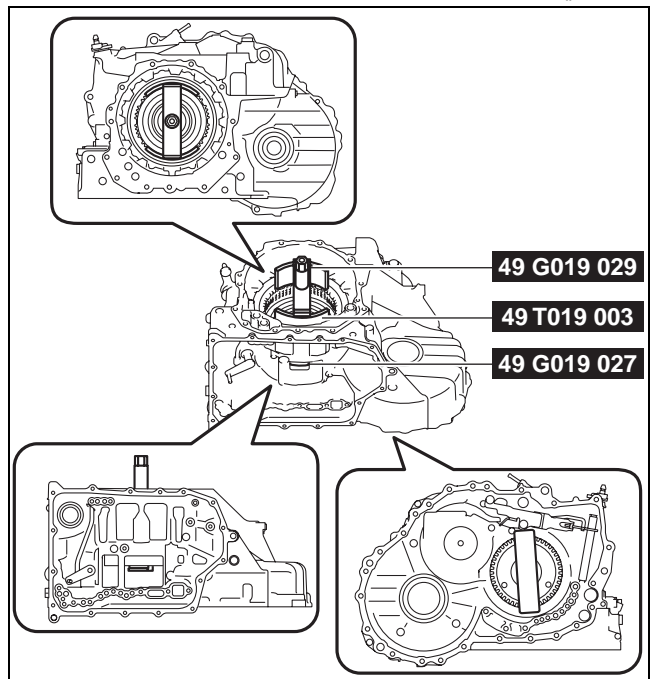

azzjiw00000736

AUTOMATIC TRANSAXLE

- (2) Tighten the SST (49 G019 029) until there is no longer any spring force from the springs and retainer component applied to the snap ring.

A : Snap ring
B : One-way clutch
C : Gap

Caution

- If the SST (49 G019 029) is tightened with excessive force, surrounding parts could be damaged. Stop tightening if a gap appears between the snap ring and one-way clutch

Note

- Lock the SST (49 G019 027) against rotation using a flathead screwdriver and tighten the SST (49 G019 029).

- (3) Remove the snap ring.

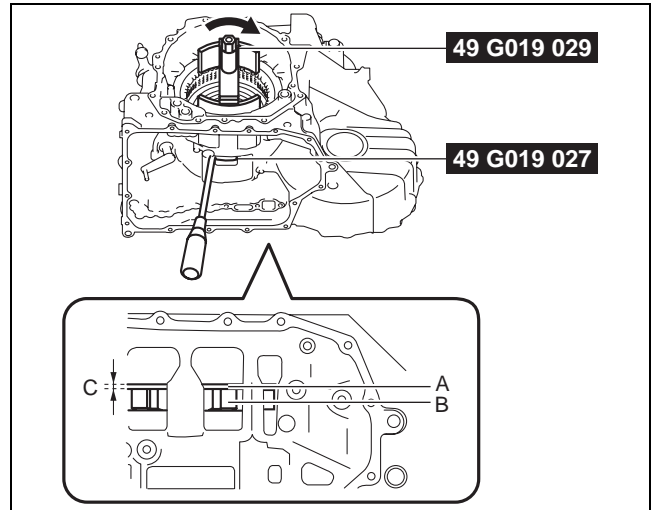

azzjjw00000749

05-17

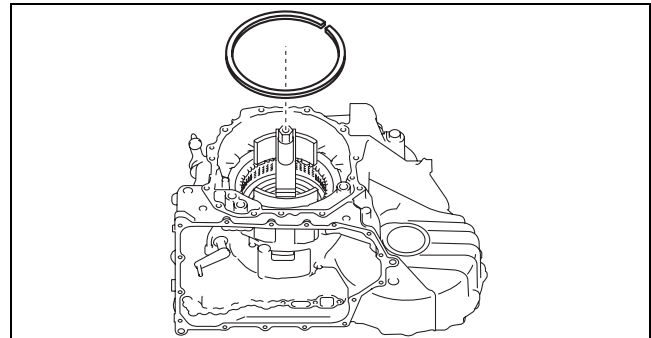

azzjjw00000738

4. Measure the thickness of the removed snap ring.

Note

- Recommended measuring instrument: Micrometer

5. Input the measured snap ring thickness into the measurement/adjustment value input sheet.

AUTOMATIC TRANSAXLE

6. Select the appropriate snap ring from the following table:

Range*	Selected snap ring thickness
Exceeds 4.500 mm {0.1772 in}, 4.600 mm {0.1811 in} or less	2.8 mm {0.110 in}
Exceeds 4.400 mm {0.1732 in}, 4.500 mm {0.1772 in} or less	2.7 mm {0.106 in}
Exceeds 4.300 mm {0.1693 in}, 4.400 mm {0.1732 in} or less	2.6 mm {0.102 in}
Exceeds 4.200 mm {0.1654 in}, 4.300 mm {0.1693 in} or less	2.5 mm {0.098 in}
Exceeds 4.100 mm {0.1614 in}, 4.200 mm {0.1654 in} or less	2.4 mm {0.094 in}
Exceeds 4.000 mm {0.1575 in}, 4.100 mm {0.1614 in} or less	2.3 mm {0.091 in}
Exceeds 3.900 mm {0.1535 in}, 4.000 mm {0.1575 in} or less	2.2 mm {0.087 in}
Exceeds 3.800 mm {0.1496 in}, 3.900 mm {0.1535 in} or less	2.1 mm {0.083 in}
Exceeds 3.700 mm {0.1457 in}, 3.800 mm {0.1496 in} or less	2.0 mm {0.079 in}
Exceeds 3.600 mm {0.1417 in}, 3.700 mm {0.1457 in} or less	1.9 mm {0.075 in}
Exceeds 3.500 mm {0.1378 in}, 3.600 mm {0.1417 in} or less	1.8 mm {0.071 in}

* : The range is the sum of the average value of the low and reverse brake clearance and the thickness value of the removed snap ring.

Range = D + G

D: Average value of low and reverse brake clearance

G: Thickness of removed snap ring

Note

Example

D: Average value of low and reverse brake clearance is 1.879 mm {0.07398 in}

G: Thickness of removed snap ring is 2.305 mm {0.09075 in}

Range = 1.879 mm {0.07398 in} + 2.305 mm {0.09075 in} = 4.184 mm {0.16472 in}, the selected snap ring has a thickness of 2.4 mm {0.094 in}.

7. Assemble the selected snap ring using the following procedure:

Note

- Snap ring size: Outer diameter approx. 198.0 mm {7.795 in}

(1) Tighten the SST (49 G019 029) until the snap ring groove of the transaxle case comes out.

A : Snap ring groove

Caution

- If the SST (49 G019 029) is tightened with excessive force, surrounding parts could be damaged. Stop tightening the SST when the snap ring groove of the transaxle case comes out.

Note

- Lock the SST (49 G019 027) against rotation using a flathead screwdriver and tighten the SST (49 G019 029).

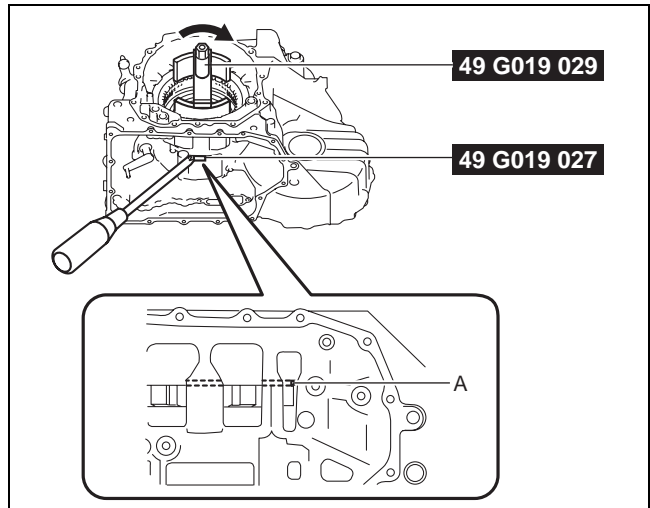

azzjiw00000737

AUTOMATIC TRANSAXLE

- (2) Assemble the snap ring to the position shown in the figure.

Caution

- Assemble the snap ring so that the end gap of the snap ring is in the area shown in the figure.
- After assembling the snap ring, verify that the snap ring is securely inserted into the bottom of the snap ring groove.

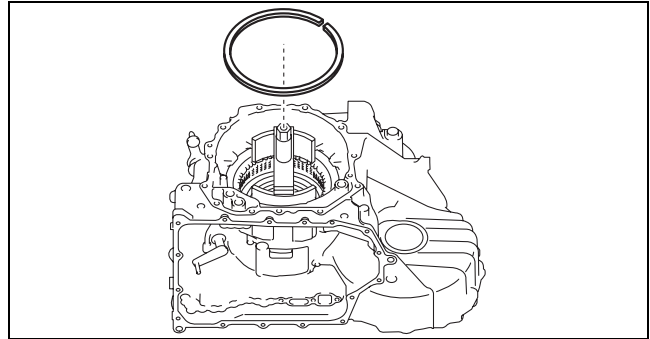

azzjw00000738

05-17

A : End gap of snap ring assembly area

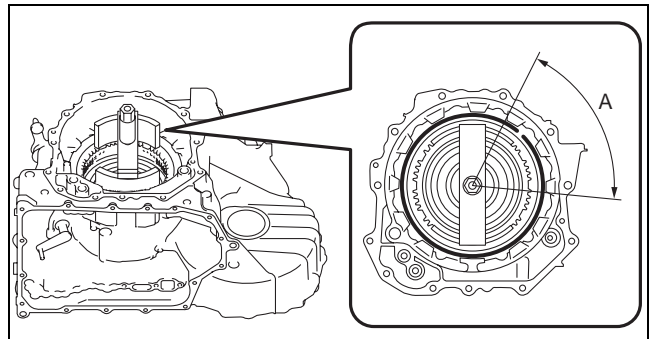

azzjw00000739

- (3) Loosen the SST (49 G019 029) and remove the SSTs.

Note

- Lock the SST (49 G019 027) against rotation using a flathead screwdriver and loosen the SST (49 G019 029).

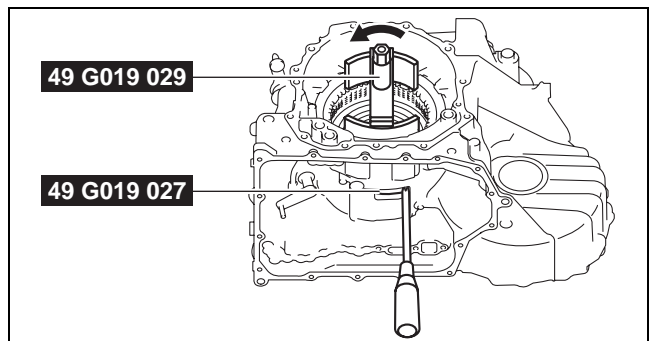

azzjw00000740

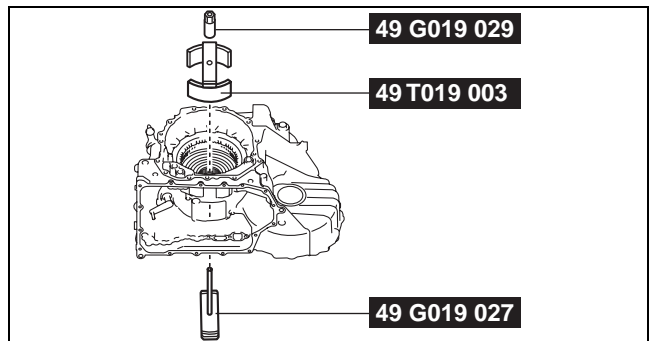

azzjw00000735

8. Perform the low and reverse brake clearance measurement from Step 3. (See 05-17-353 Low and Reverse Brake Clearance Measurement.)

AUTOMATIC TRANSAXLE

SECONDARY GEAR AND OUTPUT GEAR PRELOAD MEASUREMENT/ADJUSTMENT

id051700665000

Preparation Before Servicing

1. Print out the measurement/adjustment value input sheet. (See 05-17-295 MEASUREMENT/ADJUSTMENT VALUE INPUT SHEET.)

Note

- When performing the measurement/adjustment, input the measured and calculated values into the measurement/adjustment value input sheet.
- When performing the other measurements/adjustments, if the measurement/adjustment value input sheet has been printed out, use the printed sheet.

Secondary Gear and Output Gear Preload Measurement

1. Rotate and adjust the rotation handle of the engine stand so that the converter housing side is facing upward.

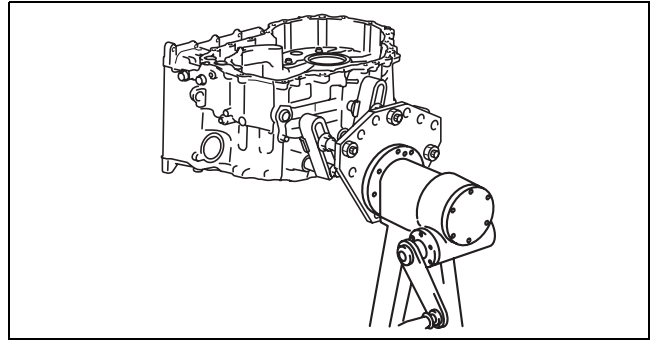

azzjw00000750

2. Rotate the parking shift lever component to the N position as shown in the figure.

- A : Parking shift lever component
B : Manual plate component
C : Detent bracket component

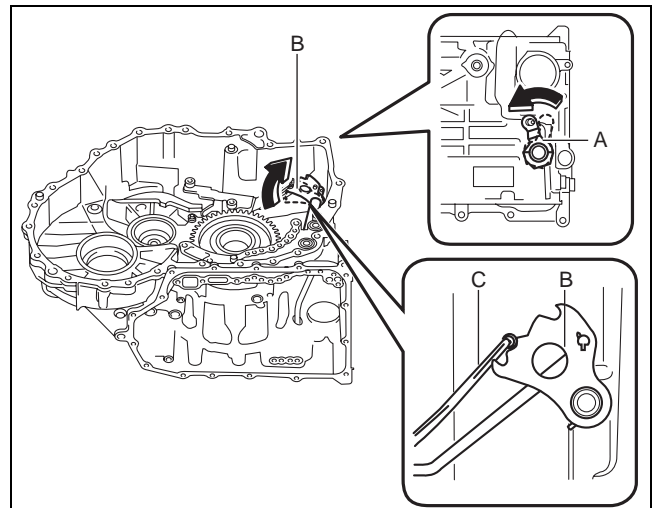

azzjw00000751

3. Remove any remaining old sealant on the contact surfaces of the transaxle case and converter housing.

AUTOMATIC TRANSAXLE

4. Measure the angular contact ball bearing preload using the following procedure:

(1) Set the SSTs, extension bar, and torque wrench as shown in the figure.

- A : Extension bar
- B : Torque wrench
- C : Bolt supplied with SST (49 B019 029) or M8×1.25, length to 18 mm {0.71 in}

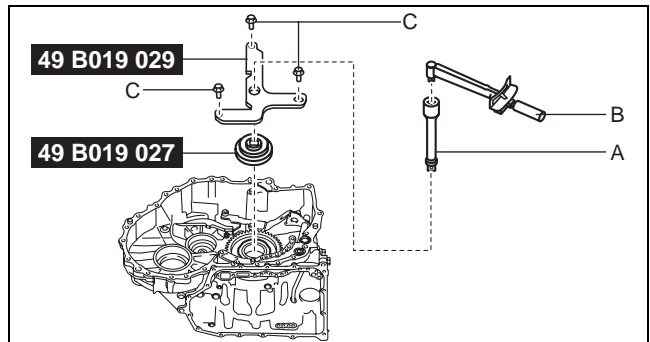

azzjjw00001577

- A : Extension bar
- B : Torque wrench
- C : Bolt supplied with SST (49 B019 029) or M8×1.25, length to 18 mm {0.71 in}

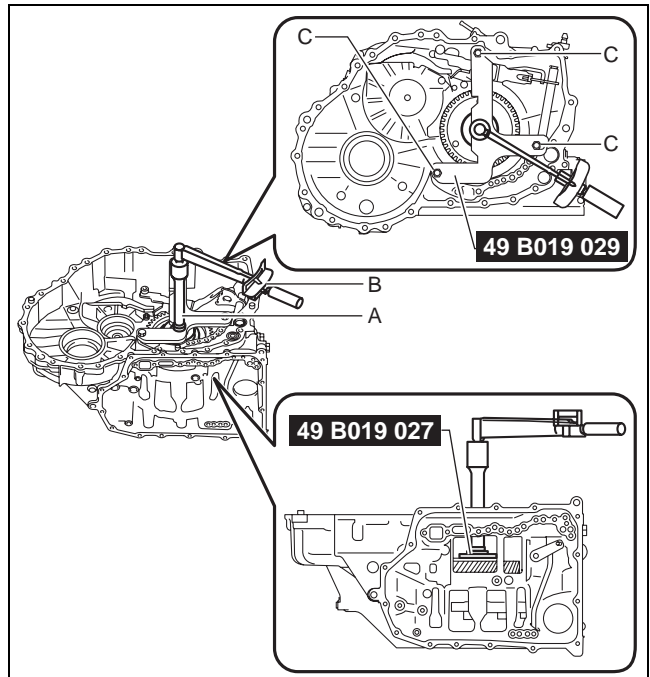

azzjjw00001609

(2) Rotate the locknut (primary gear) in the direction of the arrow shown in the figure using a torque wrench and measure the angular contact ball bearing preload.

Caution

- After rotating the locknut (primary gear) approx. 10 times in the direction of the arrow shown in the figure, measure the angular contact ball bearing preload to engage the angular contact ball bearing.
- When the locknut (primary gear) is rotated at approx. 20 rpm (speed of one rotation for 3 s), measure the rotational torque as the angular contact ball bearing preload.

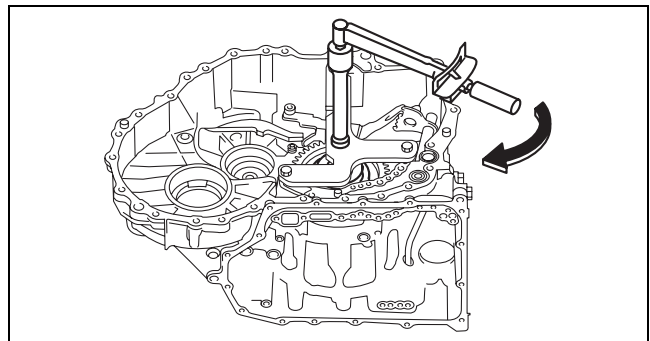

azzjjw00001579

(3) Input the measured angular contact ball bearing preload into the measurement/adjustment value sheet.

AUTOMATIC TRANSAXLE

(4) Remove the torque wrench.

A : Torque wrench

Note

- Because the SSTs and extension bar are used for secondary gear and output gear preload measurement/adjustment, do not remove them.

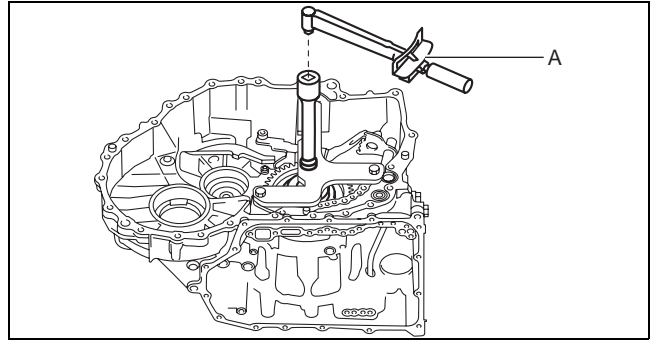

azzjw00001580

5. Assemble the secondary gear and output gear using the following procedure:

(1) Apply ATF (ATF FZ) to the taper roller bearing roller of the secondary gear and output gear.

A : ATF application area

Caution

- Accurately perform the procedure to reduce the error on the secondary gear and output gear preload measurement.

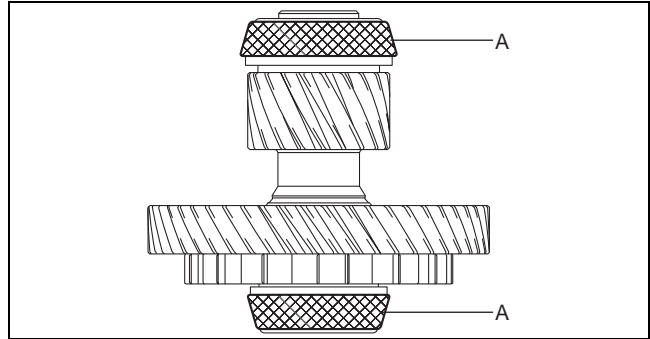

azzjw00000756

(2) Assemble the secondary gear and output gear.

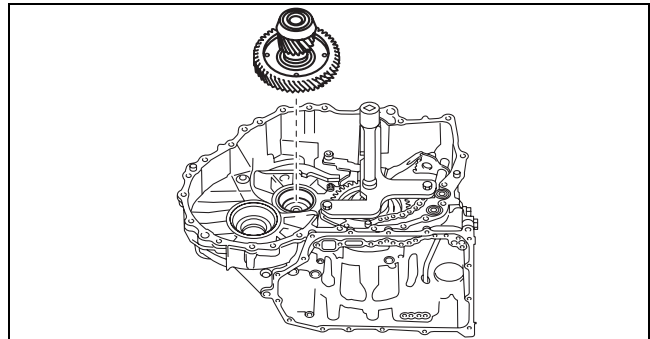

azzjw00001581

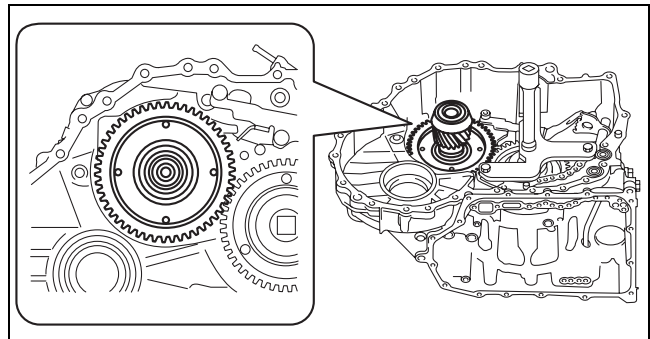

azzjw00001582

AUTOMATIC TRANSAXLE

6. Assemble the bearing race and a new shim with the same thickness as the removed shim to the converter housing using the following procedure:

Caution

- Always use a new shim. If a deformed shim is reused, it may cause a transaxle malfunction.

- (1) Apply ATF (ATF FZ) to the engagement area of the bearing race and converter housing.
- (2) Assemble the bearing race and a new shim with the same thickness as the removed shim using the following procedure and the SST:

1	Shim (outer diameter approx. 74 mm {2.9 in}) (new shim with same thickness of removed shim)
2	Bearing race (outer diameter approx. 75 mm {3.0 in})

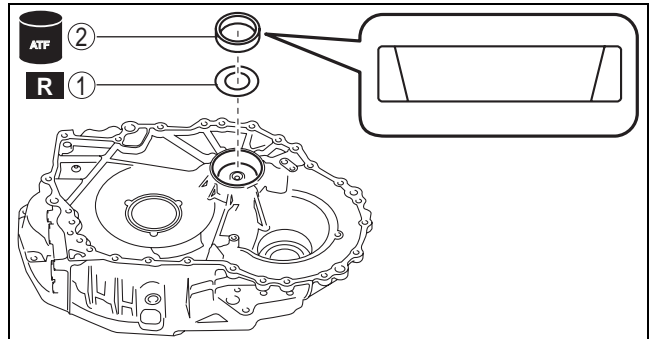

azzjjw00000759

05-17

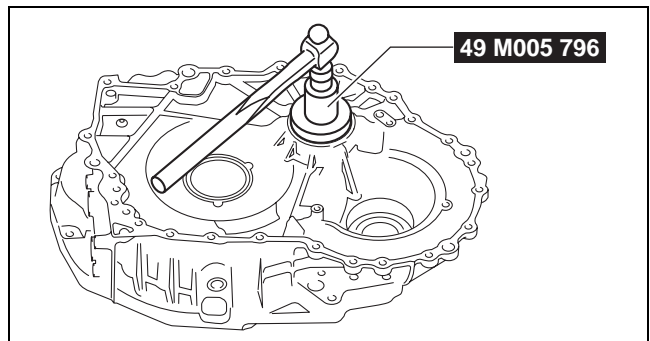

azzjjw00000760

7. Assemble the converter housing using the following procedure:

1	Converter housing
2	24 bolts (M8×1.25 bolt, length to approx. 28 mm {1.1 in})

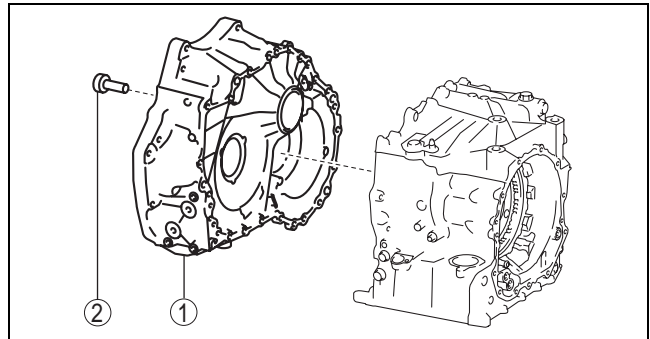

azzjjw00000761

- (1) Assemble the converter housing.

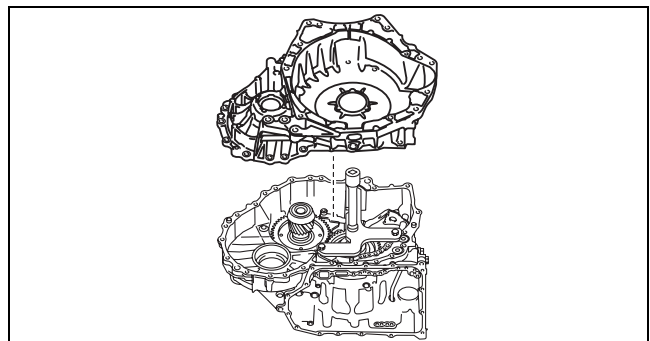

azzjjw00001583

AUTOMATIC TRANSAXLE

(2) Assemble and temporarily tighten the bolts to the positions shown in the figure.

Note

- Bolt size: M8×1.25 bolt, length to approx. 28 mm {1.1 in}

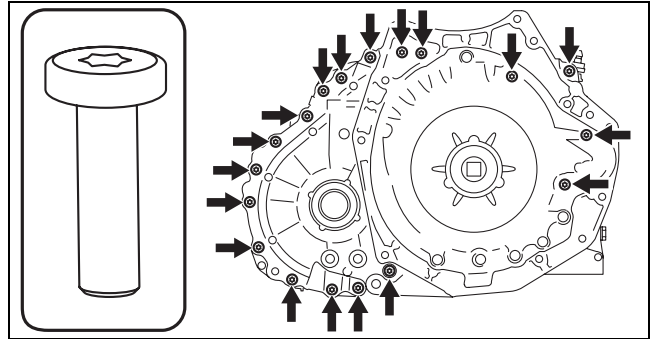

azzjiw00000763

(3) Assemble and temporarily tighten the bolts to the positions shown in the figure.

Caution

- **When performing the automatic transaxle assembly after the secondary gear and output gear preload measurement/adjustment, use new bolts, otherwise ATF leakage could occur.**

Note

- The bolts for the assembly are applied with sealant. However, the bolts are reused for removal after the secondary gear and output gear preload measurement/adjustment.
- Bolt size: M8×1.25 bolt, length to approx. 28 mm {1.1 in}

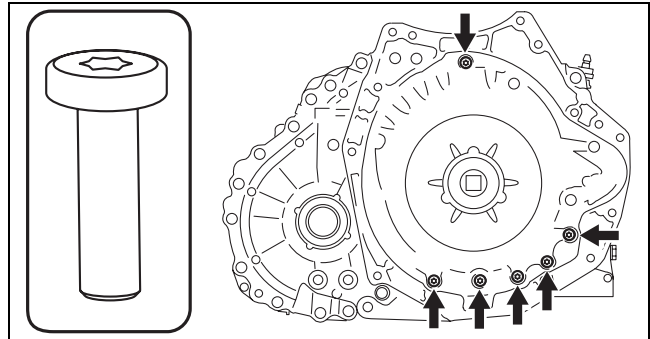

azzjiw00000764

(4) Tighten the bolts shown in the figure.

Tightening torque

19—25 N·m {2.0—2.5 kgf·m, 15—18 ft·lbf}

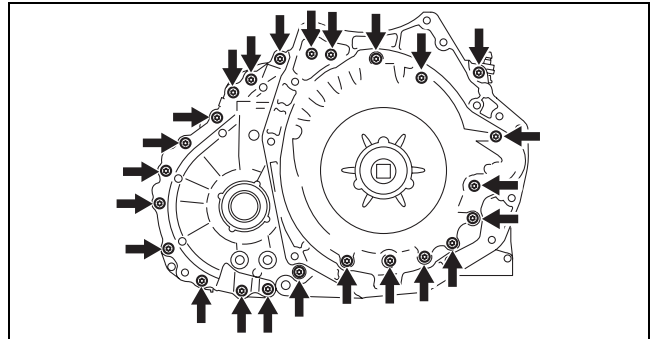

azzjiw00000765

AUTOMATIC TRANSAXLE

8. Measure the total preload using the following procedure:

Note

- The total preload is the combined preload of the angular contact ball bearing preload and secondary gear and output gear preload.

(1) Set the torque wrench to the extension bar as shown in the figure.

- A : Extension bar
B : Torque wrench

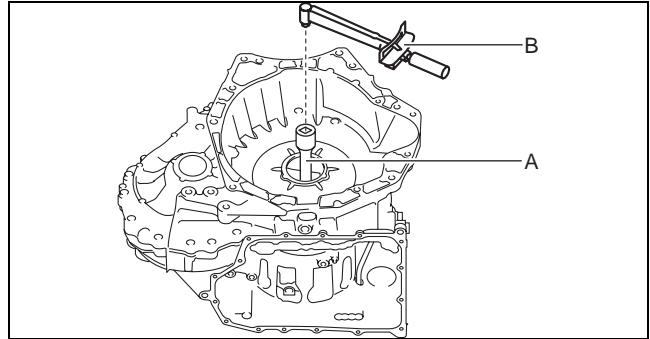

azzijw00001584

- A : Extension bar
B : Torque wrench

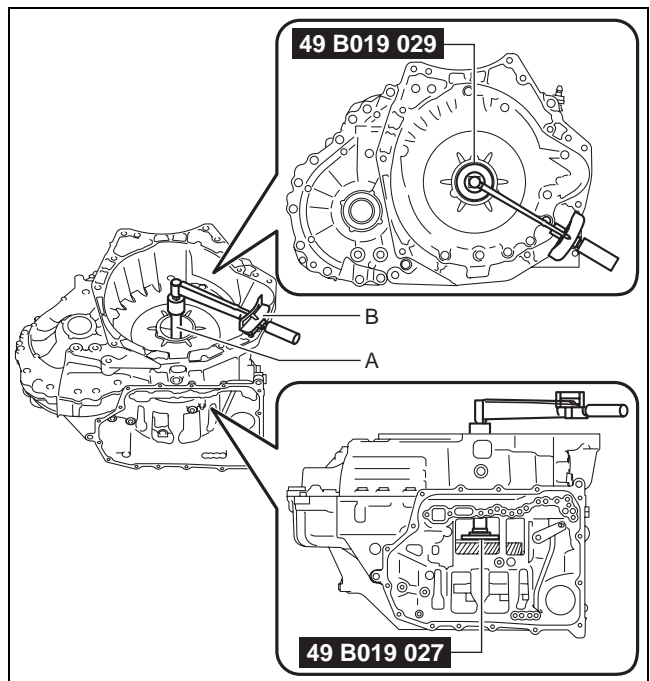

azzijw00001585

(2) Rotate the locknut (primary gear) in the direction of the arrow shown in the figure using a torque wrench and measure the total preload.

Caution

- Measure the total preload after rotating the locknut (primary gear) approx. 10 times in the direction of the arrow shown in the figure to engage the taper roller bearing.
- When the locknut (primary gear) is rotated at approx. 20 rpm (speed of one rotation for 3 s), measure the rotational torque as the total preload.

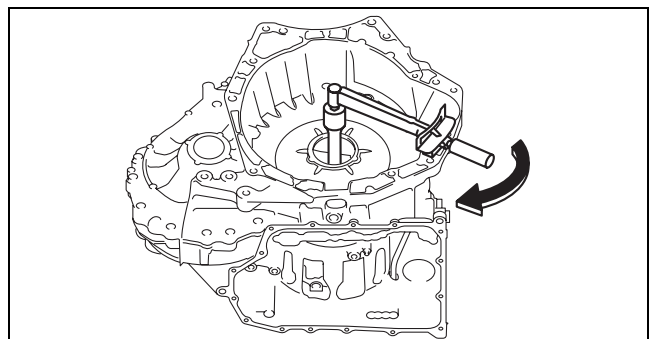

azzijw00000768

(3) Input the measured total preload into the measurement/adjustment value sheet.

05-17

AUTOMATIC TRANSAXLE

(4) Remove the torque wrench from the extension bar.

A : Extension bar
B : Torque wrench

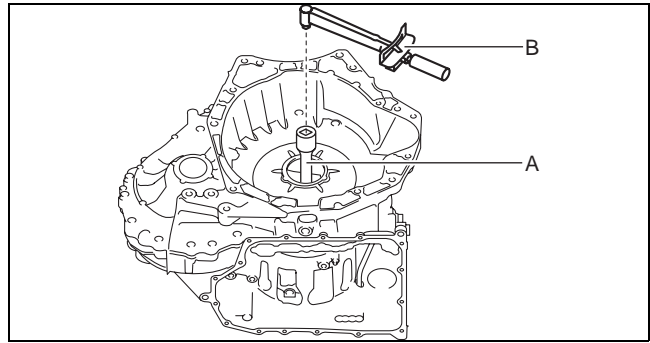

azzjw00001584

9. Remove the converter housing using the following procedure:

1	24 bolts
2	Converter housing

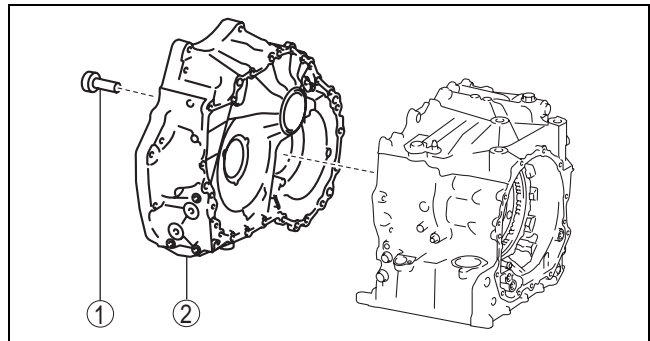

azzjw00000769

(1) Remove the bolts shown in the figure.

Caution

- Sealant has been applied to the removed bolts. If the bolts are reused it could cause ATF leakage, therefore when performing the automatic transaxle assembly, use new bolts.

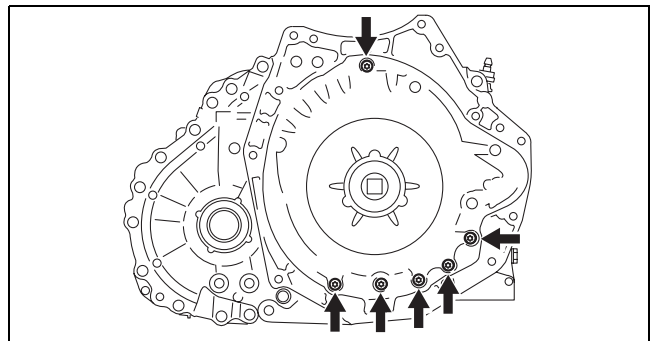

azzjw00000770

(2) Remove the bolts shown in the figure.

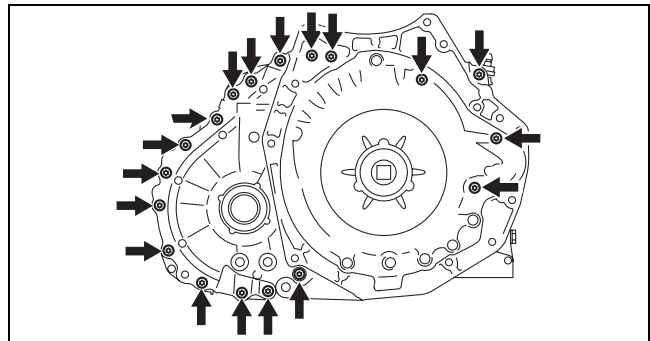

azzjw00000771

(3) Remove the converter housing.

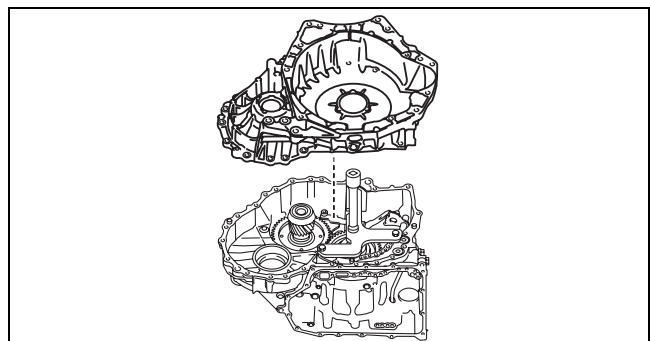

azzjw00001583

AUTOMATIC TRANSAXLE

10. Perform the following calculation to calculate the secondary gear and output gear preload.

Secondary gear and output gear preload = B - A

A: Angular contact ball bearing preload

B: Total preload

Note

Example

A: Angular contact ball bearing preload is 1.2 N·m {12.2 kgf·cm, 10.6 in·lbf}

B: Total preload is 3.7 N·m {37.7 kgf·cm, 32.7 in·lbf}

Secondary gear and output gear preload = 3.7 N·m {37.7 kgf·cm, 32.7 in·lbf} - 1.2 N·m {12.2 kgf·cm, 10.6 in·lbf} = 2.5 N·m {25.5 kgf·cm, 22.1 in·lbf}

11. Input the calculated secondary gear and output gear preload into the measurement/adjustment value sheet.

12. Verify that the secondary gear and output gear preload satisfies the specification.

Specification

2.8—3.7 N·m {28.6—37.7 kgf·cm, 24.8—32.7 in·lbf}

- If not within the specification, adjust the secondary gear and output gear preload. (See 05-17-372 Secondary Gear and Output Gear Preload Adjustment.)

13. Remove the secondary gear and output gear.

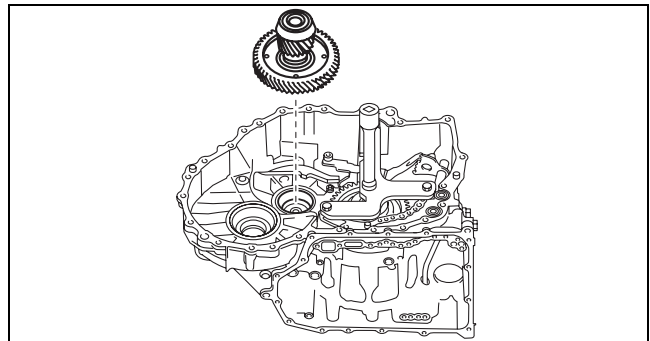

14. Remove the SST and extension bar.

A : Extension bar

B : Bolt supplied with SST (49 B019 029) or M8×1.25, length to 18 mm {0.71 in}

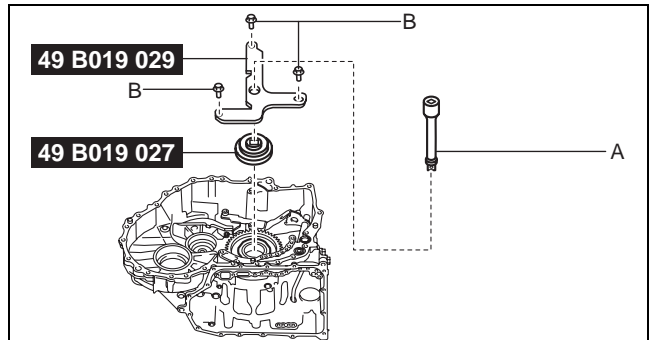

15. Rotate the parking shift lever component to the P position as shown in the figure.

A : Parking shift lever component

B : Manual plate component

C : Detent bracket component

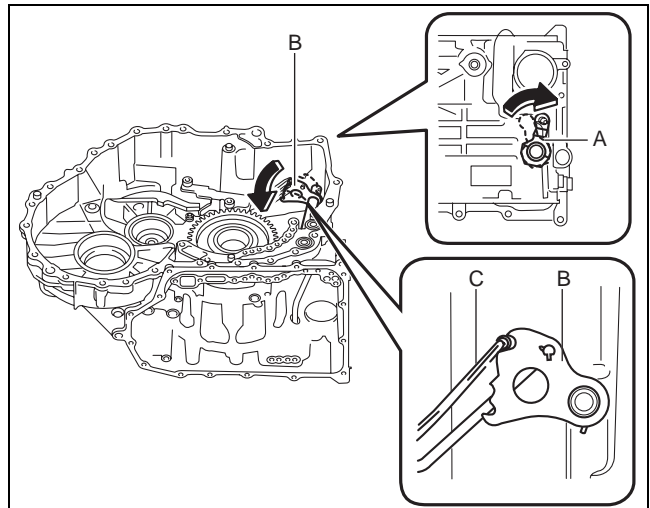

AUTOMATIC TRANSAXLE

Secondary Gear and Output Gear Preload Adjustment

1. Remove the bearing race and shim from the converter housing using the SST and procedure shown in the figure.

Caution

- Because the shim will deform when removing the bearing race, use a new shim when performing the shim assembly.

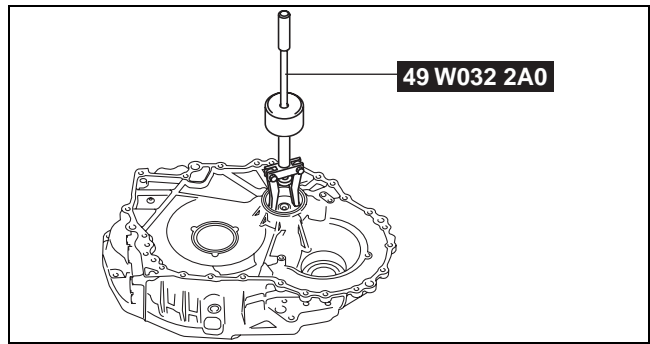

azzjw00000774

1	Bearing race
2	Shim

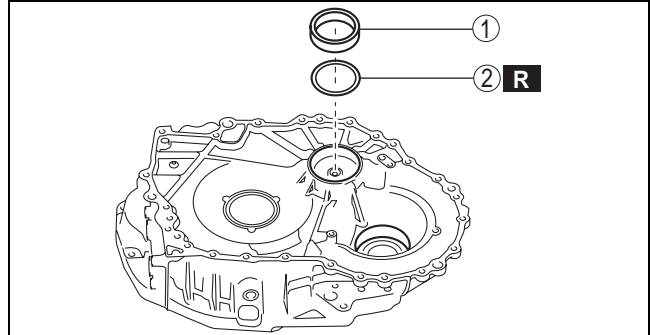

azzjw00000775

2. Measure the thickness of the removed shim.

Note

- Recommended measuring instrument: Micrometer

3. Input the measured shim thickness into the measurement/adjustment value sheet.
4. Perform the following calculation to calculate the preload gap.

Note

- The preload gap is the difference between the secondary gear and output gear preload and the median value of the secondary gear and output gear preload specification.

Preload gap = G - C

C: Secondary gear and output gear preload

G: Median value of secondary gear and output gear preload specification (3.25 N·m {33.1 kgf·cm, 28.7 in·lbf})

Note

Example

C: Secondary gear and output gear preload is 2.5 N·m {25.5 kgf·cm, 22.1 in·lbf}

Preload gap = 3.25 N·m {33.1 kgf·cm, 28.7 in·lbf} - 2.5 N·m {25.5 kgf·cm, 22.1 in·lbf} = 0.75 N·m {7.6 kgf·cm, 6.6 in·lbf}

5. Input the calculated preload gap into the measurement/adjustment value sheet.

AUTOMATIC TRANSAXLE

6. Perform the following calculation to calculate the gap in the shim thickness.

Note

- The gap in the shim thickness is the difference between the removed shim thickness and the optimum shim thickness.
- If the shim thickness is thickened 0.1 mm {0.00394 in}, the secondary gear and output gear preload increases approx. 1.6 N·m {16.3 kgf·cm, 14.1 in·lbf}.

Shim thickness gap = $H \times 0.1 \text{ mm } \{0.00394 \text{ in}\} / 1.6 \text{ N}\cdot\text{m } \{16.3 \text{ kgf}\cdot\text{cm, } 14.1 \text{ in}\cdot\text{lbf}\}$

H: Preload gap

Note

Example

H: Preload gap is 0.75 N·m {7.6 kgf·cm, 6.6 in·lbf}

Shim thickness gap = $0.75 \text{ N}\cdot\text{m } \{7.6 \text{ kgf}\cdot\text{cm, } 6.6 \text{ in}\cdot\text{lbf}\} \times 0.1 \text{ mm } \{0.00394 \text{ in}\} / 1.6 \text{ N}\cdot\text{m } \{16.3 \text{ kgf}\cdot\text{cm, } 14.1 \text{ in}\cdot\text{lbf}\} = 0.047 \text{ mm } \{0.00185 \text{ in}\}$

7. Input the calculated shim thickness gap into the measurement/adjustment value sheet.

8. Perform the following calculation to calculate the optimum shim thickness.

Optimum shim thickness = $F + I$

F: Thickness of removed shim

I: Shim thickness gap

Note

Example

F: Thickness of removed shim is 0.855 mm {0.03366 in}

I: Shim thickness gap is 0.047 mm {0.00185 in}

Thickness of optimum shim = $0.855 \text{ mm } \{0.03366 \text{ in}\} + 0.047 \text{ mm } \{0.00185 \text{ in}\} = 0.902 \text{ mm } \{0.03551 \text{ in}\}$

9. Input the calculated optimum shim thickness into the measurement/adjustment value sheet.

10. Select the nearest new shim for the calculated optimum shim thickness from the following table:

Selected shim thickness
1.45 mm {0.0571 in}
1.40 mm {0.0551 in}
1.35 mm {0.0531 in}
1.30 mm {0.0512 in}
1.25 mm {0.0492 in}
1.20 mm {0.0472 in}
1.15 mm {0.0453 in}
1.10 mm {0.0433 in}
1.05 mm {0.0413 in}
1.00 mm {0.0394 in}
0.95 mm {0.0374 in}
0.90 mm {0.0354 in}
0.85 mm {0.0335 in}
0.80 mm {0.0315 in}
0.75 mm {0.0295 in}
0.70 mm {0.0276 in}
0.65 mm {0.0256 in}
0.60 mm {0.0236 in}
0.55 mm {0.0217 in}
0.50 mm {0.0197 in}

05-17

AUTOMATIC TRANSAXLE

11. Assemble the bearing race and selected new shim to the converter housing using the following procedure:

Caution

- Always use a new shim. If a deformed shim is reused, it may cause a transaxle malfunction.

- (1) Apply ATF (ATF FZ) to the engagement area of the bearing race and converter housing.
- (2) Assemble the bearing race and selected new shim using the following procedure and SST:

1	Shim (outer diameter approx. 74 mm {2.9 in}) (selected new shim)
2	Bearing race (outer diameter approx. 75 mm {3.0 in})

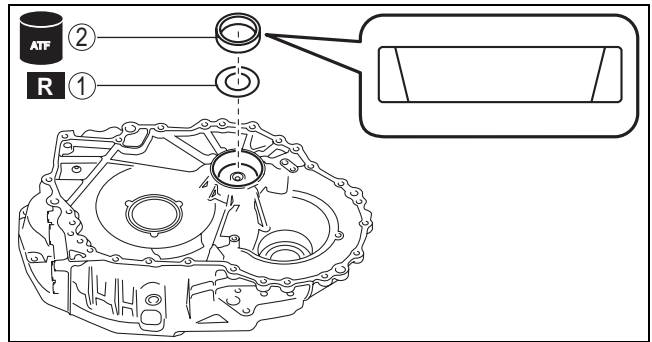

azzjiw00000759

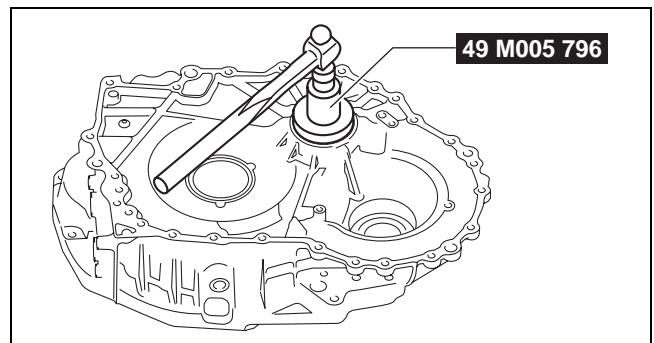

azzjiw00000760

12. Perform the secondary gear and output gear preload measurement from Step 7. (See 05-17-364 Secondary Gear and Output Gear Preload Measurement.)

AUTOMATIC TRANSAXLE

RING GEAR AND DIFFERENTIAL PRELOAD MEASUREMENT/ADJUSTMENT

id051700665100

Preparation Before Servicing

1. Print out the measurement/adjustment value input sheet. (See 05-17-295 MEASUREMENT/ADJUSTMENT VALUE INPUT SHEET.)

Note

- When performing the measurement/adjustment, input the measured and calculated values into the measurement/adjustment value input sheet.
- When performing the other measurements/adjustments, if the measurement/adjustment value input sheet has been printed out, use the printed sheet.

05-17

Ring Gear and Differential Preload Measurement

1. Rotate and adjust the rotation handle of the engine stand so that the converter housing side is facing upward.

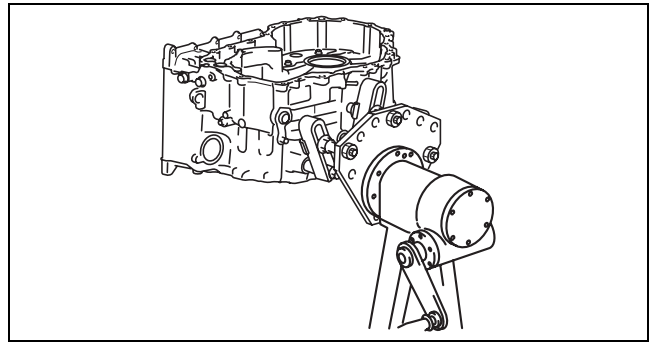

azzjjw00000776

2. Remove any remaining old sealant on the contact surfaces of the transaxle case and converter housing.
3. Assemble the ring gear and differential.
 - (1) Apply ATF (ATF FZ) to the roller area of the taper roller bearing of the ring gear and differential.

A : ATF application area

Caution

- Accurately perform the procedure to reduce the error on the ring gear and differential preload measurement.

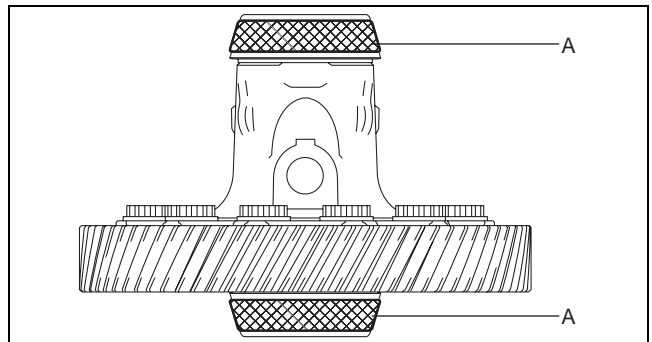

azzjjw00000777

AUTOMATIC TRANSAXLE

(2) Assemble the ring gear and differential.

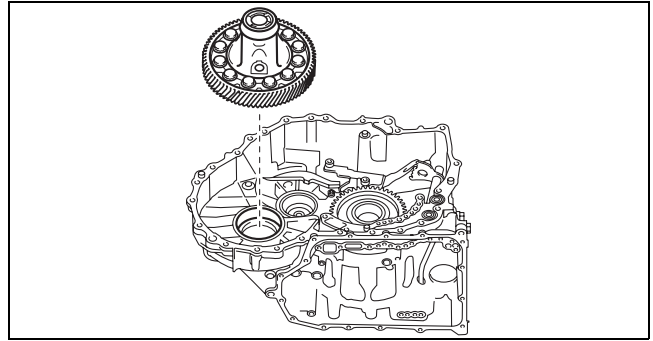

azzjiw00000778

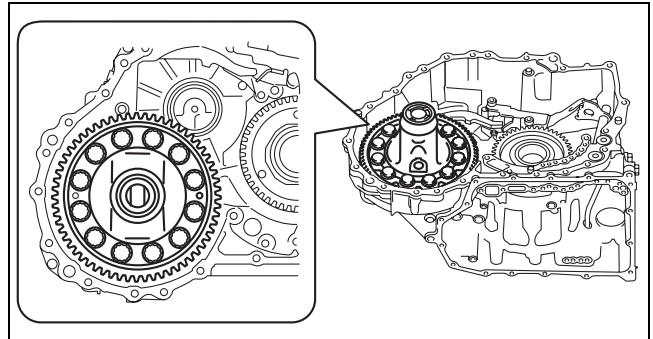

azzjiw00000779

4. Assemble the bearing race and a new shim with the same thickness as the removed shim to the converter housing using the following procedure:

Caution

- Always use a new shim. If a deformed shim is reused, it may cause a transaxle malfunction.

- (1) Apply ATF (ATF FZ) to the engagement area of the bearing race and converter housing.
- (2) Assemble the bearing race and a new shim with the same thickness as the removed shim using the following procedure and the SST:

1	Shim (outer diameter approx. 79 mm {3.1 in}) (new shim with same thickness of removed shim)
2	Bearing race (outer diameter approx. 80 mm {3.1 in})

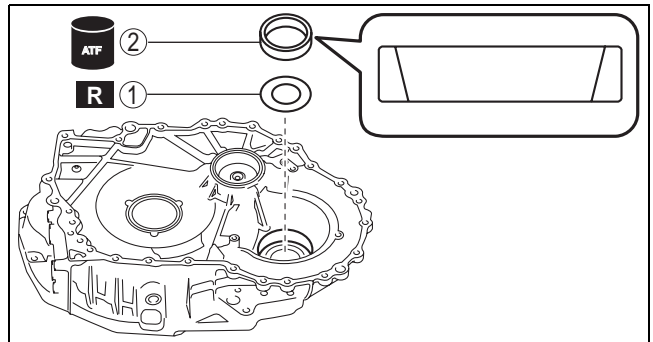

azzjiw00000780

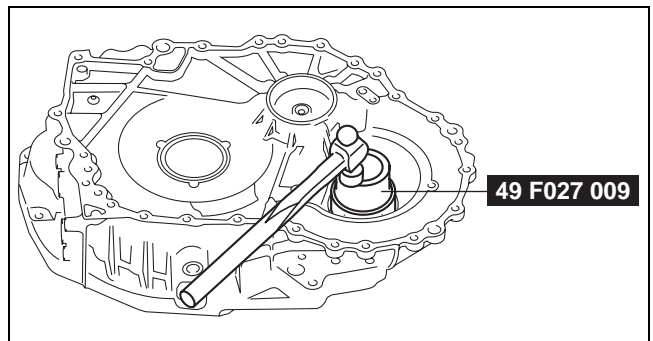

azzjiw00000781

AUTOMATIC TRANSAXLE

5. Assemble the converter housing using the following procedure:

1	Converter housing
2	24 bolts (M8×1.25 bolt, length to approx. 28 mm {1.1 in})

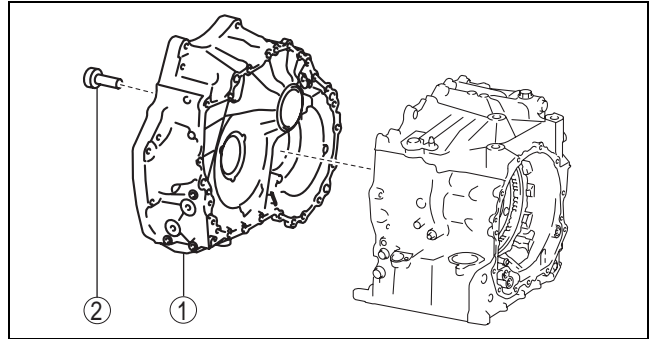

azzjw00000782

05-17

(1) Assemble the converter housing.

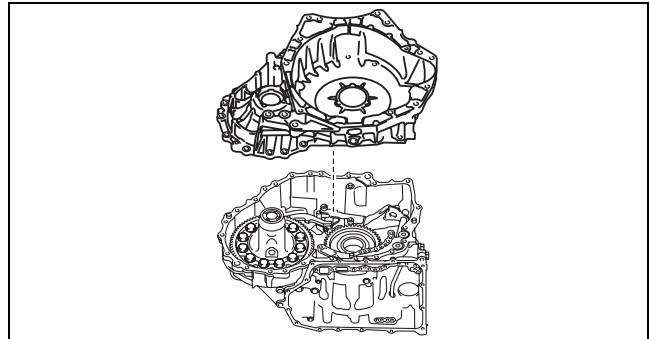

azzjw00000783

(2) Assemble and temporarily tighten the bolts to the positions shown in the figure.

Note

- Bolt size: M8×1.25 bolt, length to approx. 28 mm {1.1 in}

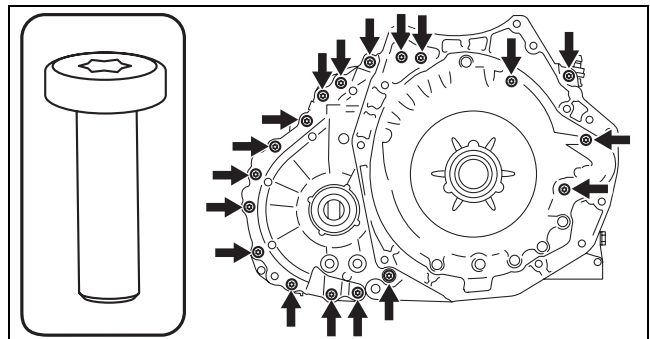

azzjw00000784

(3) Assemble and temporarily tighten the bolts to the positions shown in the figure.

Caution

- **When performing the automatic transaxle assembly after the ring gear and differential preload measurement/adjustment, use new bolts, otherwise ATF leakage could occur.**

Note

- The bolts for the assembly are applied with sealant. However, the bolts are reused for removal after the ring gear and differential preload measurement/adjustment.
- Bolt size: M8×1.25 bolt, length to approx. 28 mm {1.1 in}

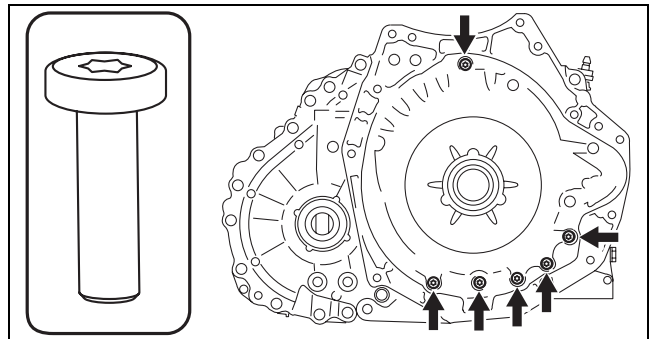

azzjw00000785

AUTOMATIC TRANSAXLE

(4) Tighten the bolts shown in the figure.

Tightening torque

19—25 N·m {2.0—2.5 kgf·m, 15—18 ft·lbf}

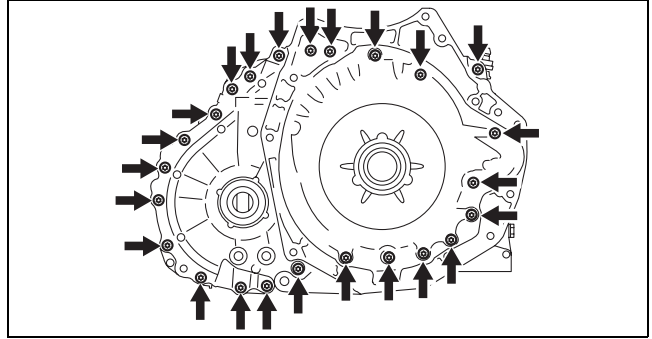

azzijw00000786

6. Measure the ring gear and differential preload using the following procedure.

(1) Set the SST, torque wrench, and socket (14 mm {9/16 in}) as shown in the figure.

A : Torque wrench

B : Socket (14 mm {9/16 in})

Note

- Engage the groove on the end of the SST with the pinion shaft.

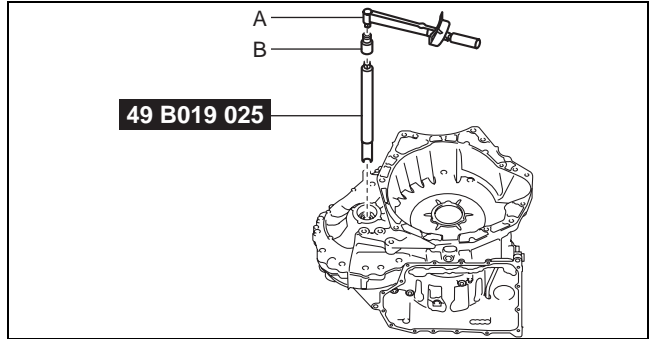

azzijw00000787

A : Torque wrench

B : Socket (14 mm {9/16 in})

C : Pinion shaft

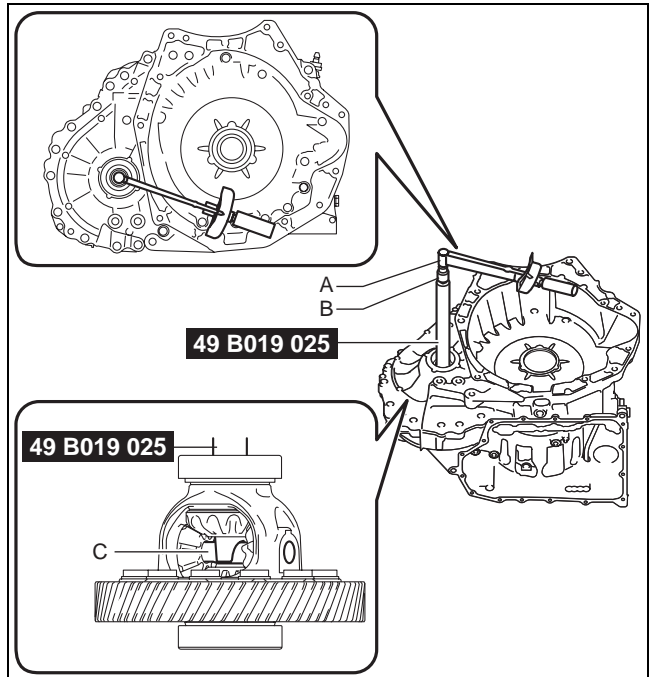

azzijw00000788

AUTOMATIC TRANSAXLE

- (2) Rotate the ring gear and differential in the direction of the arrow shown in the figure using a torque wrench and measure the ring gear and differential preload.

Caution

- Measure the ring gear and differential preload after rotating the ring gear and differential approx. 10 times in the direction of the arrow shown in the figure to engage the taper roller bearing.
- When the ring gear and differential is rotated at approx. 20 rpm (speed of one rotation for 3 s), measure the rotational torque as a ring gear and differential preload.

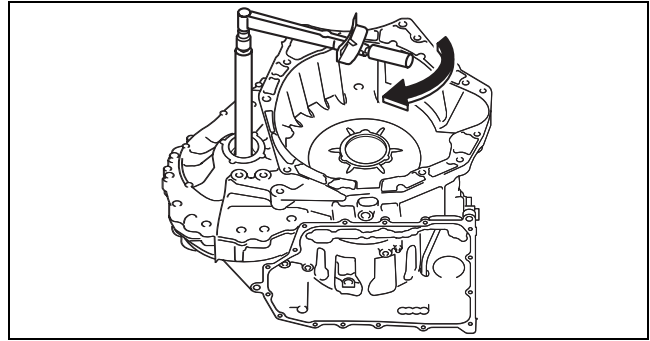

azzjw00000789

05-17

- (3) Input the measured ring gear and differential preload into the measurement/adjustment value sheet.
 (4) Verify that the ring gear and differential preload satisfies the specification.

Specification

2.8—4.1 N·m {28.6—41.8 kgf·cm, 24.8—36.2 in·lbf}

- If not within the specification, perform adjustment of the ring gear and differential preload. (See 05-17-381 Ring Gear and Differential Preload Adjustment.)

- (5) Remove the SST, torque wrench, and socket (14 mm {9/16 in}).

- A : Torque wrench
 B : Socket (14 mm {9/16 in})

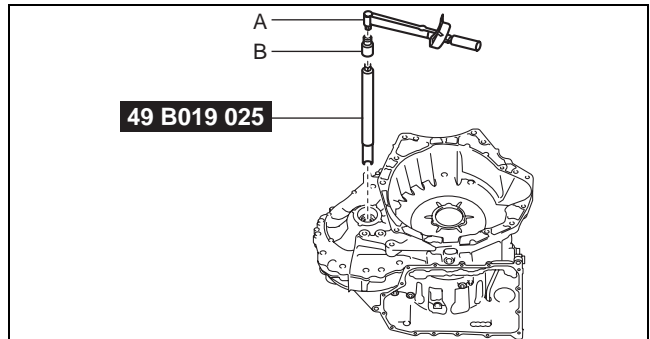

azzjw00000787

7. Remove the converter housing using the following procedure:

1	24 bolts
2	Converter housing

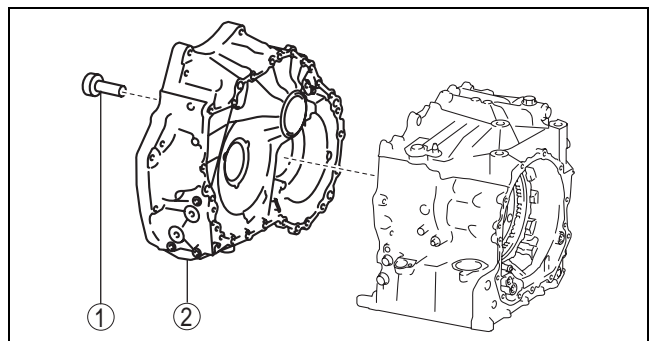

azzjw00000790

AUTOMATIC TRANSAXLE

(1) Remove the bolts shown in the figure.

Caution

- Sealant has been applied to the removed bolts. If the bolts are reused it could cause ATF leakage, therefore when performing the automatic transaxle assembly, use new bolts.

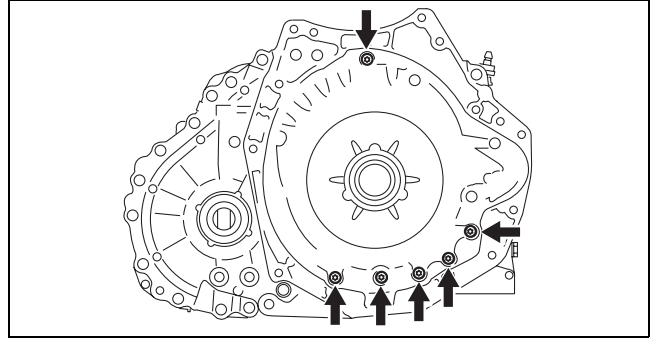

azzjw00000791

(2) Remove the bolts shown in the figure.

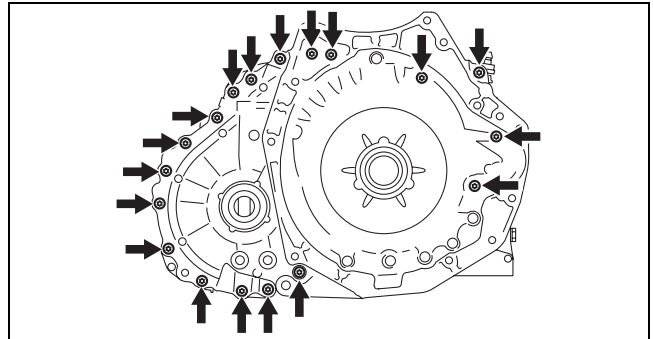

azzjw00000792

(3) Remove the converter housing.

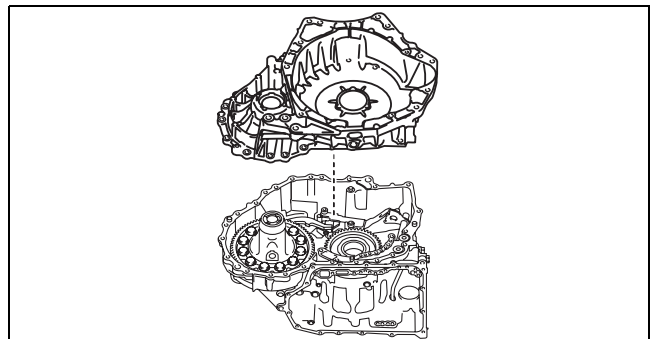

azzjw00000783

8. Remove the ring gear and differential.

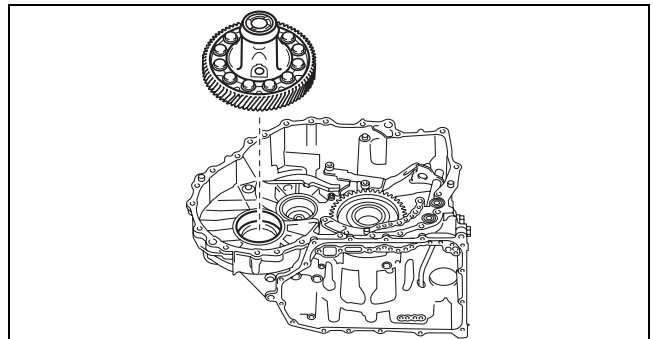

azzjw00000778

AUTOMATIC TRANSAXLE

Ring Gear and Differential Preload Adjustment

1. Remove the SST, torque wrench, and socket (14 mm {9/16 in}).

A : Torque wrench

B : Socket (14 mm {9/16 in})

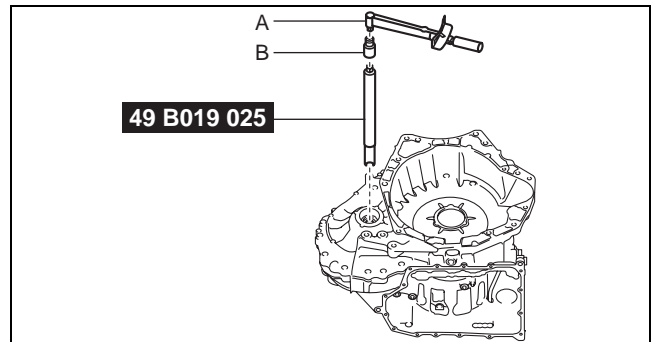

azzjjw00000787

05-17

2. Remove the converter housing using the following procedure:

1	24 bolts
2	Converter housing

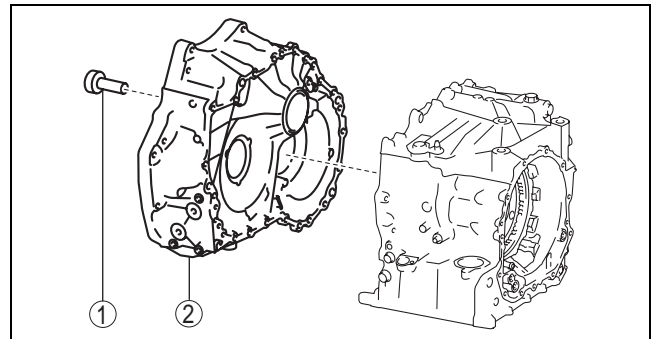

azzjjw00000790

- (1) Remove the bolts shown in the figure.

Caution

- Sealant has been applied to the removed bolts. If the bolts are reused it could cause ATF leakage, therefore when performing the automatic transaxle assembly, use new bolts.

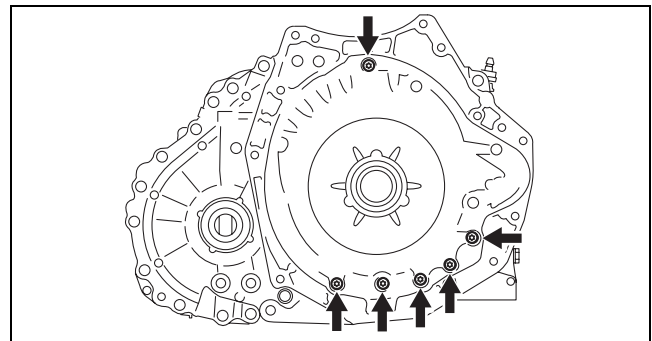

azzjjw00000791

- (2) Remove the bolts shown in the figure.

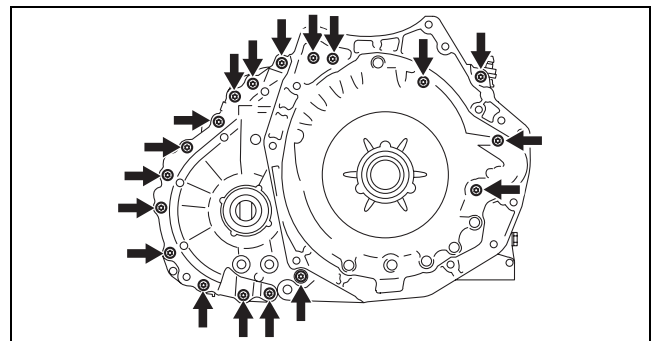

azzjjw00000792

AUTOMATIC TRANSAXLE

(3) Remove the converter housing.

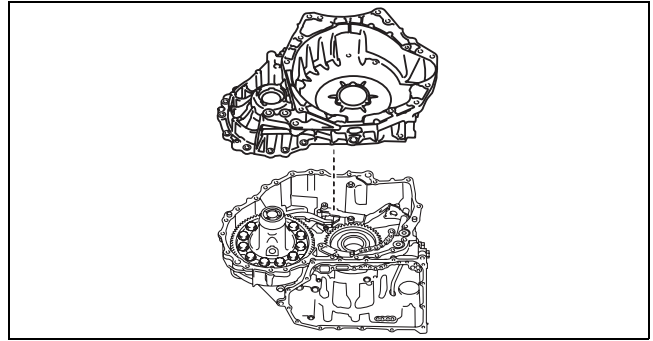

azzjiw00000783

3. Remove the bearing race and shim from the converter housing using the SSTs and procedure shown in the figure.

Caution

- Because the shim will deform when removing the bearing race, use a new shim when performing the shim assembly.

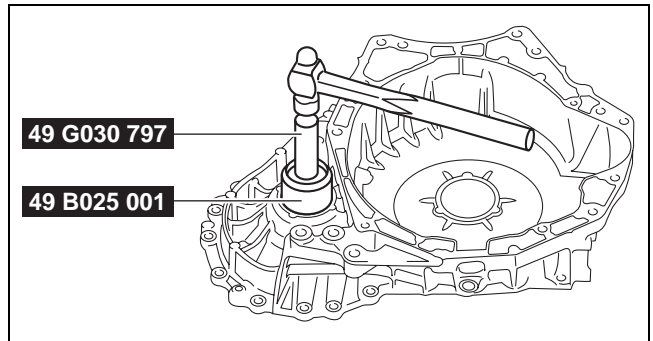

azzjiw00000793

1	Bearing race
2	Shim

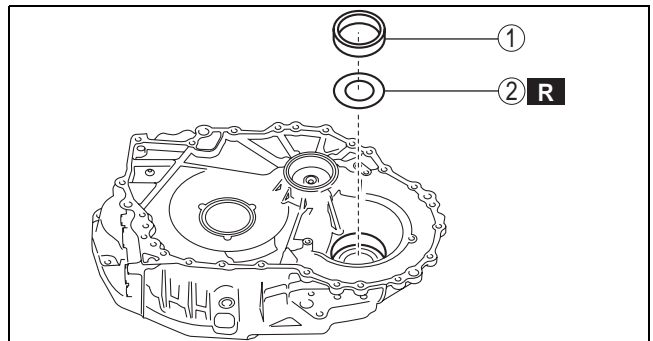

azzjiw00000794

4. Measure the thickness of the removed shim.

Note

- Recommended measuring instrument: Micrometer

5. Input the measured shim thickness into the measurement/adjustment value sheet.

6. Perform the following calculation to calculate the preload gap.

Note

- The preload gap is the difference between the ring gear and differential preload and the median value of the ring gear and differential preload specification.

Preload gap = E – A

A: Ring gear and differential preload

E: Median value of ring gear and differential preload specification (3.45 N·m {35.2 kgf·cm, 30.5 in·lbf})

Note

Example

A: Ring gear and differential preload is 2.5 N·m {25.5 kgf·cm, 22.1 in·lbf}

Preload gap = 3.45 N·m {35.2 kgf·cm, 30.5 in·lbf} - 2.5 N·m {25.5 kgf·cm, 22.1 in·lbf} = 0.95 N·m {9.7 kgf·cm, 8.4 in·lbf}

7. Input the calculated preload gap into the measurement/adjustment value sheet.

AUTOMATIC TRANSAXLE

8. Perform the following calculation to calculate the gap in the shim thickness.

Note

- The gap in the shim thickness is the difference between the removed shim thickness and the optimum shim thickness.
- If the shim thickness is thickened 0.1 mm {0.00394 in}, the ring gear and differential preload increases approx. 1.5 N·m {15.3 kgf·cm, 13.3 in·lbf}.

Shim thickness gap = $F \times 0.1 \text{ mm } \{0.00394 \text{ in}\} / 1.5 \text{ N}\cdot\text{m } \{15.3 \text{ kgf}\cdot\text{cm, } 13.3 \text{ in}\cdot\text{lbf}\}$

F: Preload gap

Note

Example

F: Preload gap is 0.95 N·m {9.7 kgf·cm, 8.4 in·lbf}

Shim thickness gap = $0.95 \text{ N}\cdot\text{m } \{9.7 \text{ kgf}\cdot\text{cm, } 8.4 \text{ in}\cdot\text{lbf}\} \times 0.1 \text{ mm } \{0.00394 \text{ in}\} / 1.5 \text{ N}\cdot\text{m } \{15.3 \text{ kgf}\cdot\text{cm, } 13.3 \text{ in}\cdot\text{lbf}\} = 0.063 \text{ mm } \{0.00248 \text{ in}\}$

9. Input the calculated shim thickness gap into the measurement/adjustment value sheet.

10. Perform the following calculation to calculate the optimum shim thickness.

Optimum shim thickness = D + G

D: Thickness of removed shim

G: Shim thickness gap

Note

Example

D: Thickness of removed shim is 0.905 mm {0.03563 in}

G: Shim thickness gap is 0.063 mm {0.00248 in}

Thickness of optimum shim = $0.905 \text{ mm } \{0.03563 \text{ in}\} + 0.063 \text{ mm } \{0.00248 \text{ in}\} = 0.968 \text{ mm } \{0.03811 \text{ in}\}$

11. Input the calculated optimum shim thickness into the measurement/adjustment value sheet.

12. Select the nearest new shim for the calculated optimum shim thickness from the following table:

Selected shim thickness
1.55 mm {0.0610 in}
1.50 mm {0.0591 in}
1.45 mm {0.0571 in}
1.40 mm {0.0551 in}
1.35 mm {0.0531 in}
1.30 mm {0.0512 in}
1.25 mm {0.0492 in}
1.20 mm {0.0472 in}
1.15 mm {0.0453 in}
1.10 mm {0.0433 in}
1.05 mm {0.0413 in}
1.00 mm {0.0394 in}
0.95 mm {0.0374 in}
0.90 mm {0.0354 in}
0.85 mm {0.0335 in}
0.80 mm {0.0315 in}
0.75 mm {0.0295 in}
0.70 mm {0.0276 in}
0.65 mm {0.0256 in}
0.60 mm {0.0236 in}
0.55 mm {0.0217 in}

AUTOMATIC TRANSAXLE

13. Assemble the bearing race and selected new shim to the converter housing using the following procedure:

Caution

- Always use a new shim. If a deformed shim is reused, it may cause a transaxle malfunction.

- (1) Apply ATF (ATF FZ) to the engagement area of the bearing race and converter housing.
- (2) Assemble the bearing race and selected new shim using the following procedure and SST:

1	Shim (outer diameter approx. 79 mm {3.1 in}) (selected new shim)
2	Bearing race (outer diameter approx. 80 mm {3.1 in})

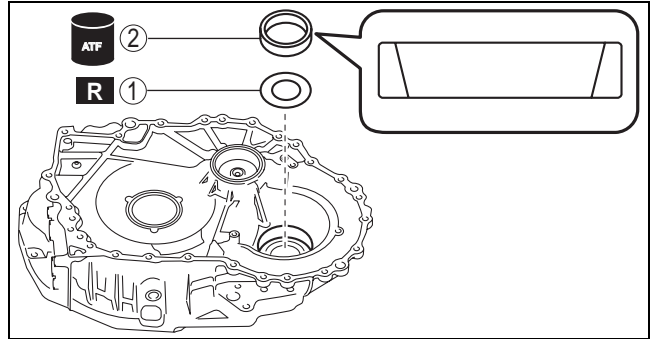

azzjw00000780

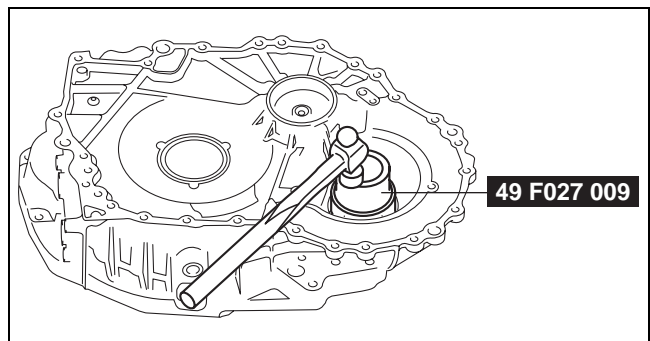

azzjw00000781

14. Perform ring gear and differential preload measurement from Step 5. (See 05-17-375 Ring Gear and Differential Preload Measurement.)

AUTOMATIC TRANSAXLE

TOTAL END PLAY MEASUREMENT/ADJUSTMENT

id051700665200

Caution

- The total end play is the play (gap) in the axial direction of each planetary gear.
- If the total end play adjustment is not performed, it may cause damage to the thrust needle bearing between each planetary gear or other parts. Accurately perform the following servicing.

Preparation Before Servicing

1. Print out the measurement/adjustment value input sheet. (See 05-17-295 MEASUREMENT/ADJUSTMENT VALUE INPUT SHEET.)

Note

- When performing the measurement/adjustment, input the measured and calculated values into the measurement/adjustment value input sheet.
- When performing the other measurements/adjustments, if the measurement/adjustment value input sheet has been printed out, use the printed sheet.

Total End Play Measurement/Adjustment

1. Rotate and adjust the rotation handle of the engine stand so that the end cover side is facing upward.

Caution

- To reduce error during the total end play measurement, adjust so that the alignment surface of the transaxle case with the end cover is level.

2. Remove any remaining old sealant on the contact surfaces of the transaxle case and end cover.
3. Assemble the shim (FZ01 19 2L1) for the total end play measurement/adjustment.

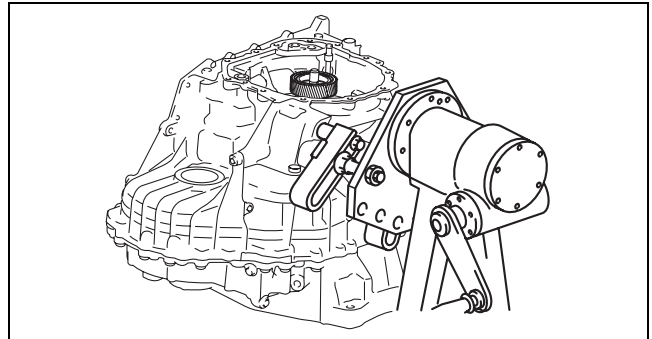

azzjw00000795

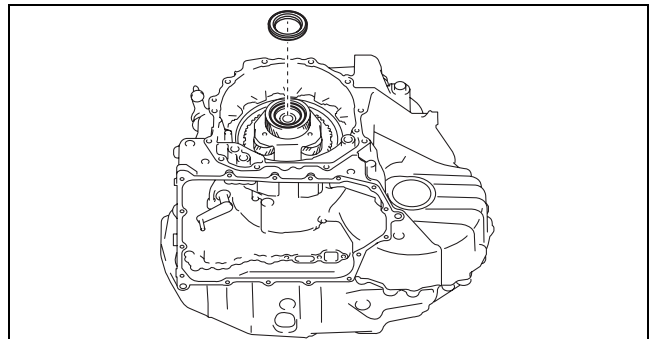

azzjw00000796

05-17

AUTOMATIC TRANSAXLE

4. Assemble the end cover component.

Note

- Adjust the oil pipe and assemble the end cover component so that the oil pipe is assembled to the end cover oil passage.

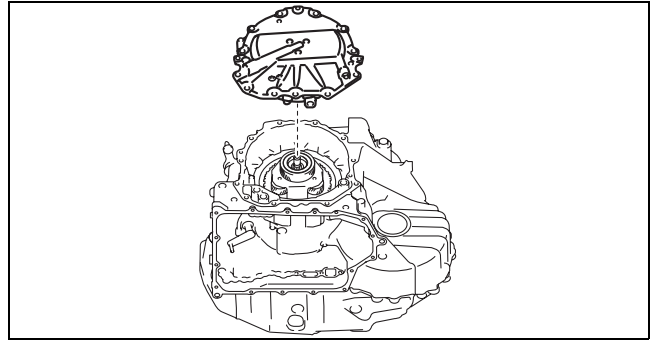

azzjiw00000797

A : End cover oil passage

B : Oil pipe

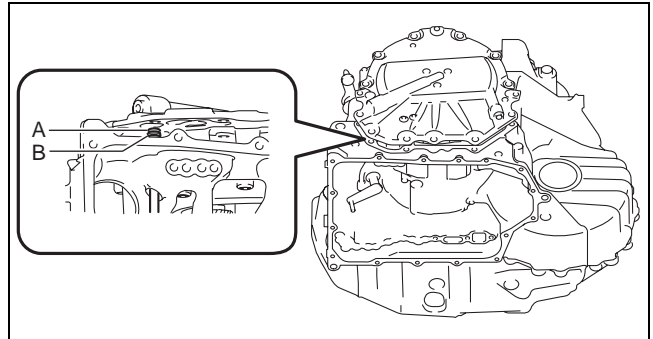

azzjiw00000798

5. Place a 98—196 N {10.0—19.9 kgf, 23.0—44.0 lbf} weight on the end cover.

A : Weight (V-block)

Note

- Use a V-block as a weight.
- To reduce error during the total end play measurement, place the weight near the center of the end cover.

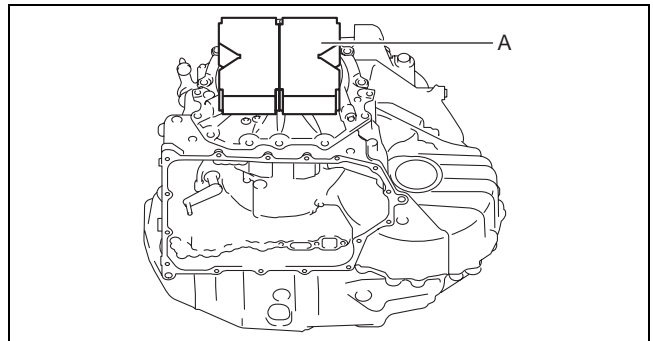

azzjiw00000799

6. Measure the total end play adjustment value using the following procedure:

Note

- The total end play adjustment value is the gap between the transaxle case and end cover with the shim (FZ01 19 2L1) for the total end play measurement/adjustment assembled.
- Recommended measuring instrument: Thickness gauge

(1) Measure the total end play adjustment value (gap between the transaxle case and end cover) in four locations (each separated by 90°) and calculate the average of the total end play adjustment value.

A : Total end play adjustment value

B : End cover end (alignment surface with transaxle case)

C : Transaxle case end (alignment surface with end cover)

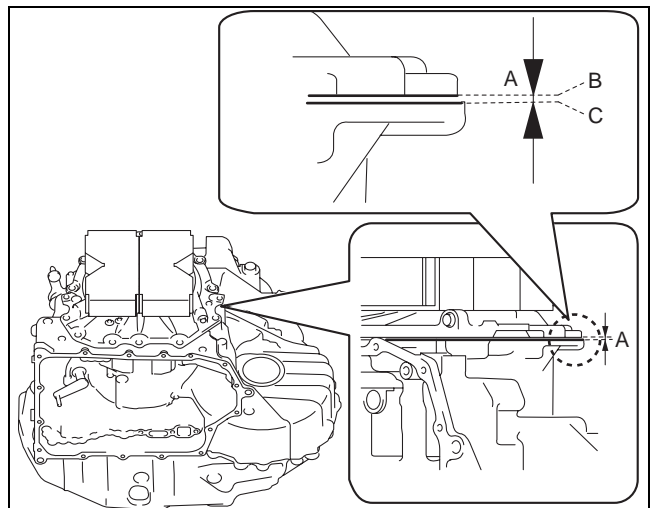

azzjiw00001576

AUTOMATIC TRANSAXLE

(2) Input the measured total end play adjustment value and calculated average of the total end play adjustment value into the measurement/adjustment value sheet.

7. Remove the weight on the end cover.

A : Weight (V-block)

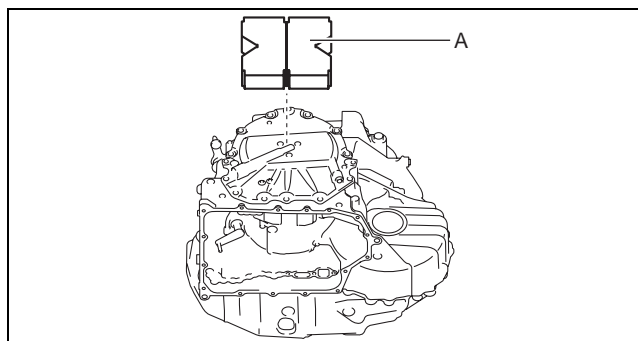

azzjw00000801

8. Remove the end cover component.

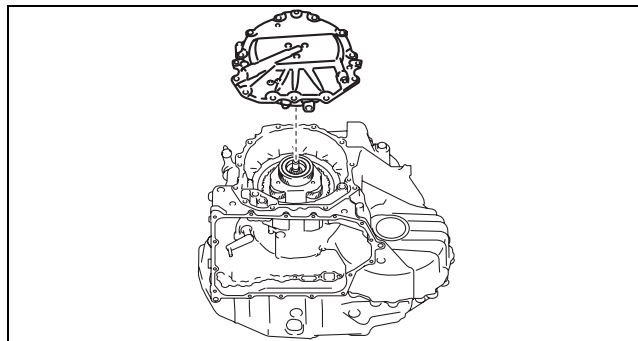

azzjw00000797

9. Remove the shim (FZ01 19 2L1) for the total end play measurement/adjustment.

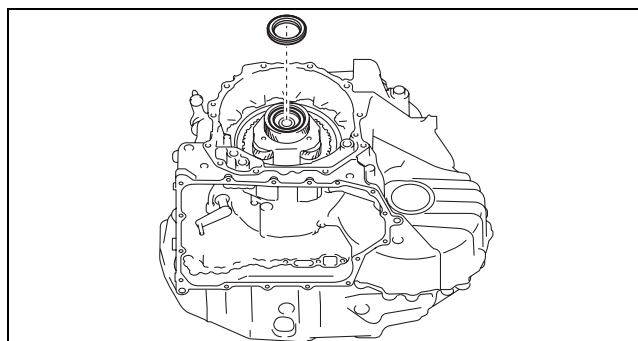

azzjw00000796

10. Measure the thickness of the removed shim (FZ01 19 2L1) for the total end play measurement/adjustment.

Note

- Recommended measuring instrument: Micrometer

11. Input the measured shim thickness into the measurement/adjustment value sheet.

AUTOMATIC TRANSAXLE

12. Select the appropriate shim from the following table.

Range*	Selected shim thickness
Exceeds 3.545 mm {0.1396 in}, 3.645 mm {0.1435 in} or less	3.0 mm {0.118 in}
Exceeds 3.445 mm {0.1356 in}, 3.545 mm {0.1396 in} or less	2.9 mm {0.114 in}
Exceeds 3.345 mm {0.1317 in}, 3.445 mm {0.1356 in} or less	2.8 mm {0.110 in}
Exceeds 3.245 mm {0.1278 in}, 3.345 mm {0.1317 in} or less	2.7 mm {0.106 in}
Exceeds 3.145 mm {0.1238 in}, 3.245 mm {0.1278 in} or less	2.6 mm {0.102 in}
Exceeds 3.045 mm {0.1199 in}, 3.145 mm {0.1238 in} or less	2.5 mm {0.098 in}
Exceeds 2.945 mm {0.1159 in}, 3.045 mm {0.1199 in} or less	2.4 mm {0.094 in}
Exceeds 2.845 mm {0.1120 in}, 2.945 mm {0.1159 in} or less	2.3 mm {0.091 in}
Exceeds 2.745 mm {0.1081 in}, 2.845 mm {0.1120 in} or less	2.2 mm {0.087 in}
Exceeds 2.645 mm {0.1041 in}, 2.745 mm {0.1081 in} or less	2.1 mm {0.083 in}

* : The range is the average value of the total end play adjustment value and the added thickness value of the removed shim (FZ01 19 2L1) for the total end play measurement/adjustment.

Range = B + C

B: Average adjustment of total end play

C: Thickness of shim (FZ01 19 2L1) for total end play measurement/adjustment

Note

Example

B: If the average of total end play adjustment value is 0.115 mm {0.00453 in}

C: If the thickness of the shim (FZ01 19 2L1) for the total end play measurement/adjustment is 3.010 mm {0.11850 in}

Range = 0.115 mm {0.00453 in} + 3.010 mm {0.11850 in} = 3.125 mm {0.12303 in}, the selected shim has a thickness of 2.5 mm {0.098 in}.

TECHNICAL DATA

05-50 TECHNICAL DATA

TECHNICAL DATA 05-50-1

TECHNICAL DATA

id055000800600

05-50

Item		Specification	Comment
Gap between front planetary gear pinion washer and planetary carrier	Maximum:	0.879 mm {0.0346 in}	—
Gap between rear planetary gear pinion washer and planetary carrier	Maximum:	0.879 mm {0.0346 in}	—
Gap between reduction planetary gear pinion washer and planetary carrier	Maximum:	0.820 mm {0.0322 in}	—
Inner diameter of reduction planetary gear bush	Maximum:	35.095 mm {1.3816 in}	—
Inner diameter of differential journal	Maximum:	30.046 mm {1.1829 in}	—
Outer diameter of drive shaft (LH) journal	Minimum	29.959 mm {1.1795 in}	—
Outer diameter of joint shaft journal	Minimum	29.944 mm {1.1789 in}	—
Thickness of low clutch drive plate	Minimum	1.475 mm {0.05808 in}	Drive plate size: Outer diameter approx. 159.1 mm {6.264 in}
Thickness of high clutch drive plate	Minimum	1.375 mm {0.05414 in}	Drive plate size: Outer diameter approx. 116.8 mm {4.598 in}
Free length of high clutch springs and retainer component	Minimum	25.4 mm {1.01 in}	Springs and retainer component size: Outer diameter approx. 79.5 mm {3.13 in}
Thickness of low and reverse brake drive plate	Minimum	1.475 mm {0.05808 in}	Drive plate size: Outer diameter approx. 174.1 mm {6.854 in}
Thickness of 2-6 brake drive plate	Minimum	1.475 mm {0.05808 in}	Drive plate size: Outer diameter approx. 171.9 mm {6.768 in}
Thickness of R-3-5 brake drive plate	Minimum	1.635 mm {0.06438 in}	Drive plate size: Outer diameter approx. 169.4 mm {6.669 in}
Inner diameter of low clutch hub bush	Maximum:	31.270 mm {1.2311 in}	—
Inner diameter of high clutch hub bush	Maximum:	18.038 mm {0.71015 in}	—
Oil pump side clearance (inner rotor)	Maximum:	0.045 mm {0.0017 in}	—
Oil pump side clearance (outer rotor)	Maximum:	0.050 mm {0.0019 in}	—
Inner diameter of oil pump (oil pump cover) bush	Maximum:	44.006 mm {1.7325 in}	—
Low clutch clearance	Specification	1.400—1.600 mm {0.05512—0.06299 in}	—
High clutch clearance	Specification	1.300—1.500 mm {0.05119—0.05905 in}	—
Low and reverse brake clearance	Specification	1.650—1.850 mm {0.06497—0.07283 in}	—
2-6 brake clearance	Specification	1.000—1.200 mm {0.03938—0.04724 in}	—
R-3-5 brake clearance	Specification	1.000—1.200 mm {0.03938—0.04724 in}	—
Differential backlash	Specification	0.030—0.150 mm {0.0012—0.0059 in}	—
Secondary gear and output gear preload	Specification	2.8—3.7 N·m {28.6—37.7 kgf·cm, 24.8—32.7 in·lbf}	—
Ring gear and differential preload	Specification	2.8—4.1 N·m {28.6—41.8 kgf·cm, 24.8—36.2 in·lbf}	—
Total end play	Specification	0.520—0.670 mm {0.0205—0.0263 in}	—

05-60 SERVICE TOOLS

SERVICE TOOLS 05-60-1

SERVICE TOOLS

id056000804300

05-60

Example of description



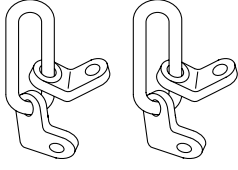

Ford manufactured **SSTs** are as follows: Mazda and Ford **SST** numbers can be referenced.

1:49 UN30 3050
2:303-050



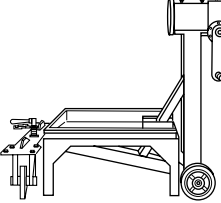
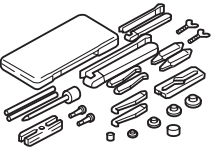
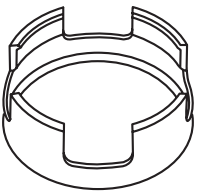
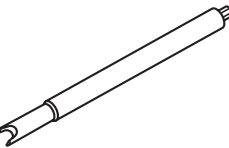
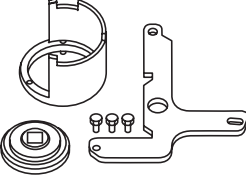
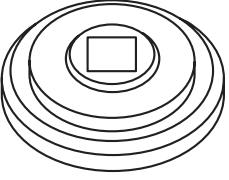
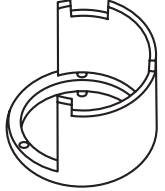
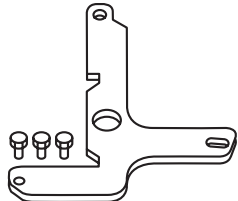

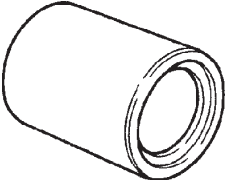
Engine lifting bracket

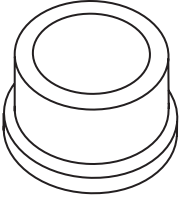
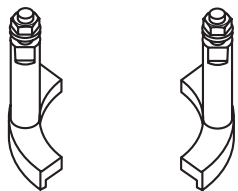
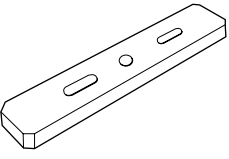
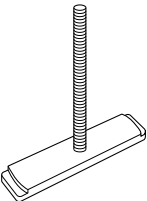
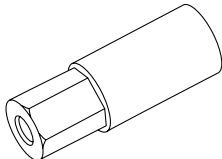
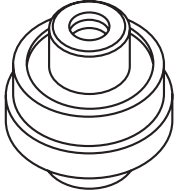

1: Mazda **SST** number
2: Ford **SST** number

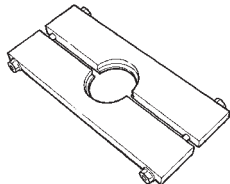
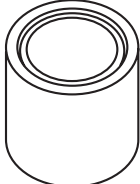
<p>1:49 0107 680A 2:-</p> <p>Engine stand</p> 	<p>1:49 0839 425C 2:-</p> <p>Bearing puller set</p> 	<p>1:49 B019 002 2:-</p> <p>Body</p> 
<p>1:49 B019 025 2:-</p> <p>Preload adopter (component part for 49 B019 0A3)</p> 	<p>1:49 B019 0A4 2:-</p> <p>Locknut wrench set</p> 	<p>1:49 B019 027 2:-</p> <p>Socket (component part for 49 B019 0A4)</p> 
<p>1:49 B019 028 2:-</p> <p>Holder (component part for 49 B019 0A4)</p> 	<p>1:49 B019 029 2:-</p> <p>Plate (component part for 49 B019 0A4)</p> 	<p>1:49 B025 001 2:-</p> <p>Body</p> 
<p>1:49 D034 201 2:-</p> <p>Dust boot installer</p> 	<p>1:49 F011 104 2:-</p> <p>Installer</p> 	<p>1:49 F027 005 2:-</p> <p>Attachment for 62 bearing (component part for 49 F027 0A1)</p> 
<p>1:49 F027 009 2:-</p> <p>Attachment for 68 and 77 bearing</p> 	<p>1:49 G019 025 2:-</p> <p>Body B</p> 	<p>1:49 G019 026 2:-</p> <p>Plate</p> 
<p>1:49 G019 027 2:-</p> <p>Attachment A</p> 	<p>1:49 G019 029 2:-</p> <p>Nut</p> 	<p>1:49 G026 102 2:-</p> <p>Bearing replacer</p> 

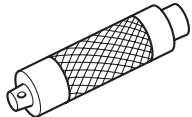
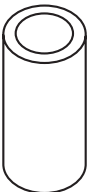
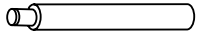
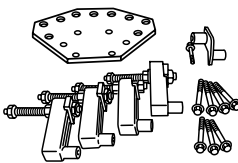
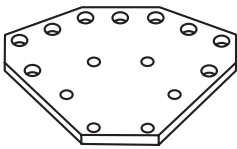
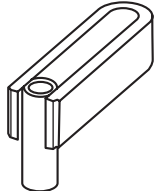
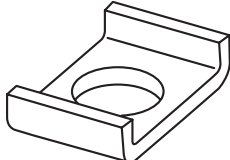
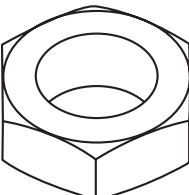
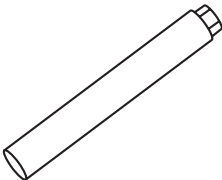
SERVICE TOOLS

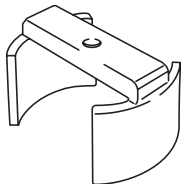
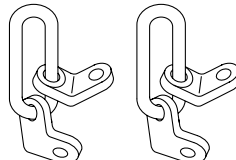
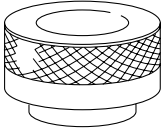
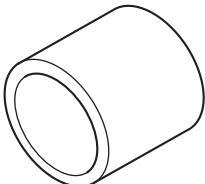
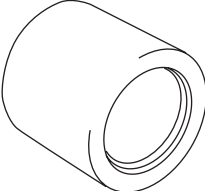
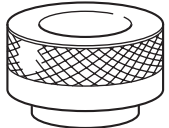
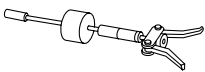
<p>1:49 G027 002 2:-</p> <p>Removing plate</p> 	<p>1:49 G028 201 2:-</p> <p>Support block</p> 	<p>1:49 G030 728 2:-</p> <p>Attachment B</p> 
<p>1:49 G030 797 2:-</p> <p>Handle</p> 	<p>1:49 G032 308 2:-</p> <p>Oil seal installer</p> 	<p>1:49 G033 102 2:-</p> <p>Handle</p> 
<p>1:49 L010 1A0 2:-</p> <p>Engine hanger set</p> 	<p>1:49 L010 101 2:-</p> <p>Plate (component part for 49 L010 1A0)</p> 	<p>1:49 L010 102 2:-</p> <p>Arm (component part for 49 L010 1A0)</p> 
<p>1:49 L010 103 2:-</p> <p>Hook (component part for 49 L010 1A0)</p> 	<p>1:49 L010 104 2:-</p> <p>Nut (component part for 49 L010 1A0)</p> 	<p>1:49 L010 105 2:-</p> <p>Bolt (component part for 49 L010 1A0)</p> 
<p>1:49 M005 796 2:-</p> <p>Body</p> 	<p>1:49 T019 003 2:-</p> <p>Body</p> 	<p>1:49 UN30 3050 2:303-050</p> <p>Engine lifting bracket</p> 
<p>1:49 UB71 525 2:-</p> <p>Bearing installer</p> 	<p>1:49 U027 003 2:-</p> <p>Oil seal installer</p> 	<p>1:49 U034 204 2:-</p> <p>Dust boot installer</p> 
<p>1:49 V001 525 2:-</p> <p>Bearing installer</p> 	<p>1:49 W032 2A0 2:-</p> <p>Bearing remover set</p> 	<p>1:49 W033 105 2:-</p> <p>Oil seal installer</p> 